

# Catalogue for Alternative Construction Materials and Technologies

## DESIGN CATALOGUE FOR RECONSTRUCTION OF EARTHQUAKE RESISTANT HOUSES

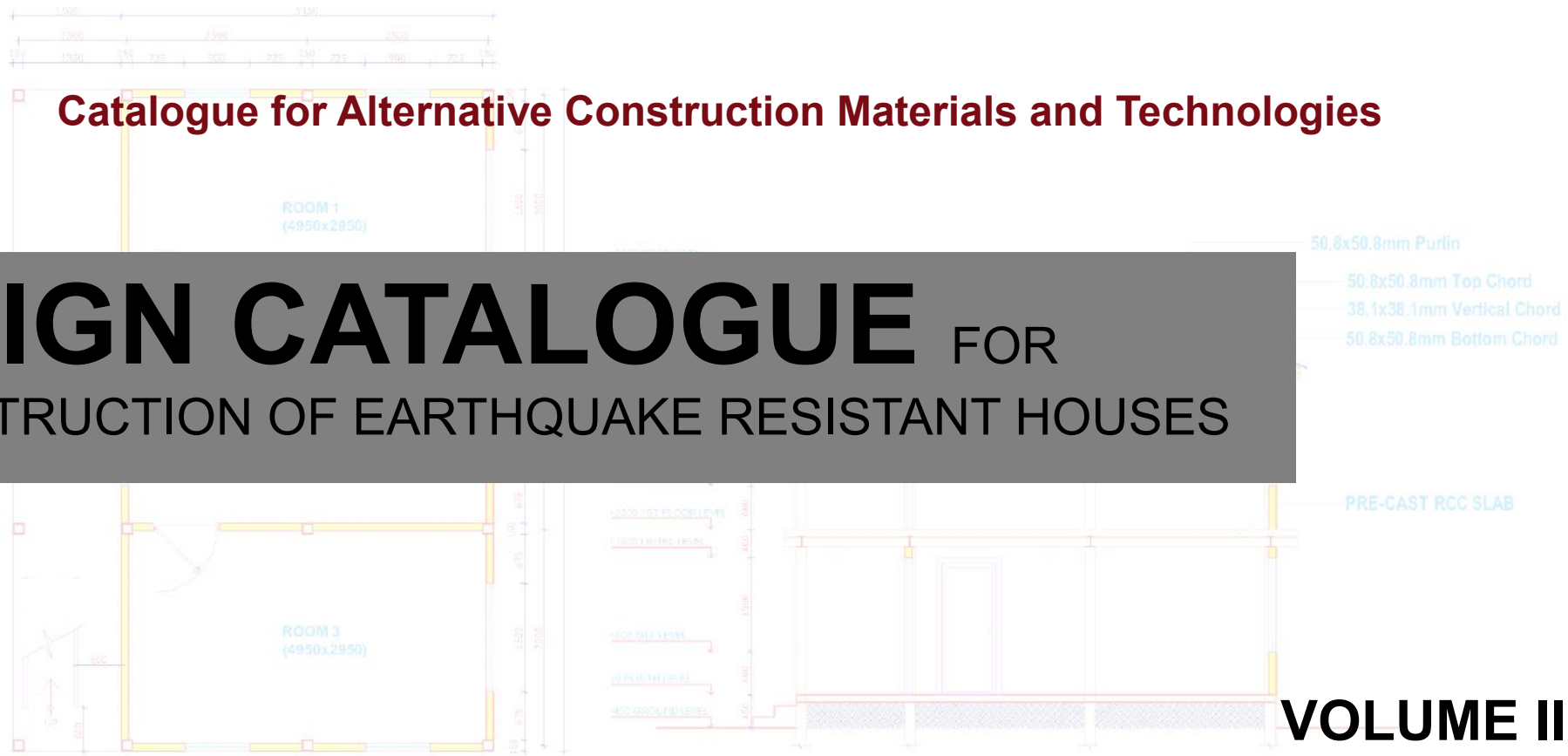

MARCH, 2017 (CHAITRA, 2073)



GOVERNMENT OF NEPAL  
MINISTRY OF URBAN DEVELOPMENT  
DEPARTMENT OF URBAN DEVELOPMENT AND BUILDING CONSTRUCTION  
BABARMAHAL, KATHMANDU

# **DESIGN CATALOGUE FOR RECONSTRUCTION OF EARTHQUAKE RESISTANT HOUSES**

**Approved by Nepal Government, Ministry of Urban Development (Minister Level)  
2073/12/16**

## **VOLUME-II**



**GOVERNMENT OF NEPAL  
MINISTRY OF URBAN DEVELOPMENT  
DEPARTMENT OF URBAN DEVELOPMENT AND BUILDING CONSTRUCTION  
BABARMAHAL, KATHMANDU**

# FOREWORD

It is my immense pleasure that Design Catalogue Volume II comprising of alternative construction materials and technologies is published. The devastating Earthquake of 25<sup>th</sup> April 2015 and its aftershocks not only resulted in massive loss of life and properties but also raised awareness among development practitioners the need to improve our physical infrastructures to make our communities resilient against these kind of disasters. I see this post-earthquake reconstruction as an opportunity to improve our housing construction technology and practice at grass root level.

The objective of this document is to pave way for use of alternate materials and technologies in the reconstruction process. As per the principles set by Post Disaster Needs Assessment (PDNA) for housing and human settlements recovery and reconstruction, the proposed cost efficient, environment friendly and green technologies are expected to be helpful for sustainable reconstruction of both urban and rural houses.

I would like to sincerely thank Mr. Deependra Nath Sharma, respected Secretary of Ministry of Urban Development for his valuable support and suggestion during the process. I am also thankful to Mr. Ravi Shah, former Deputy Director General, Mr. Ram Chandra Dangal, Deputy Director General (Housing Division) and Mr. Raju Neupane, Senior Divisional Engineer and all the staffs of Housing Division for their continuous involvement during the preparation of this document. I also express my thanks to the team of Central Level Project Implementation Unit (CLPIU) for their support in bringing out this publication. My thanks also goes to all the personnel and agencies for their hard work and concerned efforts on preparation of this important document.



---

**Er. Shiva Hari Sharma**

Director General,

Department of Urban Development and Building Construction (DUDBC)



# PREFACE

I would like to congratulate all the personnel and agencies involved in the development of Design Catalogue Volume II for reconstruction of Earthquake Resistant Houses. This publication has been developed by the Department of Urban Development and Building Construction to support urban and rural households in the reconstruction of their houses.

The second volume of Design Catalogue consists of seventeen model designs based on twelve alternative materials and technologies not covered by Nepal National Building Code. A wide variety in terms of materials, technology, cost, size and layout are provided to cater the diverse need of both urban and rural households. The proposed designs are ready to use designs and technical details are provided accordingly.

I again express my sincere thanks to members of Technical Working Group, Task Force, Structural experts, UNDP and all personnel of DUDBC and Central Level Project Implementation Unit (CLPIU) involved directly or indirectly in preparation of this publication.



A handwritten signature in black ink, appearing to read 'R. Dangal', written over a horizontal line.

**Er. Ram Chandra Dangal**

Deputy Director General,

Department of Urban Development and Building Construction (DUDBC)

# BACKGROUND

The devastating earthquake of April 25<sup>th</sup>, 2015 and its aftershocks caused widespread damage to both life and properties. Housing and Human settlement sector was one of the most affected sector. The Government of Nepal figures indicate that around 602,257 houses were fully damaged, 285,099 houses were partially damaged and loss of life was about 9000.

The Post Disaster Needs Assessment (PDNA) report of Government of Nepal, sets out principles for housing and human settlements recovery and reconstruction as follows:

- Encourage the participation of communities by empowering them to take control of reconstruction of their houses and ensuring facilitation of Owner Driven reconstruction
- A comprehensive view of housing reconstruction should indicate holistic habitat development, with basic services and community infrastructure. The principles of Build Back Better (BBB) should translate into a concept of safer settlements.
- Reconstruction should be seen as a vehicle to build long-term community resilience by reducing vulnerabilities and strengthening community capacities to mitigate future disasters through improved construction practices for the majority of building stock in the country.
- Strengthen the local economy through reconstruction and processes that work to the benefit of the poor and marginalised sections who are mostly in the informal sector. Reconstruction should provide an opportunity for the poor to upgrade their living conditions.
- Ensure sustainable and environment-friendly reconstruction processes, taking note of climate change, natural resource management and scientific risk assessments.
- Ensure that rehabilitation is equitable and inclusive.

# INTRODUCTION

DUDBC has prepared second volume of Design Catalogue and named it as “**Catalogue for Reconstruction of Earthquake Resistant Houses Volume II**”. The Catalogue includes architectural design, structural detailing and material estimate. The main objective is to support urban and rural households in reconstruction of their houses.

The model designs of seventeen houses provided in the catalogue are placed under the following twelve technologies:

- Interlocking Brick Masonry
- Confined Hollow Concrete Block Masonry
- Hollow Concrete Block Masonry
- Compressed Stabilized Earth Block Masonry
- Random Rubble Masonry with GI Wire Containment
- Bamboo and Stone Masonry Hybrid Structure
- Rat Trap Bond Masonry
- Earth Bag Masonry
- Light Gauge Steel Structure
- Steel Structure
- Timber Structure
- Debris block Masonry

The designs provided in this catalogue are based on calculations, model test and analytical tests as these technologies are not covered by Nepal National Building Code, 2060. These designs are approved by Ministry of Urban Development. For each design included in the catalogue, the following information is provided:

- 3D view of the design
- Floor plans
- Elevations
- Section
- Structural Details
- Quantity estimate of major materials

Designs included in this catalogue can be selected and used as they are, for reconstruction of urban and rural housing . For designs, other than those included in this catalogue, detailed engineering design and approval from concerned authorities shall be done.

# LIST OF MODELS

S.N.	TECHNOLOGY	MODEL NO.	PAGE NO.
<b>1</b>	<b>INTERLOCKING BRICK MASONRY</b>		
1.1	ONE STOREY	I.B.-1.1	1
1.2	TWO STOREY	I.B.-1.2	8
1.3	ONE STOREY	I.B.-1.3	21
<b>2</b>	<b>CONFINED HOLLOW CONCRETE BLOCK MASONRY</b>		
2.1	TWO STOREY	C.H.C.-2.1	27
<b>3</b>	<b>HOLLOW CONCRETE BLOCK MASONRY</b>		
3.1	TWO STOREY	H.C.B.-3.1	40
<b>4</b>	<b>COMPRESSED STABILIZED EARTH BLOCK MASONRY</b>		
4.1	ONE STOREY	C.S.E.B.-4.1	53
4.2	TWO STOREY	C.S.E.B.-4.2	63
<b>5</b>	<b>RANDOM RUBBLE MASONRY IN MUD MORTAR WITH GI WIRE CONTAINMENT</b>		
5.1	ONE STOREY	R.R.M.-5.1	72
5.2	TWO STOREY	R.R.M. -5.2	79
<b>6</b>	<b>BAMBOO AND STONE MASONRY HYBRID STRUCTURE</b>		
6.1	TWO STOREY	B.S.M.H.-6.1	90
<b>7</b>	<b>RAT TRAP BOND MASONRY</b>		
7.1	ONE STOREY	R.T.-7.1	106
<b>8</b>	<b>EARTH BAG MASONRY</b>		
8.1	ONE STOREY	E.B.-8.1	118
<b>9</b>	<b>LIGHT GAUGE STEEL STRUCTURE</b>		
9.1	ONE STOREY	L.G.S.-9.1	131
9.2	TWO STOREY	L.G.S.-9.2	142
<b>10</b>	<b>STEEL STRUCTURE</b>		
10.1	TWO STOREY	S.S.-10.1	149
<b>11</b>	<b>TIMBER STRUCTURE</b>		
11.1	TWO STOREY	T.S.-11.1	162
<b>12</b>	<b>DEBRIS BLOCK MASONRY</b>		
12.1	ONE STOREY	D.B.-12.1	172

# TABLE OF CONTENT

<b>FOREWORD</b>	<b>I</b>
<b>PREFACE</b>	<b>II</b>
<b>BACKGROUND</b>	<b>III</b>
<b>INTRODUCTION</b>	<b>IV</b>
<b>LIST OF MODEL HOUSES</b>	<b>V</b>
INTERLOCKING BRICK MASONRY	<b>1-26</b>
CONFINED HOLLOW CONCRETE BLOCK MASONRY	<b>27-39</b>
HOLLOW CONCRETE BLOCK MASONRY	<b>40-52</b>
COMPRESSED STABILIZED EARTH BLOCK MASONRY	<b>53-71</b>
RANDOM RUBBLE MASONRY IN MUD MORTAR WITH GI WIRE CONTAINMENT	<b>72-89</b>
BAMBOO AND STONE MASONRY HYBRID STRUCTURE	<b>90-105</b>
RAT TRAP BOND MASONRY	<b>106-117</b>
EARTH BAG MASONRY	<b>118-130</b>
LIGHT GAUGE STEEL STRUCTURE	<b>131-148</b>
STEEL STRUCTURE	<b>149-161</b>
TIMBER STRUCTURE	<b>162-171</b>
DEBRIS BLOCK MASONRY	<b>172-181</b>



# INTERLOCKING BRICK MASONRY

**I.B.-1.1**

**I.B.-1.2**

**I.B.-1.3**

Interlock Brick Technology consists of specially designed unburnt bricks with tongue and groove features that allows bricks to interlock each other in masonry and thereby reduces mortar usage. Construction with interlocking brick is economical, quick and environment friendly. Special design of interlocking bricks allows for vertical reinforcement bars in strategic locations of buildings. Three designs are featured under this category. Model I.B 1.1 and I.B 1.3 are single storied one bedroom units. Load bearing walls are of Interlocking Bricks with corrugated galvanized iron sheet roofing. Model I.B. 1.2 is a two storied 3 bedroom housing units. Interlocking bricks are used for wall and precast joist and pan are used for floors. Both vertical and horizontal reinforcement are used and grouted respectively in different part of building

### **MATERIAL PROPERTIES**

Block Size: 30cm X 15cm X10cm of Full Size  
15cm X 15cm X10cm of Half Size

Min Compressive Strength of Block : 3.5 MPa

Nominal Mix Ratio: 1:1.5:3 (C:S:A)

Min Yield Strength of Reinforcing Steel :415 MPa



*Regular Brick 15 X 30 X 10 cm*



*Half regular Brick 15 X 15 X 10 cm*



*U-shaped Brick 15 X 30 X 10 cm*



*Half U-shaped Brick 15 X 15 X 10 cm*

# **I.B.-1.1**

# **I.B.-1.2**

# **I.B.-1.3**



LEVEL	MATERIALS								
	Stone	Interlocking Bricks	Cement	Sand	Aggregate	Reinforcing Bar	CGI sheet	GI Sheet	Wood
	Cu,m	No.	Bags	Cu.m.	Cu.m.	Kg.	Bundle	Sq.m.	Cu.m.
Up to Plinth Level	8.4	-	40	5.3	3.2	112.1			-
Super Structure	-	4,912.0	17	0.9	1.7	167.3			0.1
Roofing	-	-	-	-	-	-	3.5	6.5	0.9
<b>TOTAL</b>	<b>8.4</b>	<b>4,912</b>	<b>57</b>	<b>6.2</b>	<b>4.9</b>	<b>279.4</b>	<b>3.5</b>	<b>6.5</b>	<b>1.0</b>



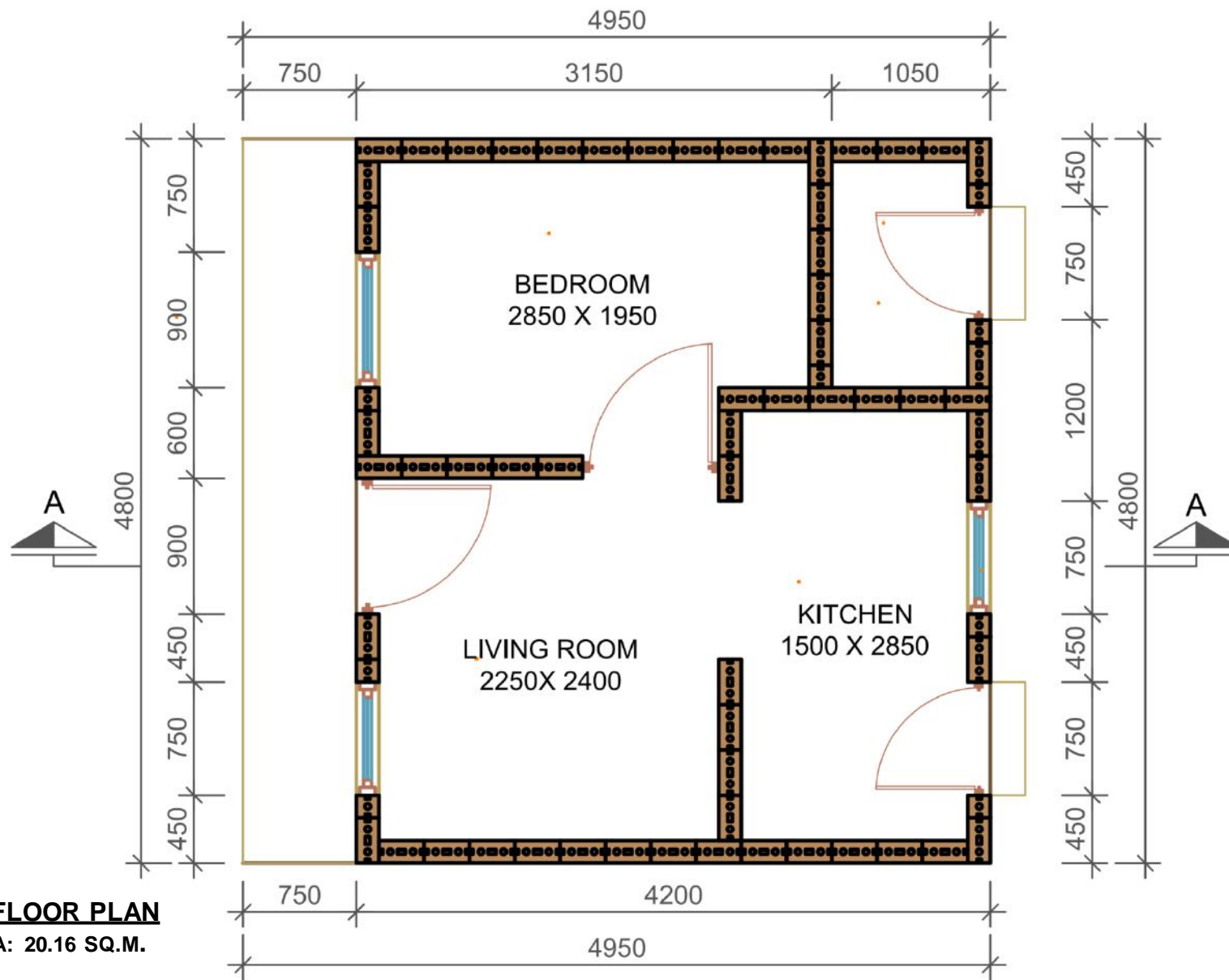

**GROUND FLOOR PLAN**  
FLOOR AREA: 20.16 SQ.M.



MINISTRY OF URBAN DEVELOPMENT  
DEPARTMENT OF URBAN DEVELOPMENT AND  
BUILDING CONSTRUCTION

HOUSING TYPE: I.B.-1.1

DRAWING TITLE: GROUND FLOOR PLAN

SCALE: NONE

DATE:

I.B.-1.1

2/5

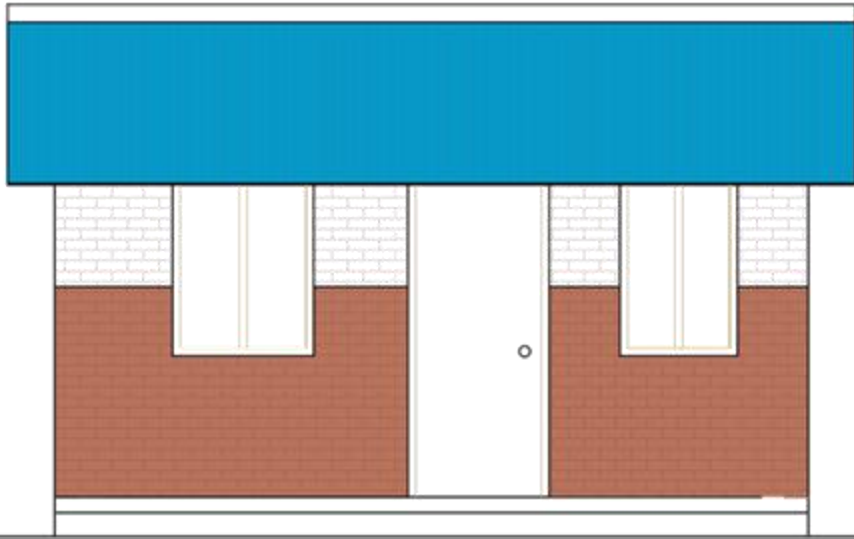

**FRONT ELEVATION**

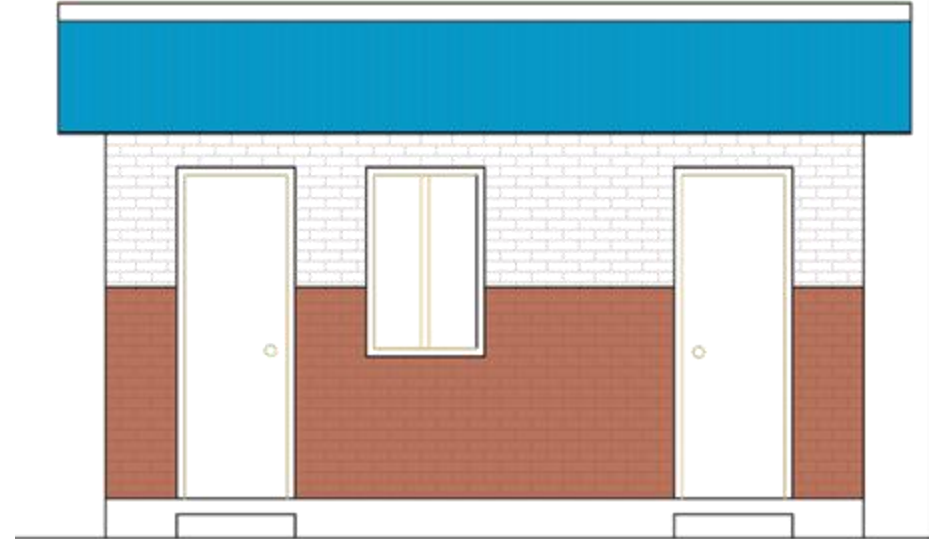

**BACK ELEVATION**

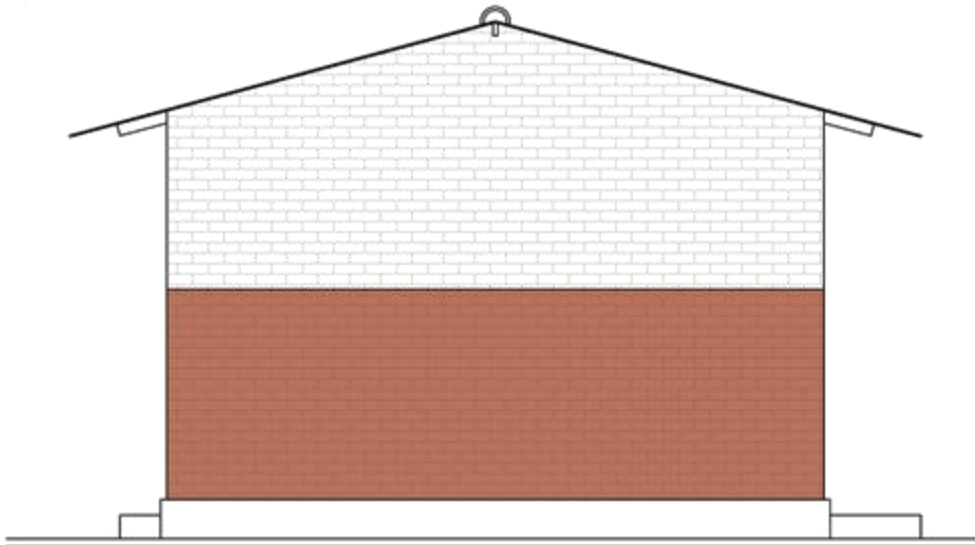

**SIDE ELEVATION**

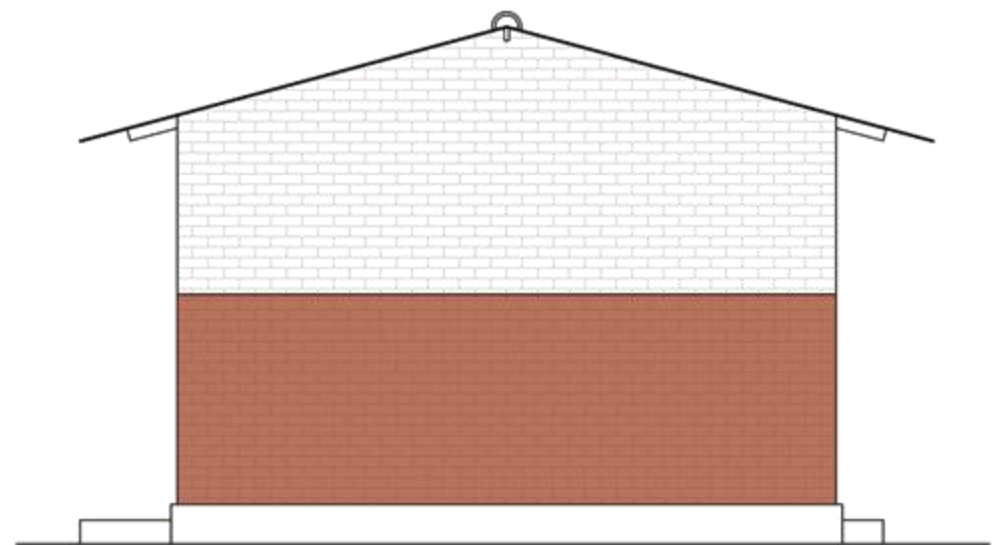

**SIDE ELEVATION**



MINISTRY OF URBAN DEVELOPMENT  
DEPARTMENT OF URBAN DEVELOPMENT AND  
BUILDING CONSTRUCTION

HOUSING TYPE: I.B.-1.1

DRAWING TITLE: ELEVATIONS

SCALE: NONE

DATE:

I.B.-1.1

3/5

# MODEL I.B.-1.1, INTERLOCKING BRICK MASONRY

ONE STOREY

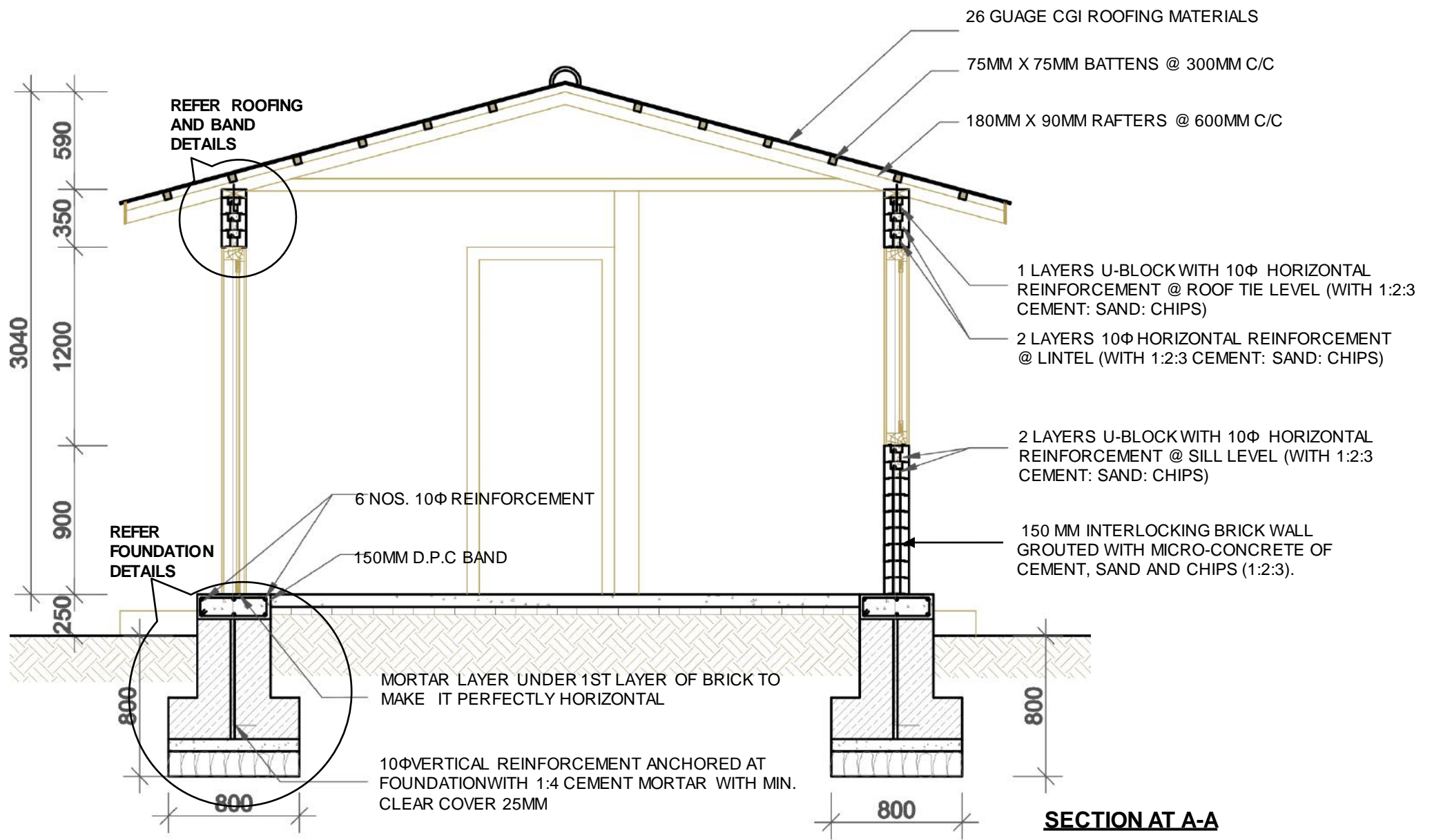

MINISTRY OF URBAN DEVELOPMENT  
DEPARTMENT OF URBAN DEVELOPMENT AND  
BUILDING CONSTRUCTION

HOUSING TYPE: I.B.-1.1

DRAWING TITLE: SECTION

SCALE: NONE

DATE:

I.B.-1.1

4/5

**TECHNICAL REQUIREMENTS**

<b>Structure System</b>	Reinforced Stabilized Interlocking Brick Masonry Structure with horizontal and vertical reinforcing bars in strategic locations.
<b>Foundation</b>	Strip Foundation of Stone Masonry in 1:6 cement sand mortar. Foundation size shall be of width 800mm and depth 800 mm (refer drawing).
<b>Plinth Band</b>	R.C.C (1:1.5:3) band of size 450mm x 150 mm. 6 nos. of 10 mm Ø reinforcement with 8 mm Ø stirrups at 150 mm C/C.
<b>Wall</b>	Load bearing walls of Interlocking bricks. Interlocking bricks shall be made of cement and soil mixed in 1:8 ratio. Two types of Interlocking blocks; normal and U shaped shall be used in full size (300 x 150x 100 mm) and half size (150 x 150 x 100 mm). These blocks shall be air cured for 1 day and water cured for 21 days. Minimum Compressive strength of the block shall be 3.5 Mpa. 12 mm Ø vertical bars shall be provided at corners and joints and grouted with Micro concrete 1:2:3 (Cement, Sand & Chips) ratio. Horizontal reinforcement requirement is stated in sill and lintel details below.
<b>Sill Band</b>	2 layers of special U shaped Interlocking bricks shall be used in Sill level. In the groove of U shaped Bricks, 12 mm Ø reinforcements shall be provided in each layer and grouted with Micro concrete 1:2:3 (Cement, Sand and Chips) ratio.
<b>Lintel Band:</b>	2 layers of special U shaped Interlocking bricks shall be used in Lintel level. In the groove of U shaped Bricks, 12 mm Ø reinforcements shall be provided in each layer and grouted with Micro concrete 1:2:3 (Cement, Sand and Chips) ratio.
<b>Roof:</b>	Lightweight roof of corrugated Iron sheet over wooden truss. All joints in the truss shall be properly connected as shown in the drawing.





LEVEL	MATERIALS								
	Stone	Interlocking Bricks	Cement	Sand	Aggregate	Reinforcing Bar	CGI sheet	GI Sheet	Wood
	Cu.m	No.	Bags	Cu.m.	Cu.m.	Kg.	Bundle	Sq.m.	Cu.m.
Up to Plinth Level	18.1	-	80.5	10.9	6.1	177.2			-
Super Structure	-	6,447.0	57.5	3.0	6.1	493.9			1.3
Roofing	-	-	-	-	-	-	4.2	8.7	1.5
<b>TOTAL</b>	<b>18.1</b>	<b>6,447.0</b>	<b>138</b>	<b>13.9</b>	<b>12.2</b>	<b>671.1</b>	<b>4.2</b>	<b>8.7</b>	<b>2.8</b>



MINISTRY OF URBAN DEVELOPMENT  
DEPARTMENT OF URBAN DEVELOPMENT AND  
BUILDING CONSTRUCTION

HOUSING TYPE: I.B.-1.2

DRAWING TITLE: ESTIMATE AND 3D VIEW

SCALE: NONE

DATE:

I.B.-1.2

1/5



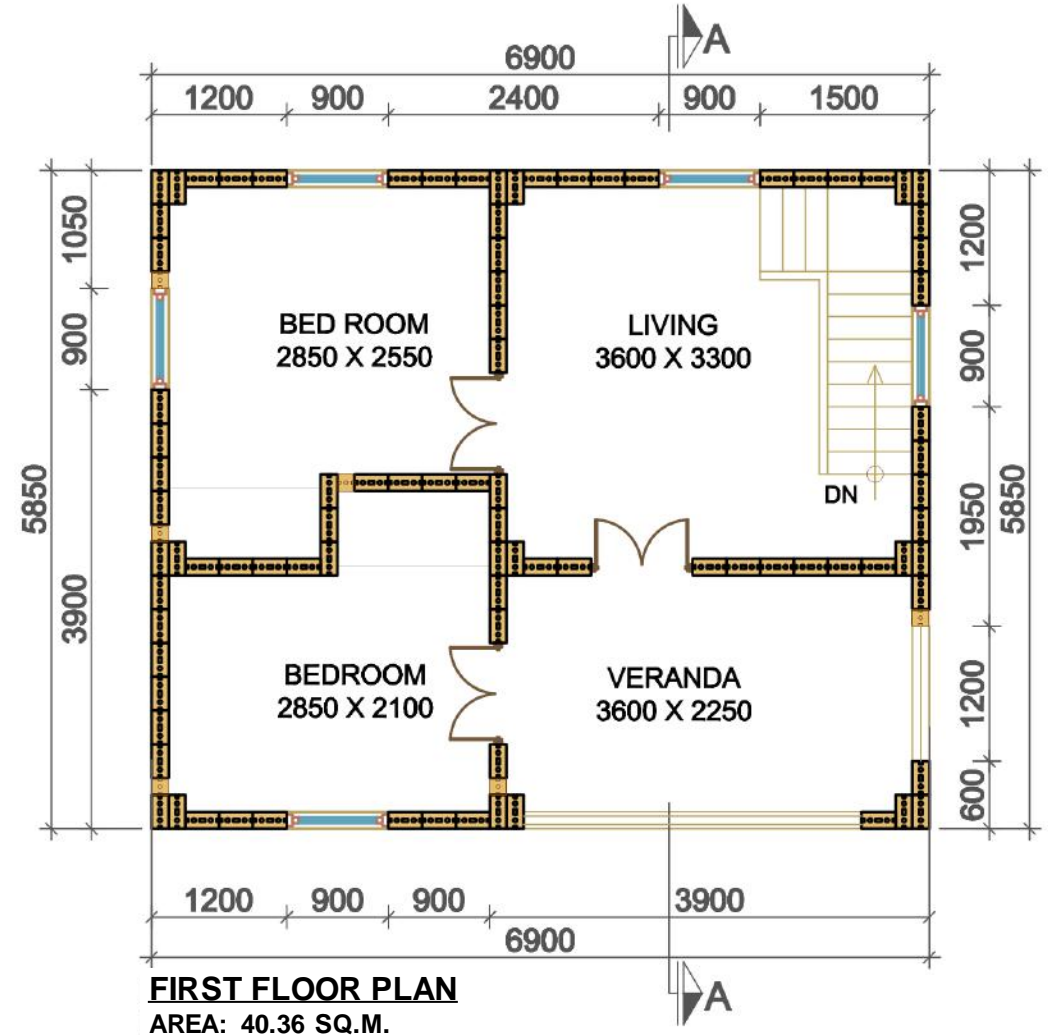
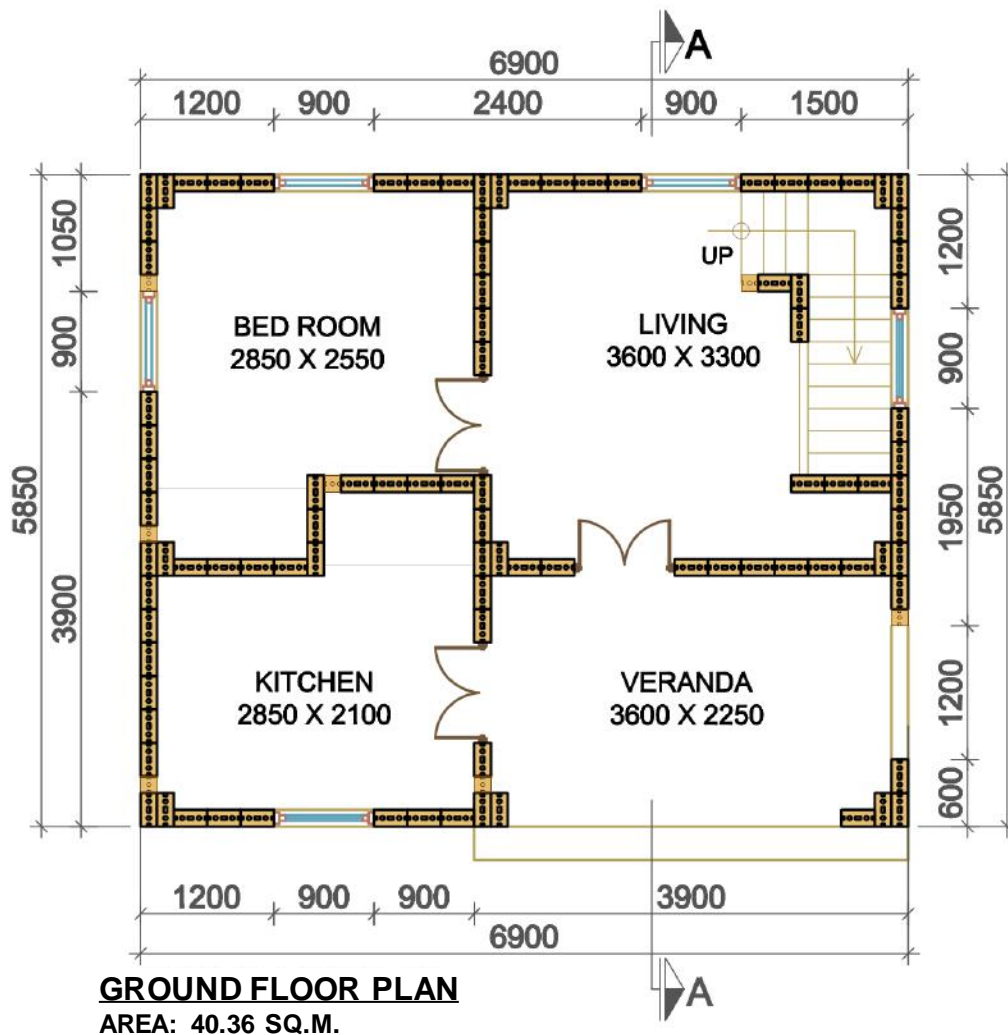



**SIDE ELEVATION**



**FRONT ELEVATION**



**SIDE ELEVATION**



**BACK ELEVATION**



MINISTRY OF URBAN DEVELOPMENT  
DEPARTMENT OF URBAN DEVELOPMENT AND  
BUILDING CONSTRUCTION

HOUSING TYPE: I.B.-1.2

DRAWING TITLE: ELEVATIONS

SCALE: NONE

DATE:

I.B.-1.2

3/5

# MODEL I.B.-1.2, INTERLOCKING BRICK MASONRY

TWO STOREY

26 GAUGE CGI ROOFING MATERIALS  
75MM X 75MM BATTENS @ 300MM C/C  
180MM X 90MM RAFTERS @ 600MM C/C

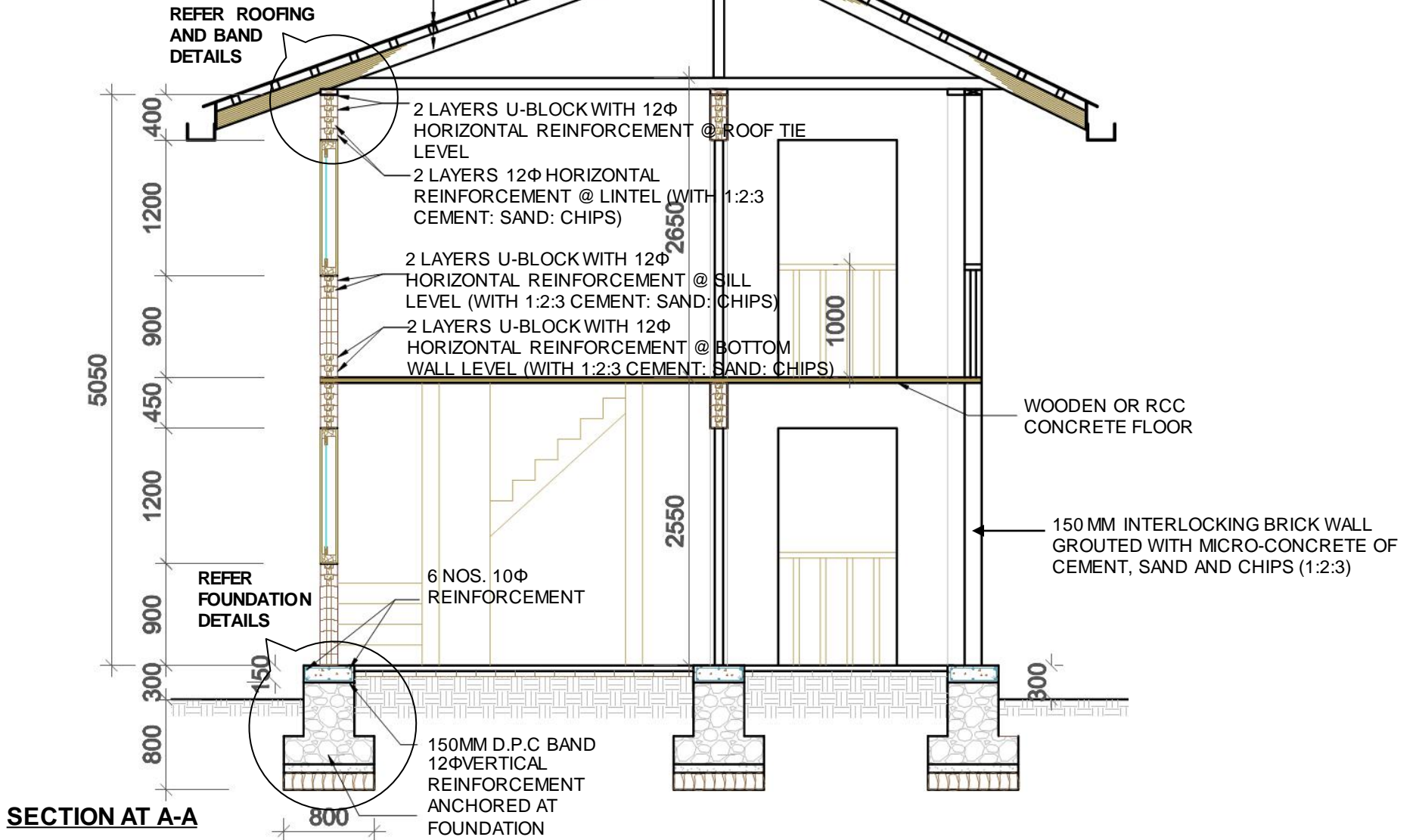

MINISTRY OF URBAN DEVELOPMENT  
DEPARTMENT OF URBAN DEVELOPMENT AND  
BUILDING CONSTRUCTION

HOUSING TYPE: I.B.-1.2

DRAWING TITLE: SECTION

SCALE: NONE

DATE:

I.B.-1.2

4/5

**TECHNICAL REQUIREMENTS**

<b>Structure System</b>	Reinforced Stabilized Interlocking Brick Masonry Structure with horizontal and vertical reinforcing bars in strategic locations.
<b>Foundation</b>	Strip Foundation of Stone/Brick Masonry in 1:6 cement sand mortar. Foundation size shall be width 800 mm and depth 800 mm (refer drawing).
<b>Plinth Band</b>	R.C.C (1:1.5:3) band of size 450mm x 150 mm. 6 nos. of 10 mm Ø reinforcement with 8 mm Ø stirrups at 150 mm C/C.
<b>Wall</b>	Load bearing walls of Interlocking bricks. Interlocking bricks shall be of cement and soil mixed in 1:8 ratio. Two types of Interlocking blocks; normal and U shaped shall be used in full size (300 x 150x 100 mm) and half size (150 x 150 x 100 mm). These blocks shall be air cured for 1 day and water cured for 21 days. Minimum Compressive strength of the block shall be 3.5 Mpa. 12 mm Ø vertical bars shall be provided at corners and joints and grouted with Micro concrete 1:2:3 (Cement, Sand & Chips) ratio. Horizontal reinforcement requirement is stated in sill and lintel details below.
<b>Sill Band</b>	2 layers of special U shaped Interlocking bricks shall be used in Sill level. In the groove of U shaped Bricks, 12 mm Ø reinforcements shall be provided in each layer and grouted with Micro concrete 1:2:3 (Cement, sand and chips) ratio.
<b>Lintel Band:</b>	2 layers of special U shaped Interlocking bricks shall be used in Lintel level. In the groove of U shaped Bricks, 12 mm Ø reinforcements shall be provided in each layer and grouted with Micro concrete 1:2:3 (Cement, sand and chips) ratio.
<b>Floor:</b>	50 mm thick cast in Situ Micro concrete over precast pans and precast concrete joists of 50mm x 200 mm.
<b>Roof:</b>	Lightweight roof of corrugated iron sheet over wooden truss. All joints in the truss shall be properly connected as shown in the drawing.



# MODEL I.B.-1.1 AND I.B.-1.2 , INTERLOCKING BRICK MASONRY

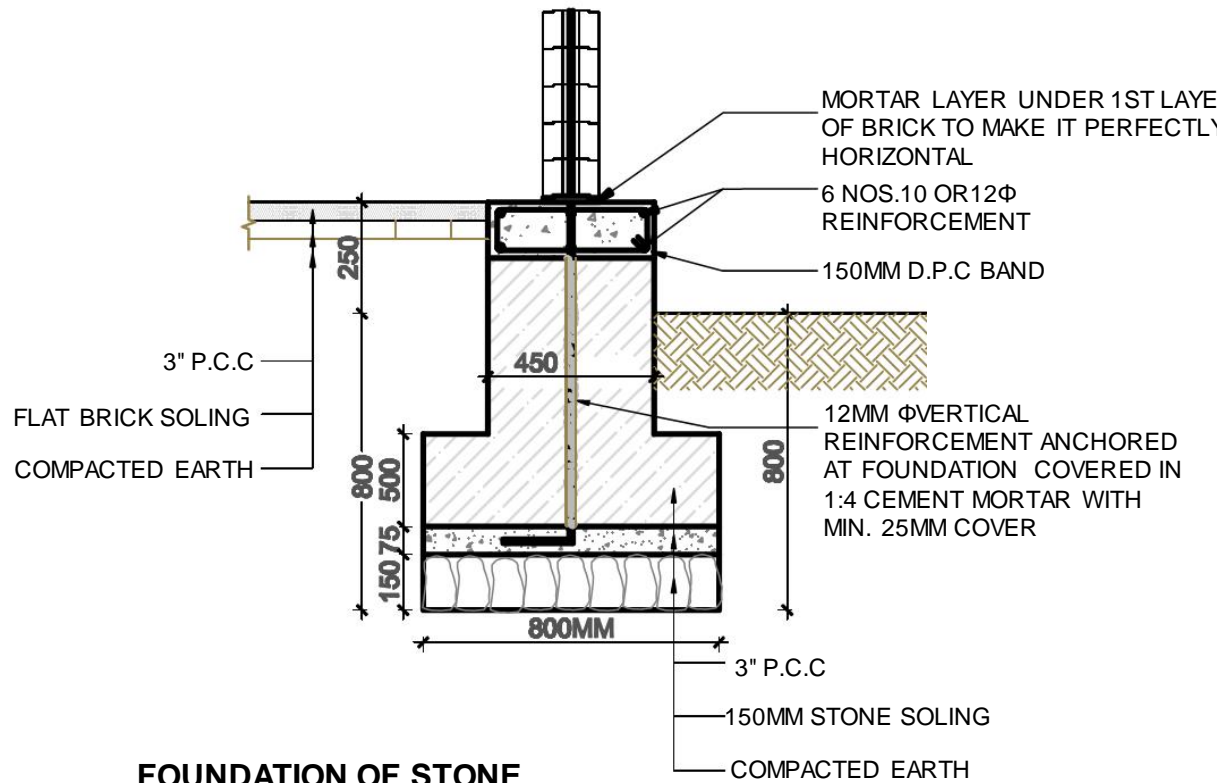

**FOUNDATION OF STONE MASONRY IN CEMENT MORTAR**

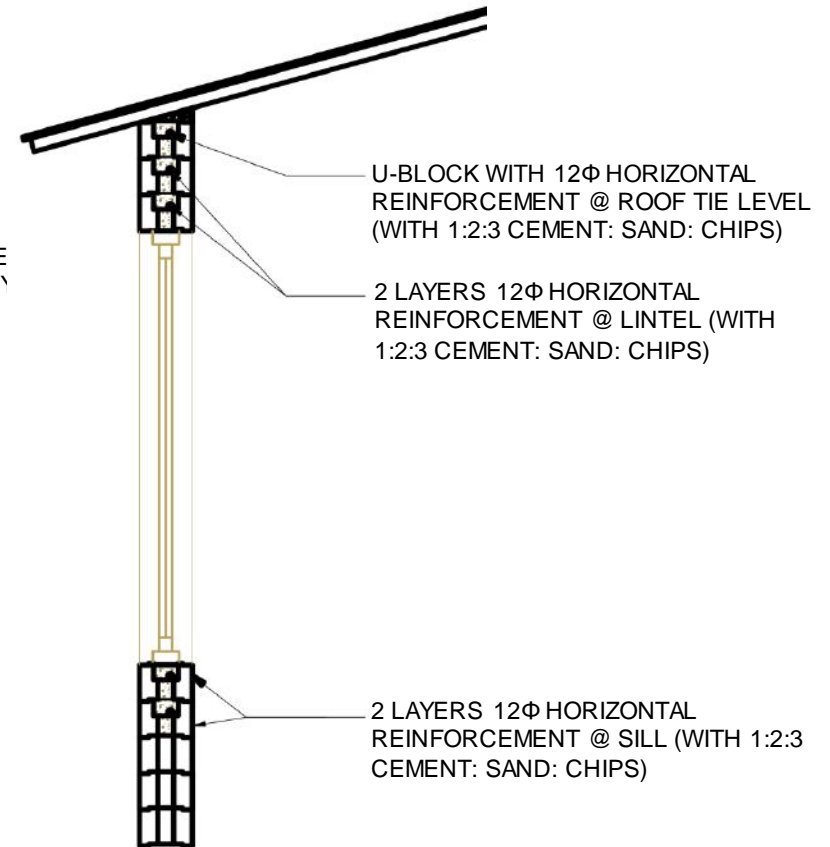

**ROOF, LINTEL AND SILL LEVEL**



MINISTRY OF URBAN DEVELOPMENT  
DEPARTMENT OF URBAN DEVELOPMENT AND  
BUILDING CONSTRUCTION

HOUSING TYPE: I.B.1.1 AND 1.B. 1.2

DRAWING TITLE:STRUCTURAL DETAILS

SCALE: NONE





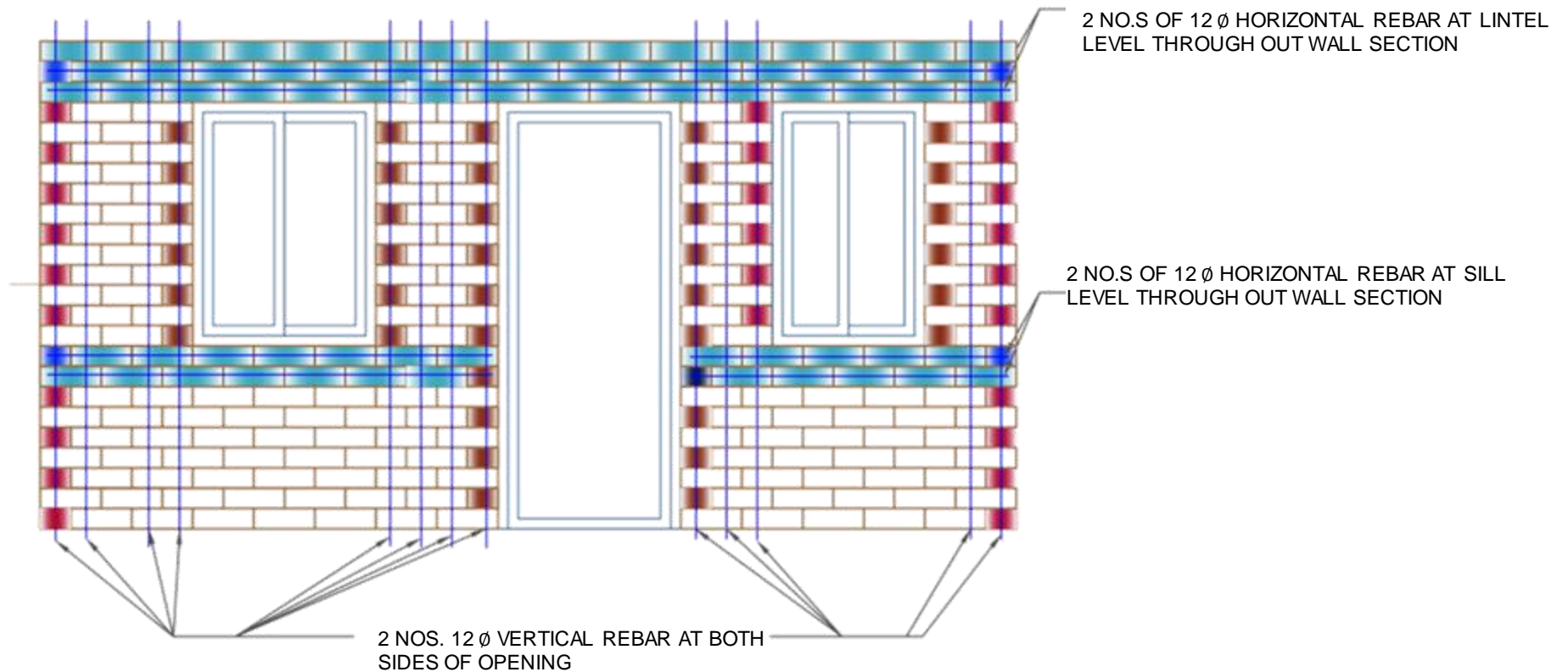

DATE:

I.B.-1.1/1.2

1/8

# MODEL I.B.-1.1 AND I.B.-1.2 , INTERLOCKING BRICK MASONRY



-  REGULAR FULL BRICK
-  REGULAR HALF BRICK
-  LATERAL FULL LOCK BRICK
-  U FULL BRICK
-  U HALF BRICK
-  LATERAL U FULL LOCK BRICK

**TYPICAL ELEVATION (REBAR DETAIL IN WALL)**



MINISTRY OF URBAN DEVELOPMENT  
DEPARTMENT OF URBAN DEVELOPMENT AND  
BUILDING CONSTRUCTION

HOUSING TYPE: I.B.1.1 AND 1.B. 1.2

DRAWING TITLE: STRUCTURAL DETAILS

SCALE: NONE

DATE:

I.B.-1.1/1.2

2/8

# MODEL I.B.-1.1, INTERLOCKING BRICK MASONRY

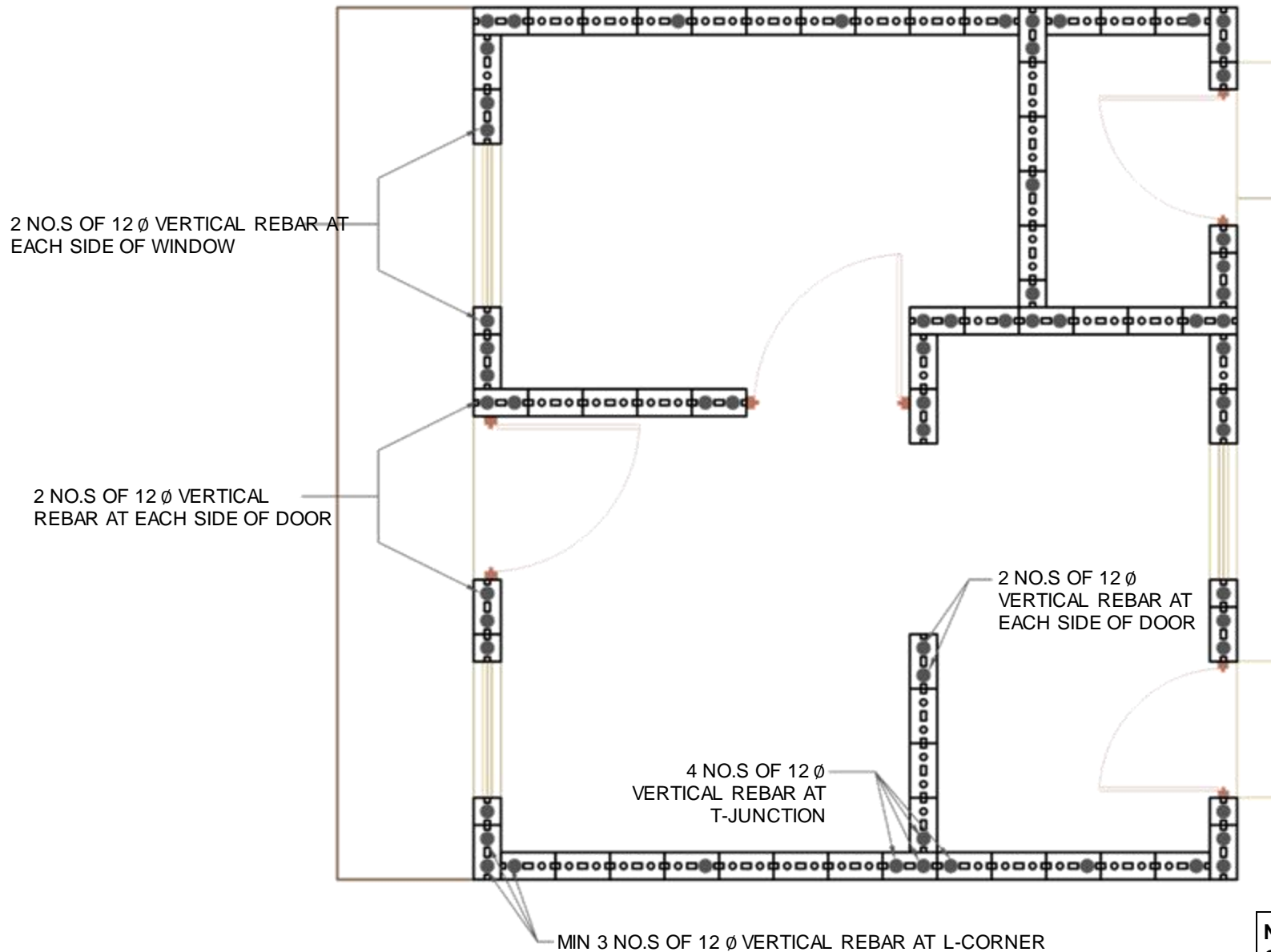

**FRAMING PLAN (REBAR DETAIL)**



MINISTRY OF URBAN DEVELOPMENT  
DEPARTMENT OF URBAN DEVELOPMENT AND  
BUILDING CONSTRUCTION

HOUSING TYPE: I.B.1.1

DRAWING TITLE: STRUCTURAL DETAILS

SCALE: NONE

DATE:

I.B.-1.1

3/8

# MODEL I.B.-1.1 AND I.B.-1.2 , INTERLOCKING BRICK MASONRY

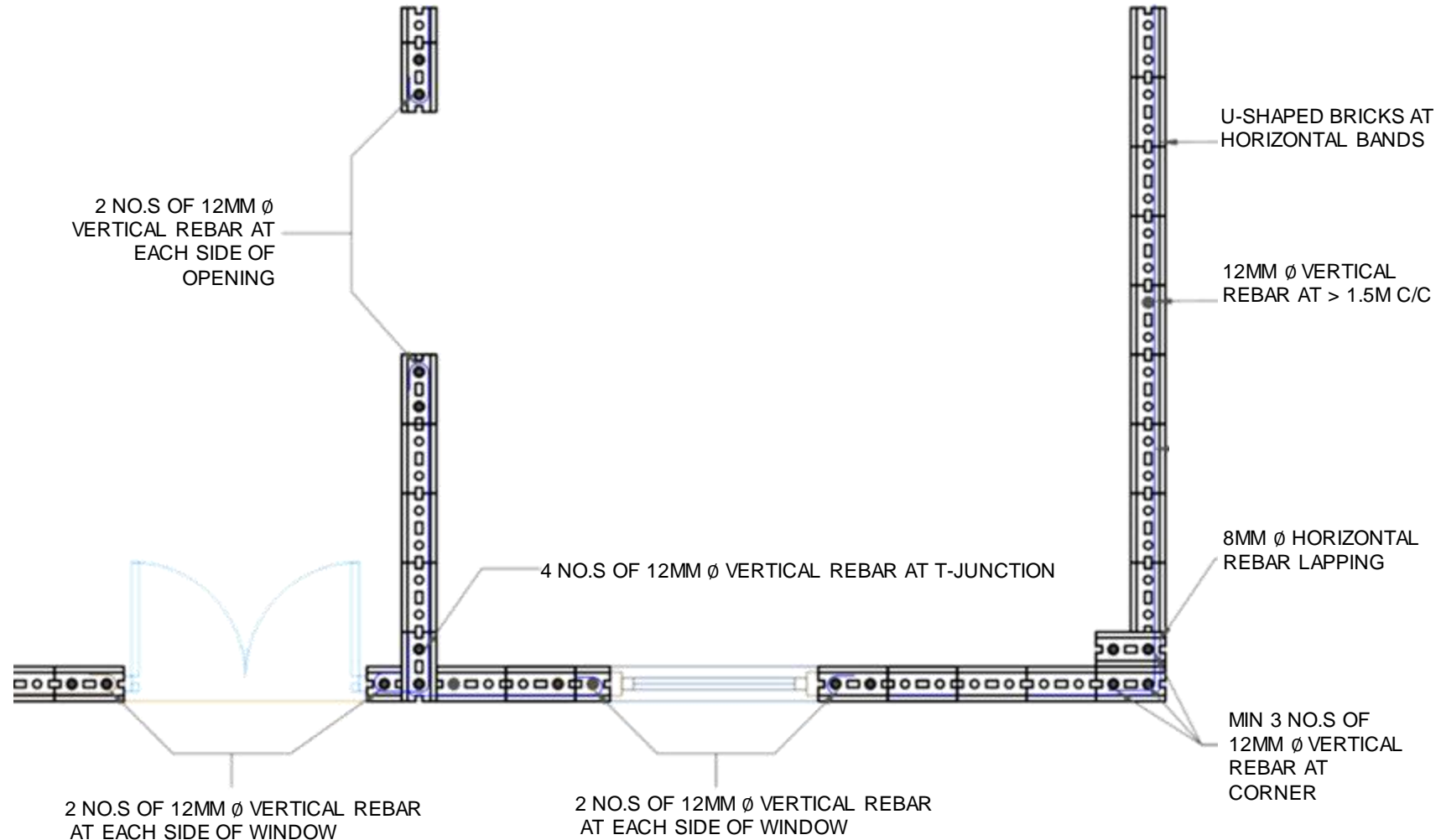

**REBAR DETAIL PLAN AT PLINTH, ROOF, SILL & LINTEL BANDS**

**NOTE:**  
GROUTING FOR THE HOLE IS DONE WITH MORTAR



MINISTRY OF URBAN DEVELOPMENT  
DEPARTMENT OF URBAN DEVELOPMENT AND  
BUILDING CONSTRUCTION

HOUSING TYPE: I.B.1.1 AND I.B. 1.2

DRAWING TITLE: STRUCTURAL DETAILS

SCALE: NONE

DATE:

I.B.-1.1/1.2

4/8



# MODEL I.B.-1.1 AND I.B.-1.2 , INTERLOCKING BRICK MASONRY

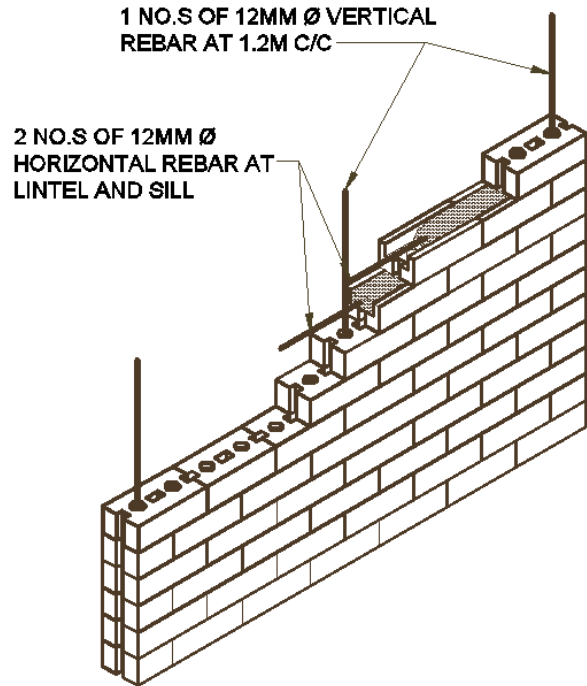

TYPICAL DETAIL OF WALL

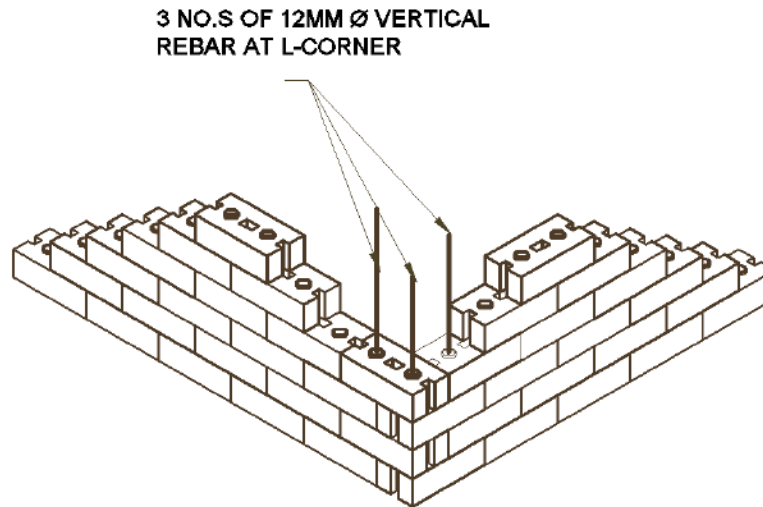

DETAIL A  
(TYPICAL DETAIL OF L-CORNER)

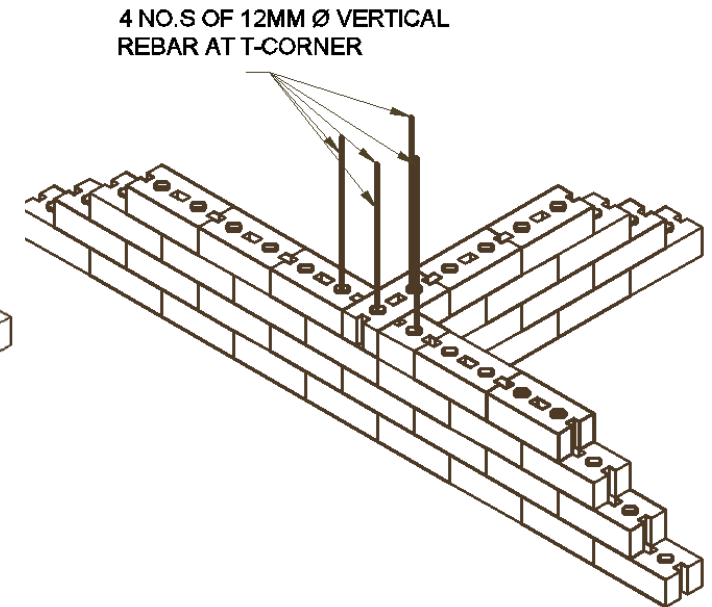

DETAIL B  
(TYPICAL DETAIL OF T-CORNER)



MINISTRY OF URBAN DEVELOPMENT  
DEPARTMENT OF URBAN DEVELOPMENT AND  
BUILDING CONSTRUCTION

HOUSING TYPE: I.B.1.1 AND 1.B. 1.2

DRAWING TITLE: STRUCTURAL DETAILS

SCALE: NONE

DATE:

I.B.-1.1/1.2

5/8

# MODEL I.B.-1.1 AND I.B.-1.2 , INTERLOCKING BRICK MASONRY

2 NO.S OF 12MM  $\emptyset$  VERTICAL REBAR  
AT EACH SIDE OF WINDOW

2 NO.S OF 12MM  $\emptyset$   
HORIZONTAL REBAR AT  
LINTEL LVL

2 NO.S OF 12MM  $\emptyset$   
HORIZONTAL REBAR AT SILL  
LVL

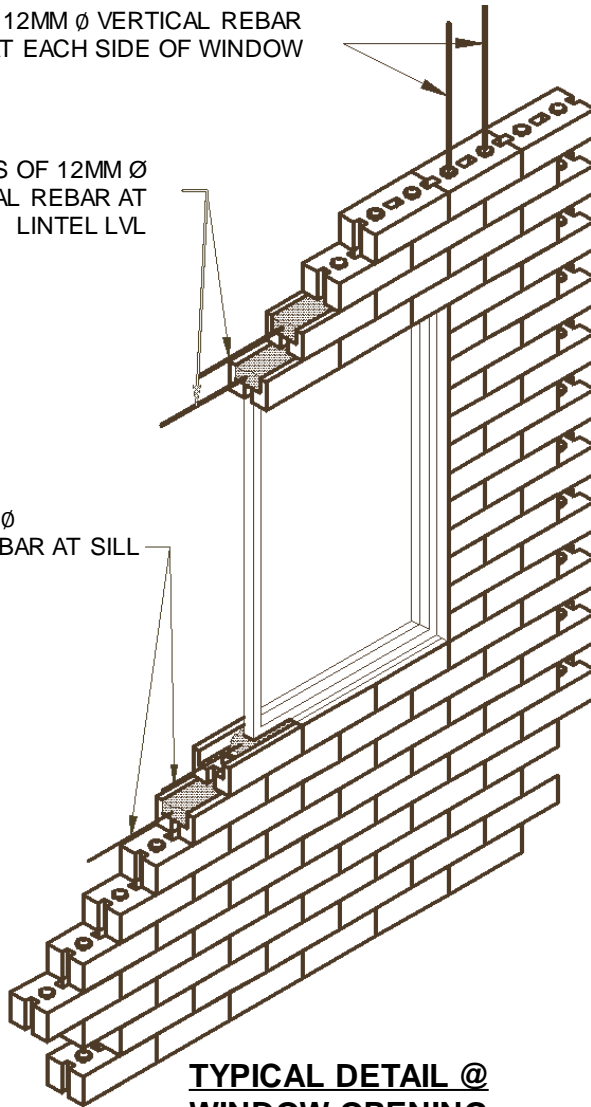

**TYPICAL DETAIL @  
WINDOW OPENING**

2 NO.S OF 12MM  $\emptyset$  VERTICAL REBAR  
AT EACH SIDE OF DOOR

2 NO.S OF 12MM  $\emptyset$   
HORIZONTAL REBAR AT  
LINTEL LVL

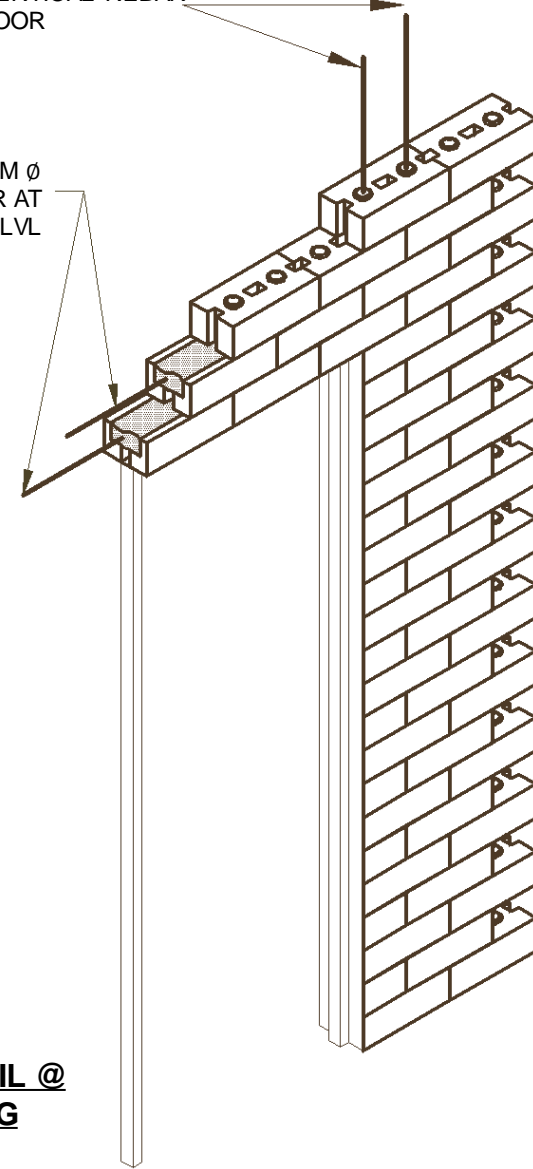

**TYPICAL DETAIL @  
DOOR OPENING**



MINISTRY OF URBAN DEVELOPMENT  
DEPARTMENT OF URBAN DEVELOPMENT AND  
BUILDING CONSTRUCTION

HOUSING TYPE: I.B.1.1 AND 1.B. 1.2

DRAWING TITLE: STRUCTURAL DETAILS

SCALE: NONE

DATE:

I.B.-1.1/1.2

6/8

# MODEL I.B.-1.1 AND I.B.-1.3 , INTERLOCKING BRICK MASONRY

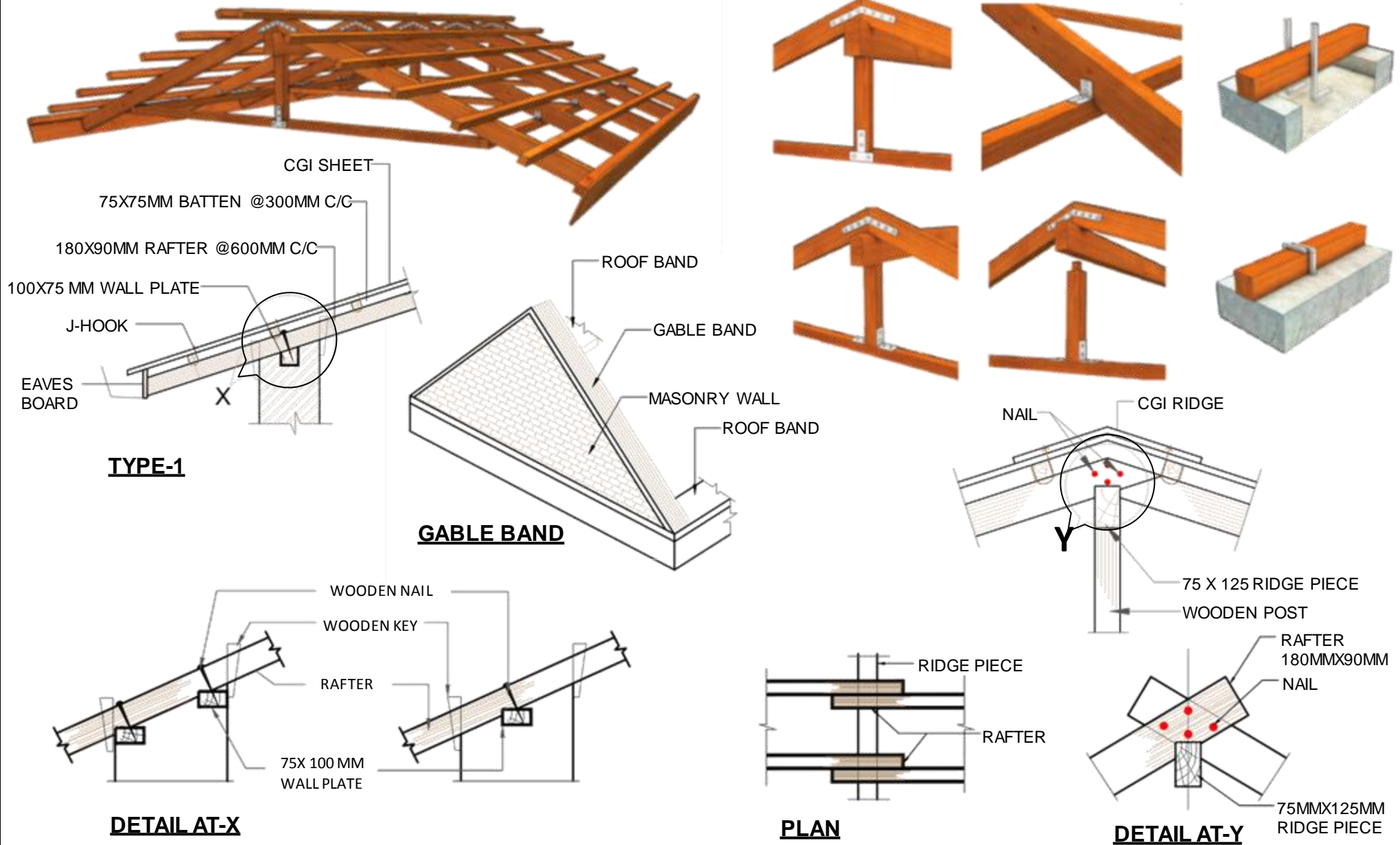

 MINISTRY OF URBAN DEVELOPMENT DEPARTMENT OF URBAN DEVELOPMENT AND BUILDING CONSTRUCTION	HOUSING TYPE: I.B.1.1 AND 1.B. 1.2	SCALE: NONE	I.B.-1.1/1.2
	DRAWING TITLE: ROOF DETAILS	DATE:	

# MODEL I.B.-1.3 , INTERLOCKING BRICK MASONRY

25mm x 25mm steel square tube  
 200mm x 50mm joists @ 600mm c/c  
 600mm x 600mm pans of 10mm thickness in between joists (micro concrete formwork)



**INTERIOR VIEW OF THE FINISHED JOIST AND PAN CAST IN SITU**

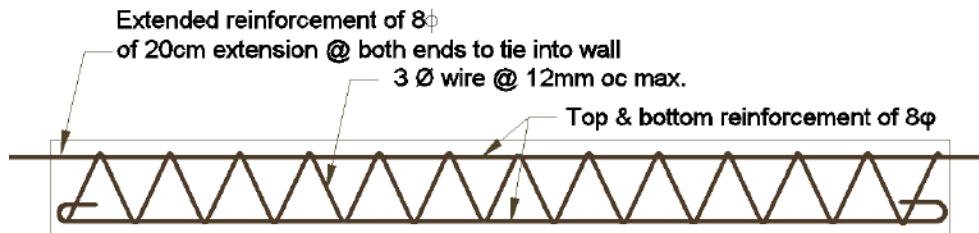
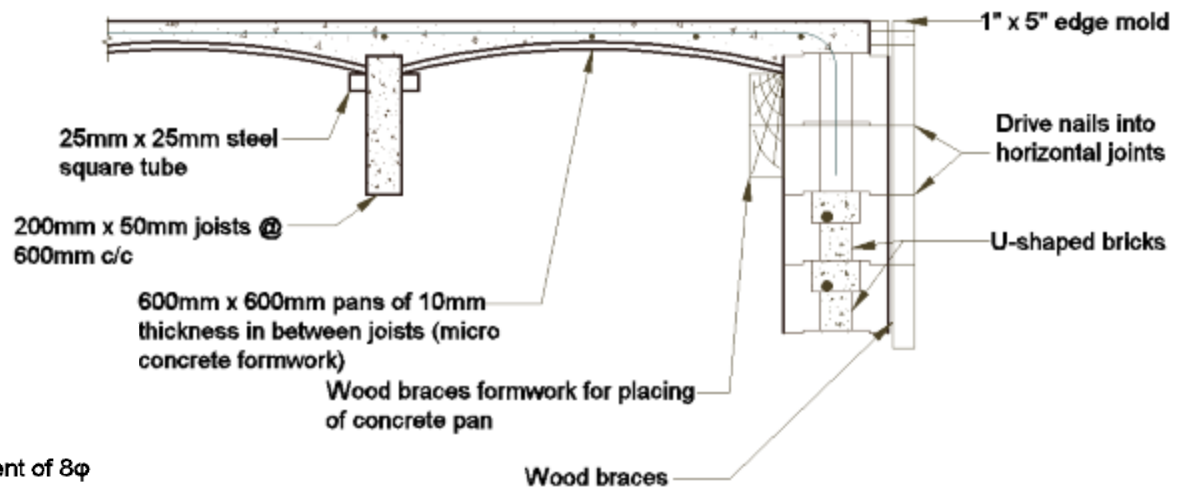
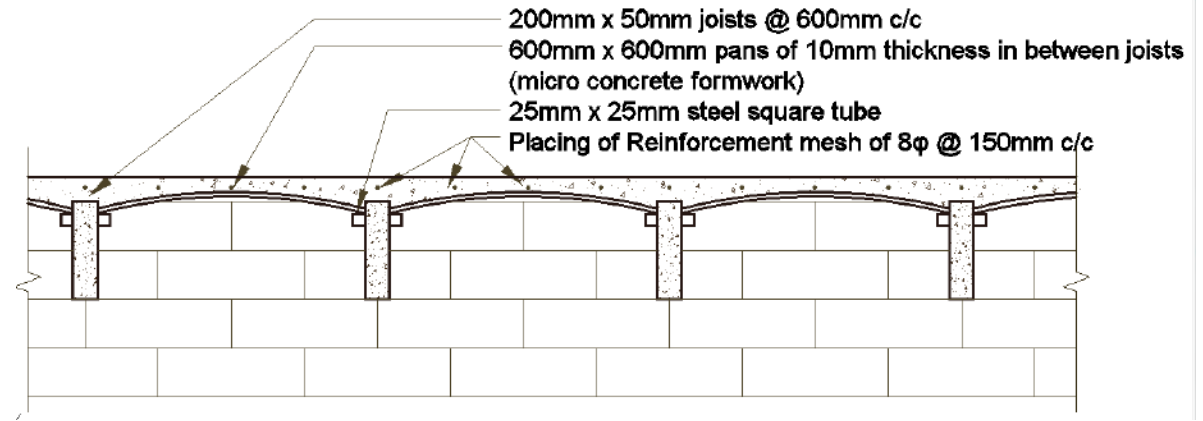

**REINFORCEMENT DETAILS IN CONCRETE JOISTS SPAN UPTO 5M**



MINISTRY OF URBAN DEVELOPMENT  
 DEPARTMENT OF URBAN DEVELOPMENT AND  
 BUILDING CONSTRUCTION

HOUSING TYPE: 1.B. 1.2

DRAWING TITLE: STRUCTURAL DETAILS

SCALE: NONE

DATE:

I.B.-1.3

8/8



LEVEL	MATERIALS								
	Stone	Interlocking Bricks	Cement	Sand	Aggregate	Reinforcing Bar	Clay Tile	Clay Tile Ridge	Wood
	No.	No.	Bags	Cu.m.	Cu.m.	Kg.	Nos	Sq.m.	Cu.m.
Up to Plinth Level	33.5	2,406.0	129	18.3	7.7	832.5			-
Super Structure	-	3,350.0	14	0.9	1.3	188.8			0.3
Roofing	-	-	-	-	-	-	1580	282.0	2.8
<b>TOTAL</b>	<b>33.5</b>	<b>5,756.0</b>	<b>143</b>	<b>19.2</b>	<b>9.0</b>	<b>1,021.3</b>	<b>1580</b>	<b>282.0</b>	<b>3.1</b>



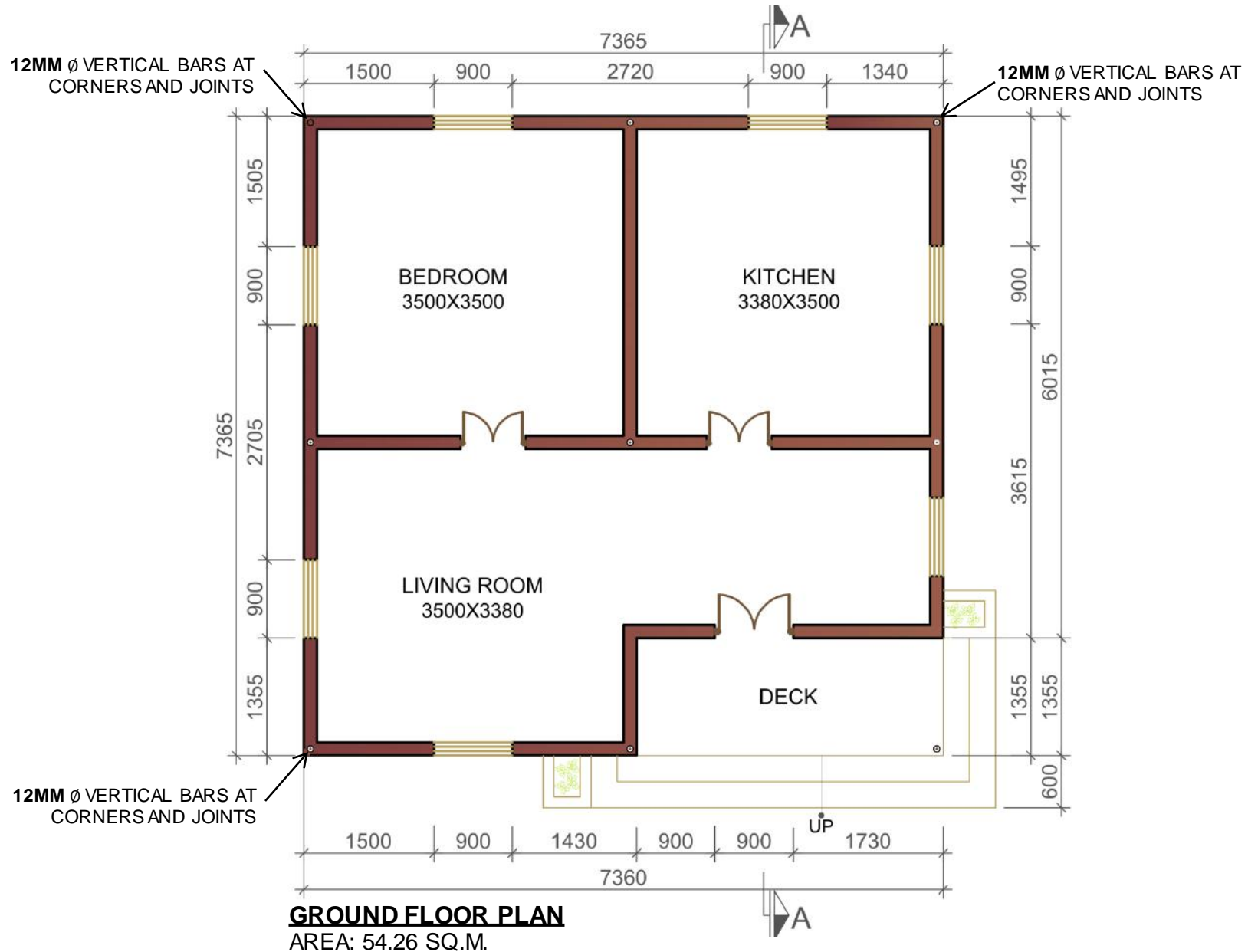

MINISTRY OF URBAN DEVELOPMENT  
DEPARTMENT OF URBAN DEVELOPMENT AND  
BUILDING CONSTRUCTION

HOUSING TYPE: I.B.-1.3

DRAWING TITLE: FLOOR PLAN

SCALE: NONE

DATE:

I.B.-1.3

2/6



**FRONT ELEVATION**

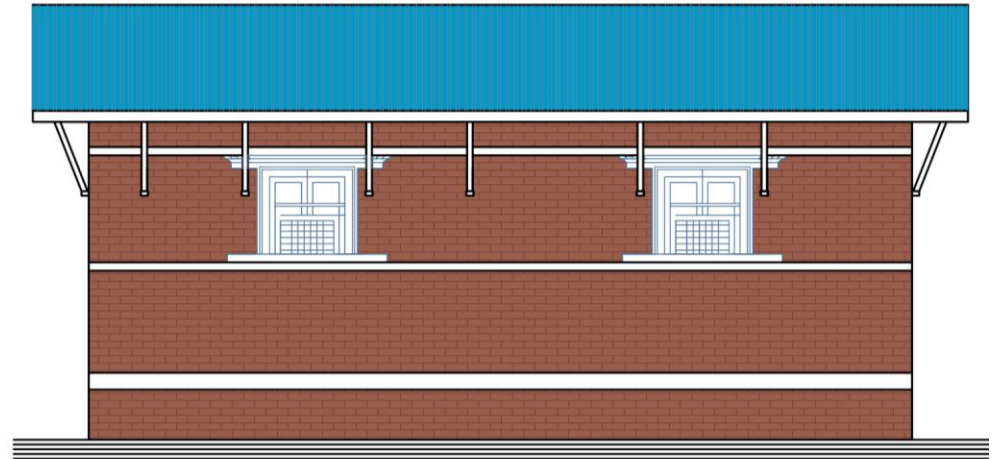

**BACK ELEVATION**



**SIDE ELEVATION**



**SIDE ELEVATION**

 <p>MINISTRY OF URBAN DEVELOPMENT DEPARTMENT OF URBAN DEVELOPMENT AND BUILDING CONSTRUCTION</p>	HOUSING TYPE: I.B.-1.3	SCALE: NONE	I.B.-1.3
	DRAWING TITLE: ELEVATIONS	DATE:	3/6

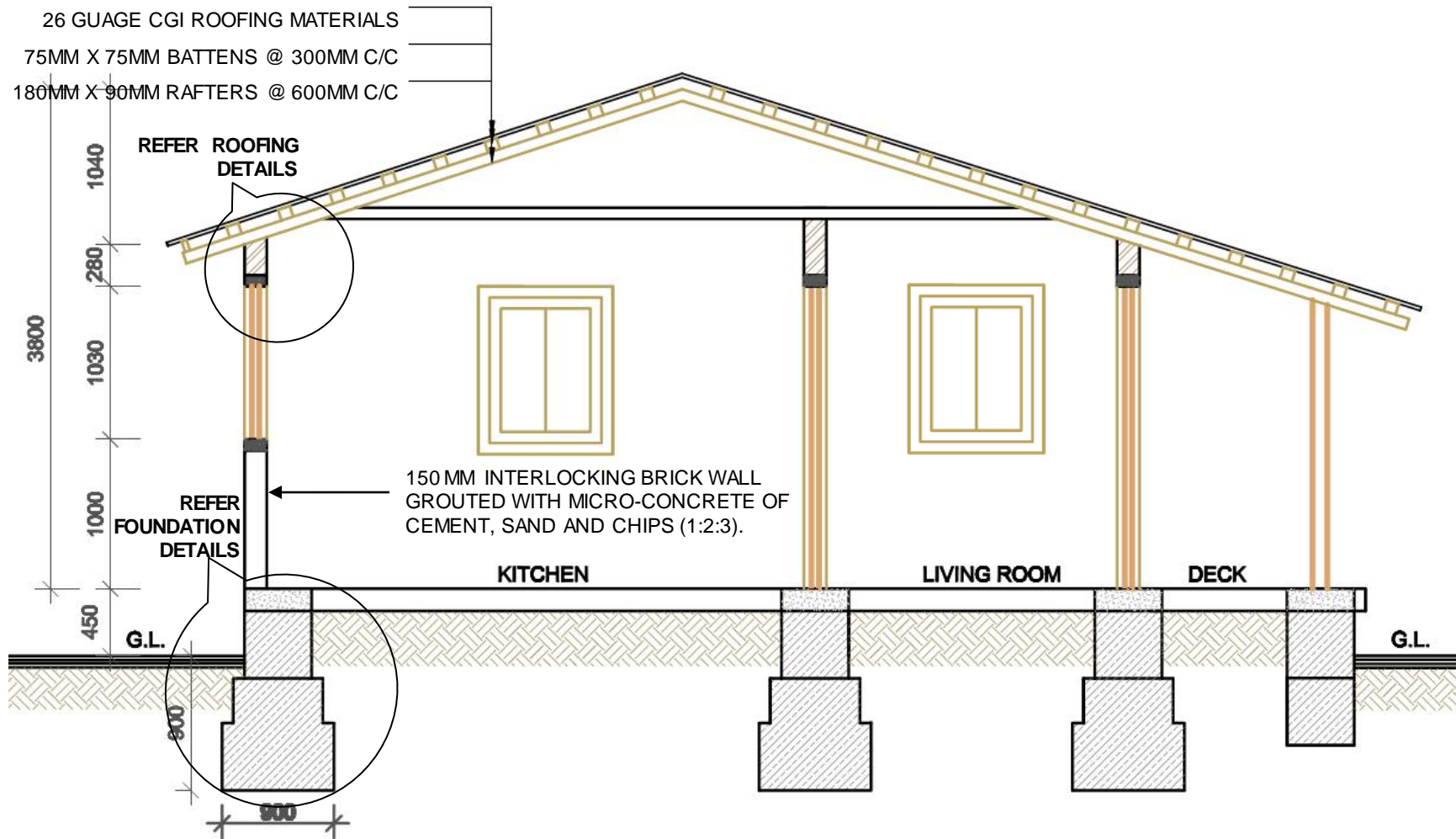

**SECTION AT A-A**



MINISTRY OF URBAN DEVELOPMENT  
 DEPARTMENT OF URBAN DEVELOPMENT AND  
 BUILDING CONSTRUCTION

HOUSING TYPE: I.B.-1.3

DRAWING TITLE: SECTION

SCALE: NONE

DATE:

I.B.-1.3

4/6



# MODEL I.B.-1.3, INTERLOCKING BRICK MASONRY

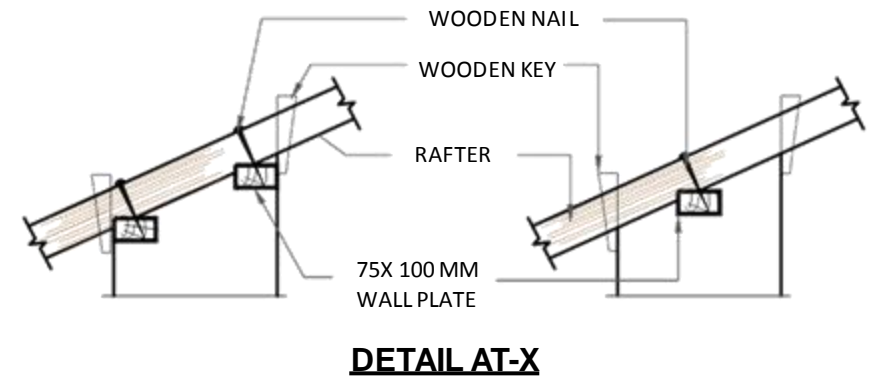
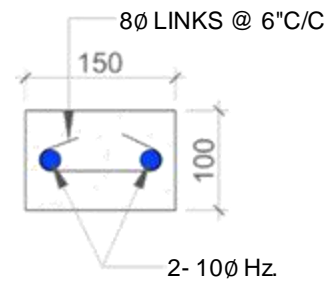
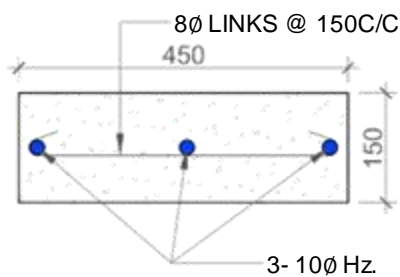
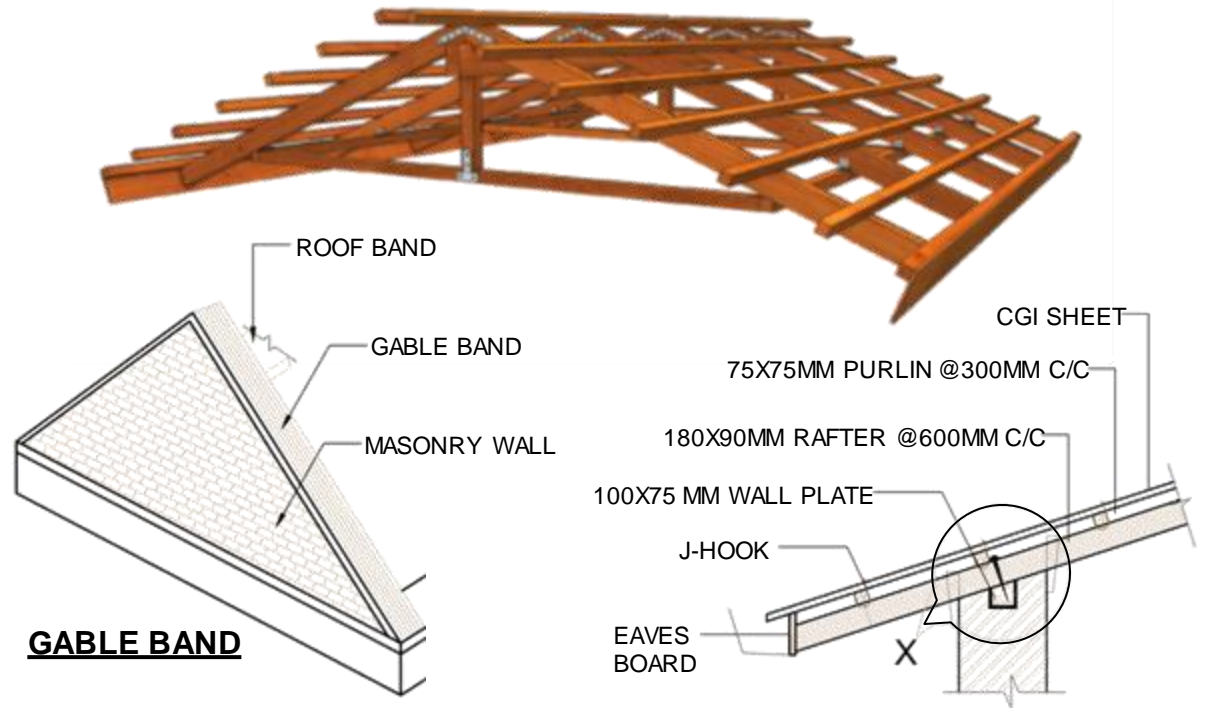
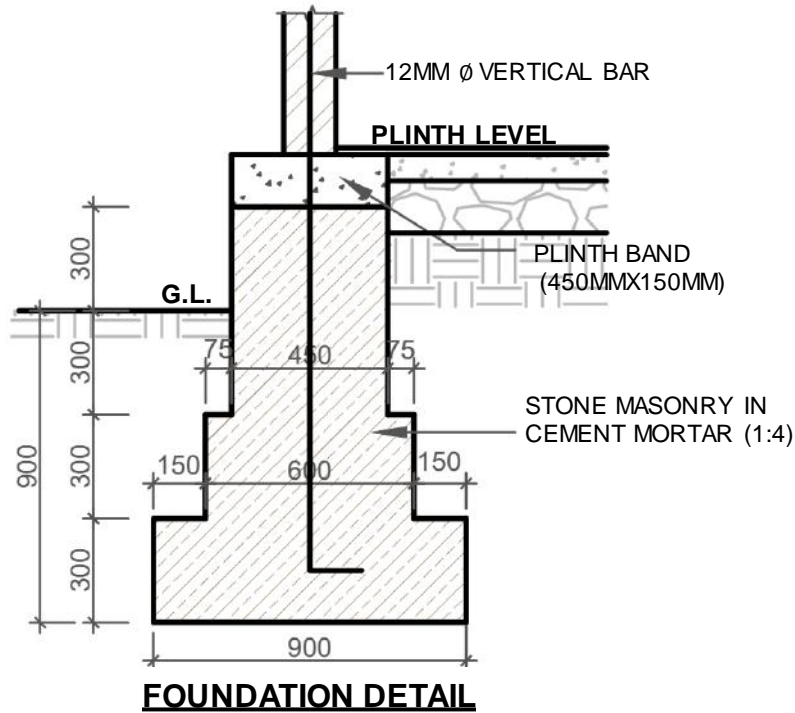

MINISTRY OF URBAN DEVELOPMENT  
DEPARTMENT OF URBAN DEVELOPMENT AND  
BUILDING CONSTRUCTION

HOUSING TYPE: I.B.-1.3

DRAWING TITLE: DETAILS

SCALE: NONE

DATE:

I.B.-1.3

5/6

**TECHNICAL REQUIREMENTS**

<b>Structure System</b>	Reinforced Stabilized Interlocking Brick Masonry Structure with horizontal and vertical reinforcing bars in strategic locations.
<b>Foundation</b>	Strip Foundation of Stone Masonry in 1:4 cement sand mortar. Foundation size is width 900mm and depth 900 mm (refer drawing).
<b>Plinth Band</b>	R.C.C (1:1.5:3) band of size 450mm x 150 mm. with 3 nos. of 10 mm Ø reinforcement and 8 mm Ø stirrups at 150 mm C/C.
<b>Wall</b>	Load bearing walls of Interlocking bricks. Interlocking bricks shall be of cement and soil mixed in 1:8 ratio. Two types of Interlocking blocks; normal and U shaped shall be used in full size (300 x 150x 100 mm) and half size (150 x 150 x 100 mm). These blocks shall be air cured for 1 day and water cured for 21 days. Minimum Compressive strength of the block shall be 3.5 Mpa. 12 mm Ø vertical bars shall be provided at corners and joints and grouted with micro concrete 1:2:3 (Cement, sand & chips) ratio. Horizontal reinforcement requirement is stated in sill and lintel details below.
<b>Sill Band</b>	Reinforced cement concrete sill band of 150x 100 mm size and 1:1.5:3 (1part cement, 1.5 parts sand and 3 parts aggregate). 2 nos. of 10 mm Ø reinforcement and 8 mm Ø stirrups at 150 mm C/C.
<b>Lintel Band:</b>	Reinforced cement concrete lintel band of 150x 100 mm size and 1:1.5:3 (1part cement, 1.5 parts sand and 3 parts aggregate). 2 nos. of 10 mm Ø reinforcement and 8 mm Ø stirrups at 150 mm C/C.
<b>Roof:</b>	Lightweight roof of corrugated iron sheet over wooden truss. All joints in the truss shall be properly connected as shown in the drawing.



# **CONFINED HOLLOW CONCRETE BLOCK MASONRY**

**C.H.C.-2.1**

Construction with Hollow concrete blocks as partition wall is not a new practice. In the technology proposed here, hollow concrete block walls carry the seismic loads and the Reinforced Concrete Columns of minimal size are used to confine the walls. Hollow concrete block walls with tothing are constructed up to sill level leaving space for columns and then columns and sill are monolithically casted. Same process is applied after constructing hollow concrete block wall up to lintel.

Featured Design in C.H.C.-2.1 is a two storied structure with six rooms. Structural system consists of load bearing hollow concrete walls confined with 15 cm x 15 cm R.C.C. Columns. The first floor is of R.C.C. slab and roofing consists of CGI sheet over wooden rafter and purlins.

### **MATERIAL PROPERTIES**

Block Size: 40cm X 15cm X20cm

Min Compressive Strength on gross area : 5 Mpa

Min Compressive Strength on net area : 7.5 Mpa

Density of the Block : 1600kg/m<sup>3</sup>

Nominal Mix Ratio: 1:1.5:3 (C:S:A)

Min Yield Strength of Reinforcing Steel: 415 MPa

# **C.H.C.-2.1**



LEVEL	MATERIALS								
	Stone	Hollow Concrete Bricks	Cement	Sand	Aggregate	Reinforcing Bar	CGI sheet	GI Sheet	Wood
	Cu.m	No.	Bags	Cu.m.	Cu.m.	Kg.	Bundle	Sq.m.	Cu.m.
Up to Plinth Level	30.3	-	78	12.3	3.5	252.0			-
Super Structure	-	1,330.0	102	8.7	7.5	1,388.0			1.5
Roofing	-						5.0	6.5	1.7
<b>TOTAL</b>	<b>30.3</b>	<b>1,330.0</b>	<b>180</b>	<b>21.0</b>	<b>11.0</b>	<b>1,640.0</b>	<b>5.0</b>	<b>6.5</b>	<b>3.2</b>



# MODEL C.H.C.-2.1, CONFINED HOLLOW CONCRETE BLOCK MASONRY

TWO STOREY

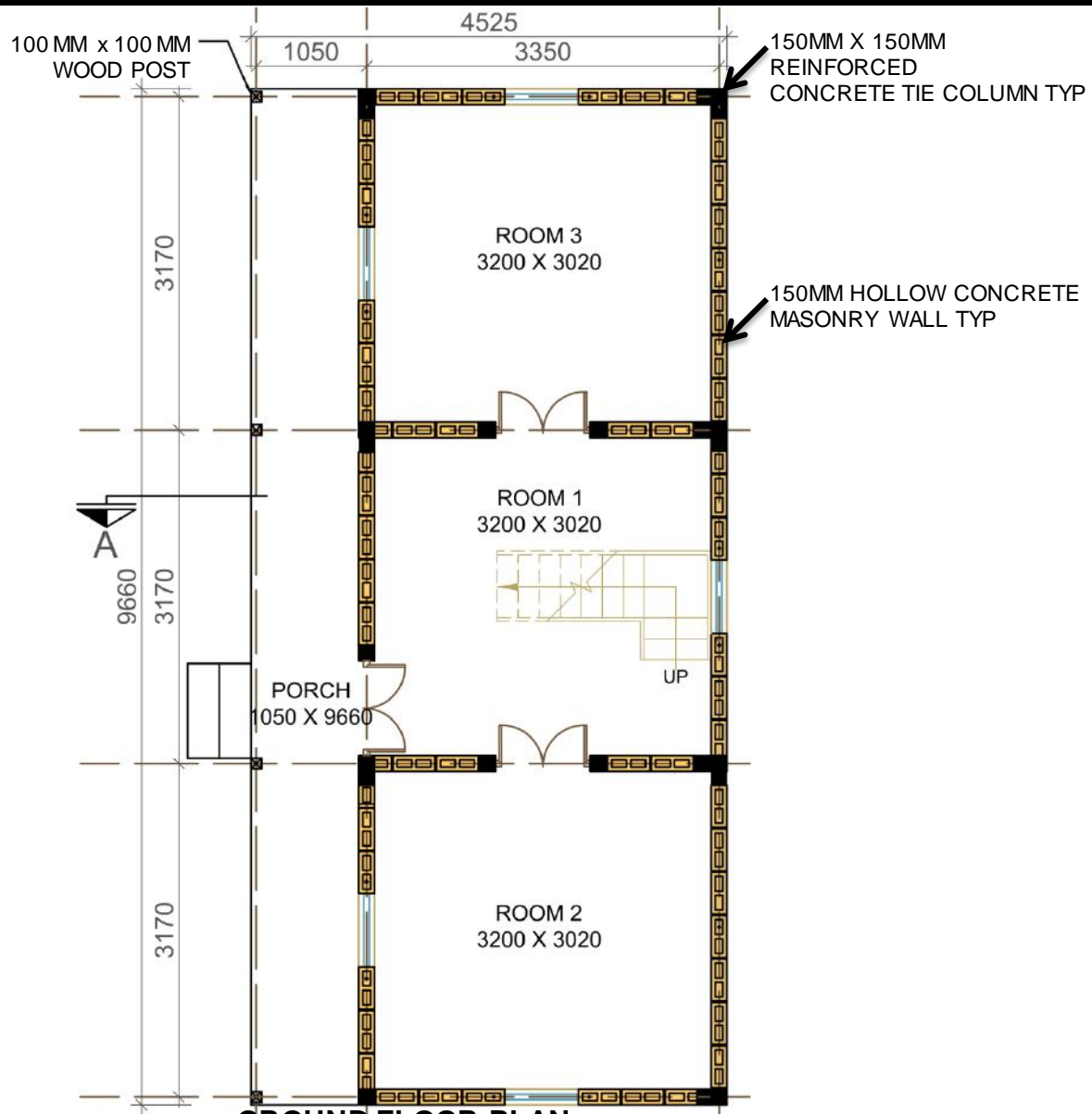

**GROUND FLOOR PLAN**

FLOOR AREA: 43.71 SQ.M.

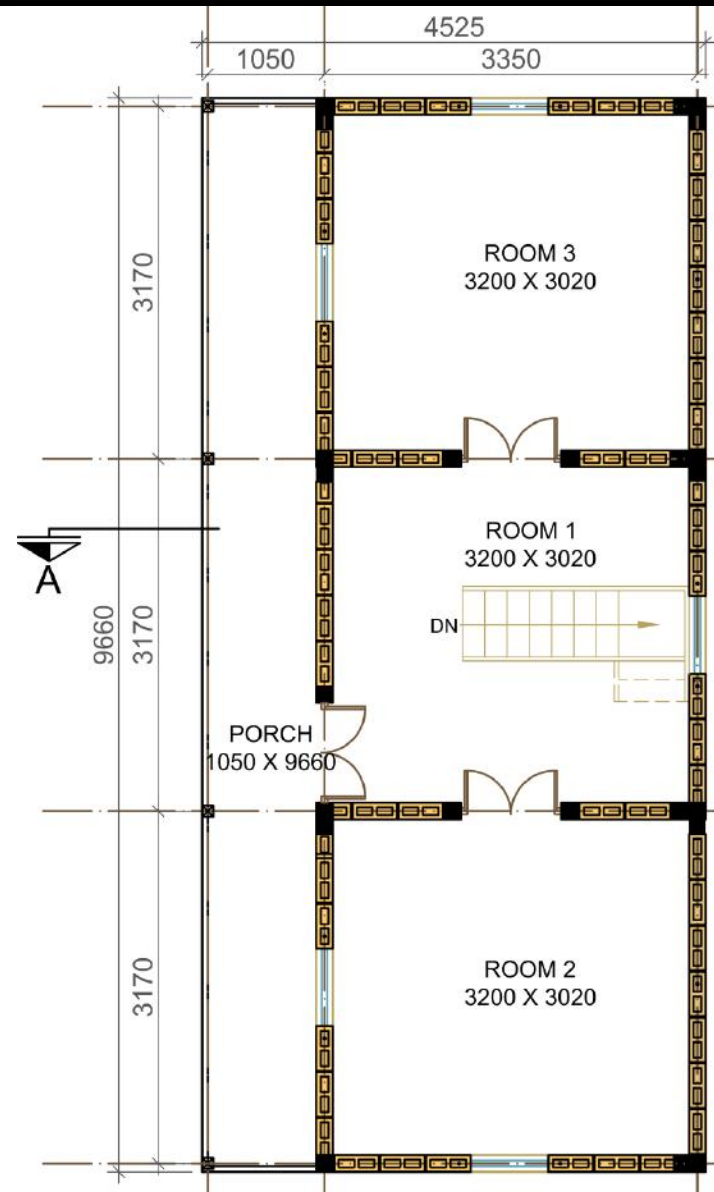

**FIRST FLOOR PLAN**

FLOOR AREA: 43.71 SQ.M.



MINISTRY OF URBAN DEVELOPMENT  
DEPARTMENT OF URBAN DEVELOPMENT AND  
BUILDING CONSTRUCTION

HOUSING TYPE: MODEL C.H.C.-2.1

DRAWING TITLE: FLOOR PLANS

SCALE: NONE

DATE:

C.H.C.-2.1

2/11



**FRONT ELEVATION**



**SIDE ELEVATION**



**SIDE ELEVATION**



**BACK ELEVATION**



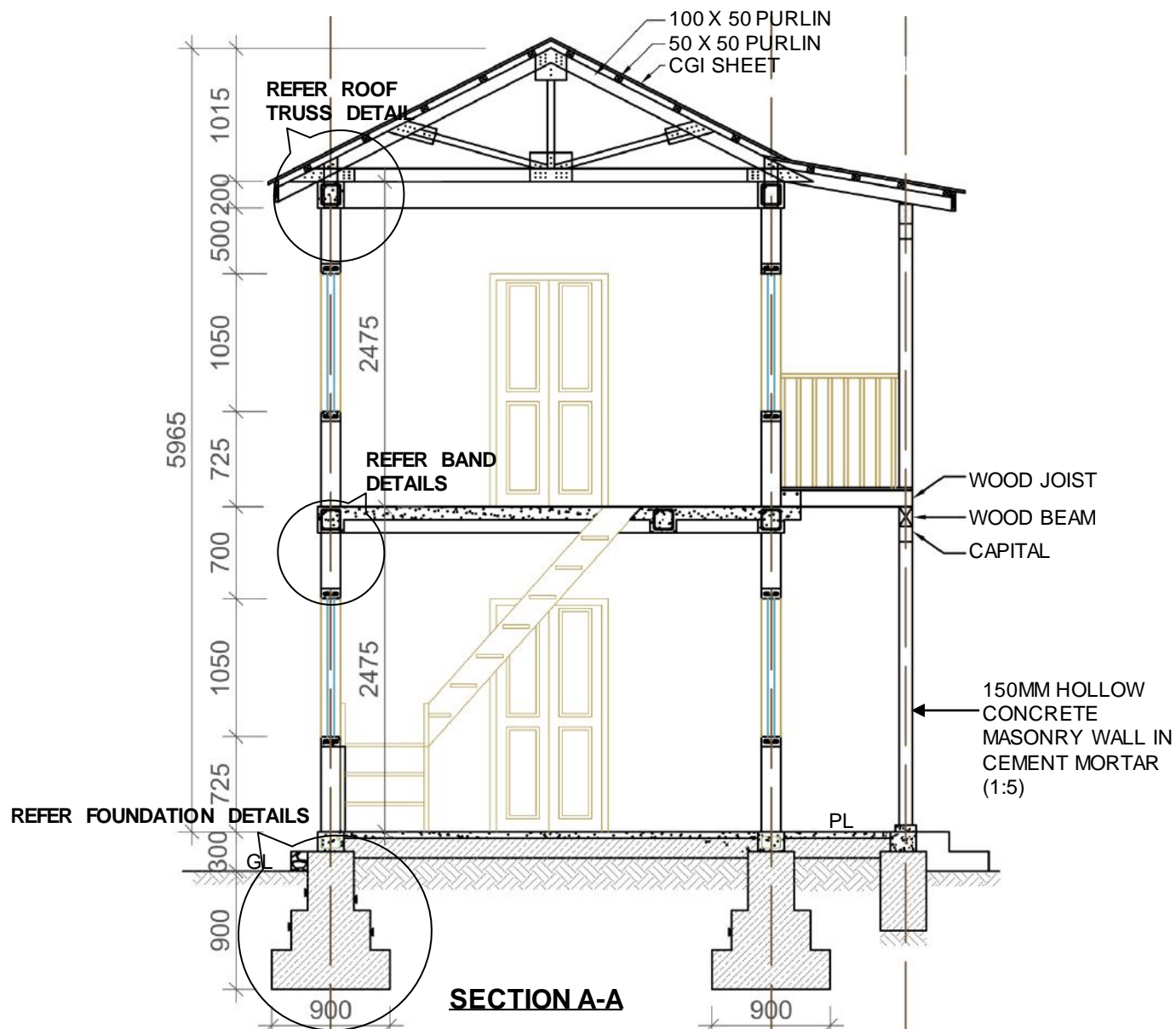

MINISTRY OF URBAN DEVELOPMENT  
DEPARTMENT OF URBAN DEVELOPMENT AND  
BUILDING CONSTRUCTION

HOUSING TYPE: MODEL C.H.C.-2.1

DRAWING TITLE: SECTION

SCALE: NONE

DATE:

C.H.C.-2.1  
4/11



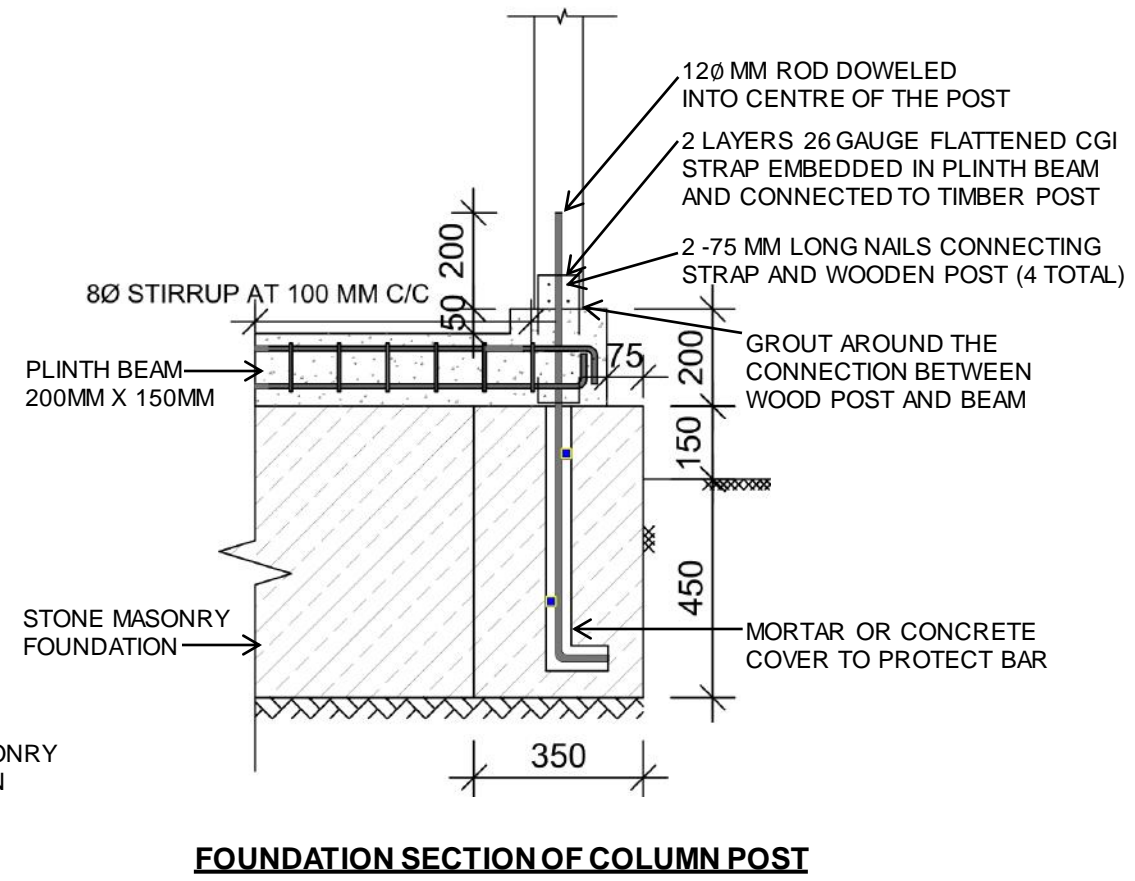
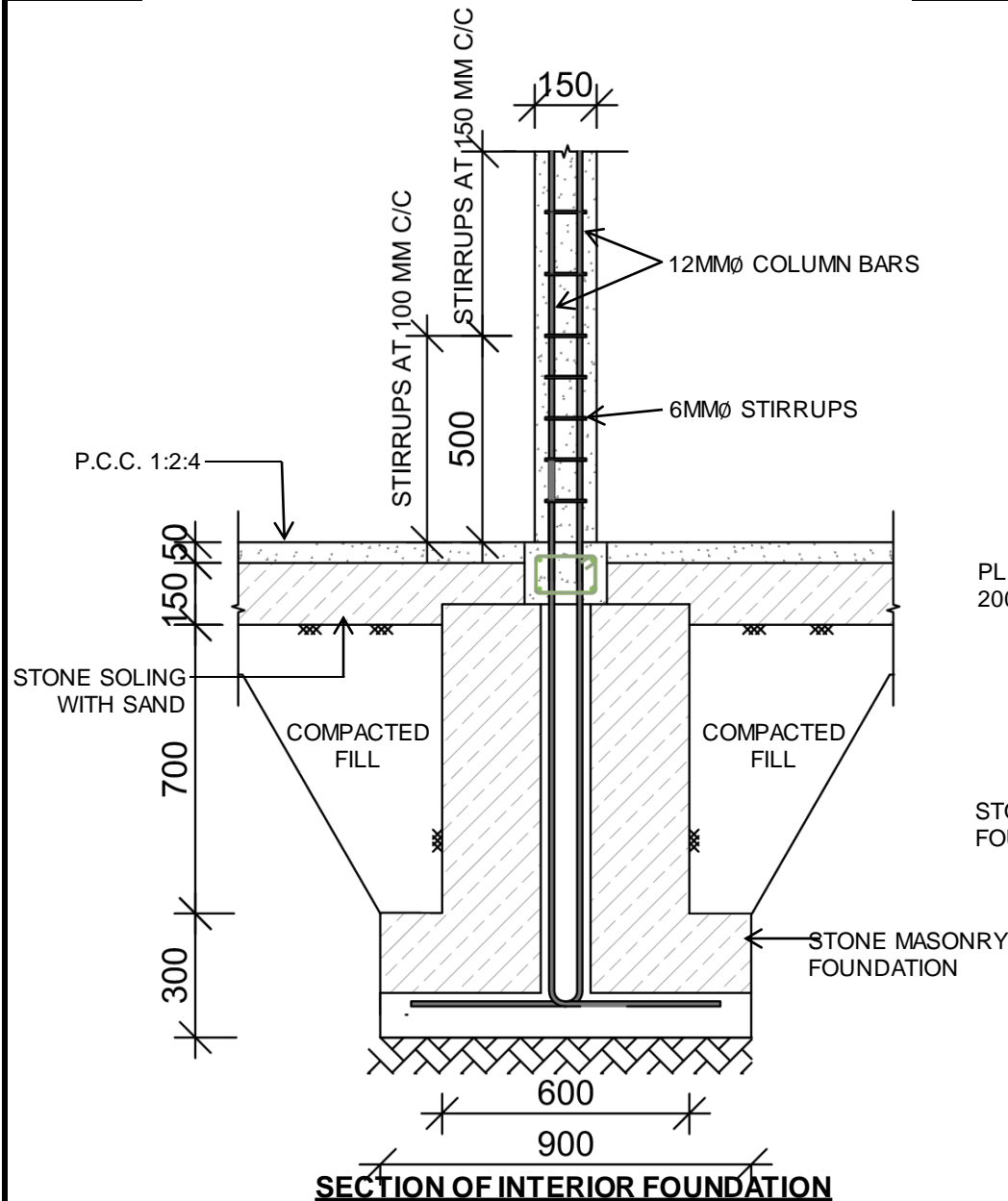

FOUNDATION DETAILS

 <p>MINISTRY OF URBAN DEVELOPMENT DEPARTMENT OF URBAN DEVELOPMENT AND BUILDING CONSTRUCTION</p>	HOUSING TYPE: MODEL C.H.C.-2.1	SCALE: NONE	C.H.C.-2.1 5/11
	DRAWING TITLE: DETAILS	DATE:	

# MODEL C.H.C.-2.1, CONFINED HOLLOW CONCRETE BLOCK MASONRY

# TWO STOREY

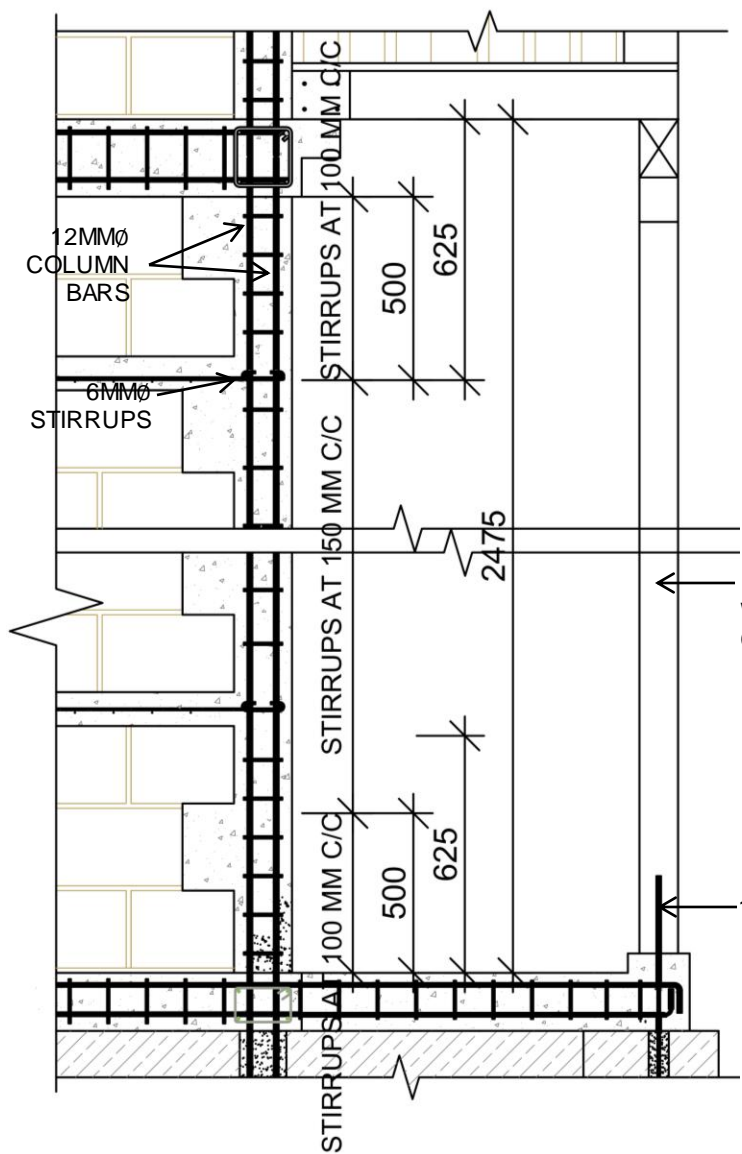

**TYPICAL COLUMN SECTION: FROM GL TO FIRST FLOOR**

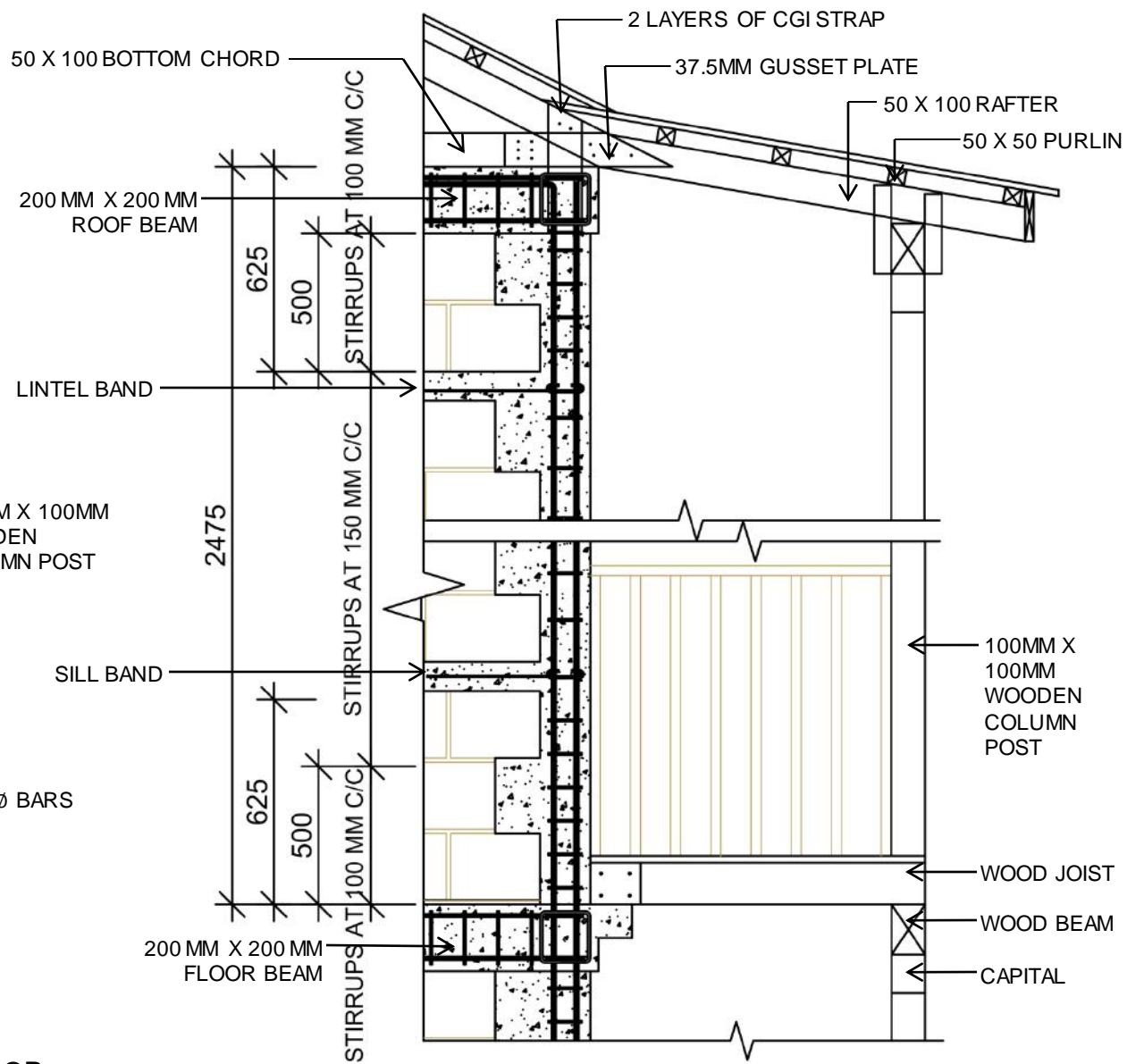

**TYPICAL COLUMN SECTION: FROM FIRST FLOOR TO ROOF**

 <p>MINISTRY OF URBAN DEVELOPMENT DEPARTMENT OF URBAN DEVELOPMENT AND BUILDING CONSTRUCTION</p>	HOUSING TYPE: MODEL C.H.C.-2.1	SCALE: NONE	C.H.C.-2.1 6/11
	DRAWING TITLE: DETAILS	DATE:	

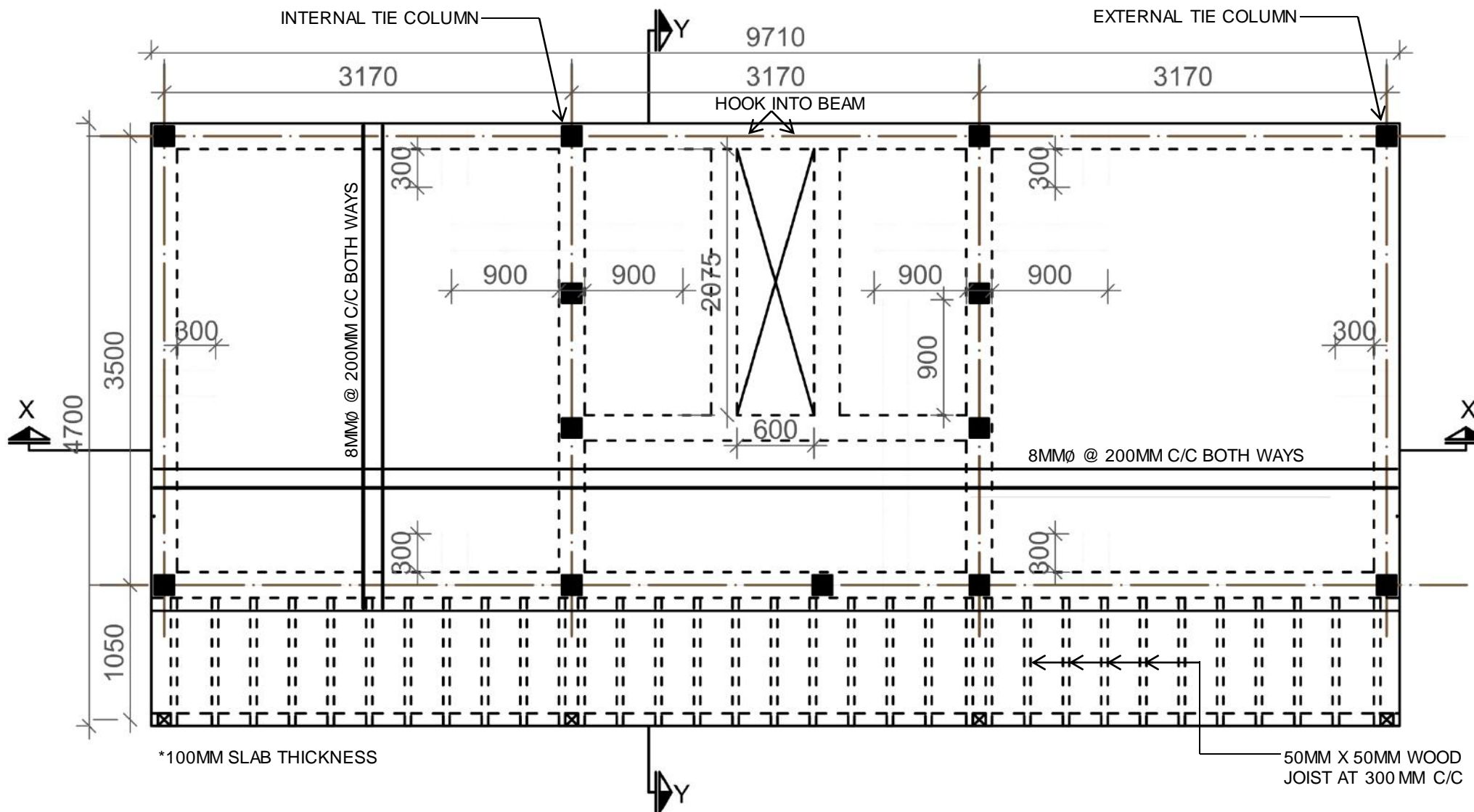

FLOOR SLAB DETAILING



MINISTRY OF URBAN DEVELOPMENT  
DEPARTMENT OF URBAN DEVELOPMENT AND  
BUILDING CONSTRUCTION

HOUSING TYPE: MODEL C.H.C.-2.1

DRAWING TITLE: DETAILS

SCALE: NONE

DATE:

C.H.C.-2.1

7/11

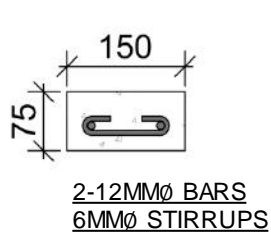

**SILL/ LINTEL BAND**

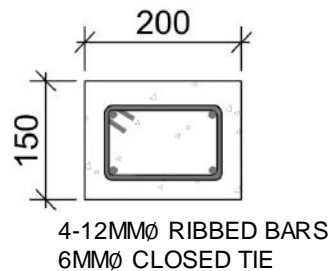

**PLINTH BAND**

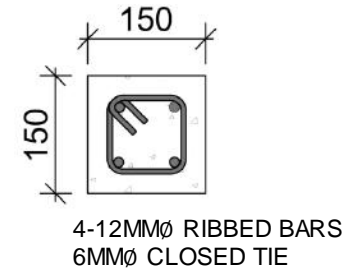

**TIE COLUMN PLAN**

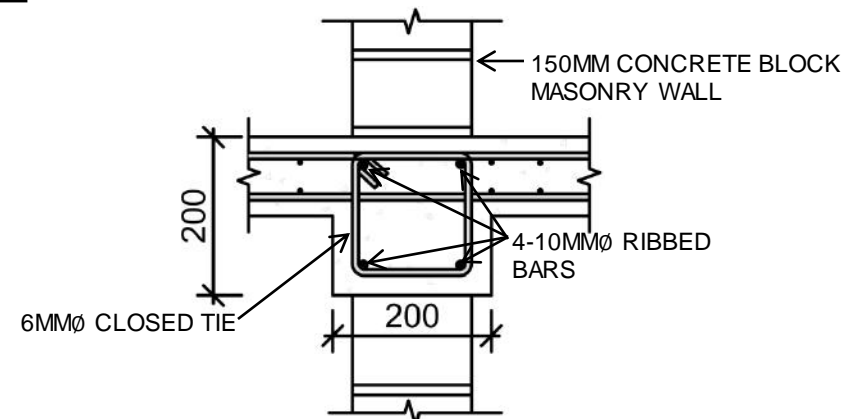
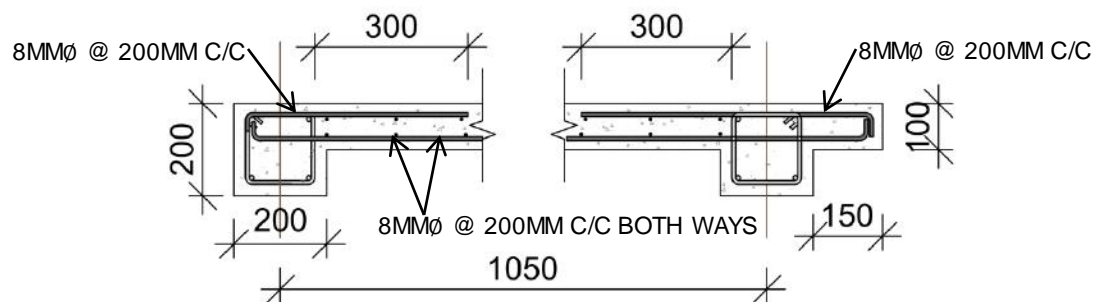
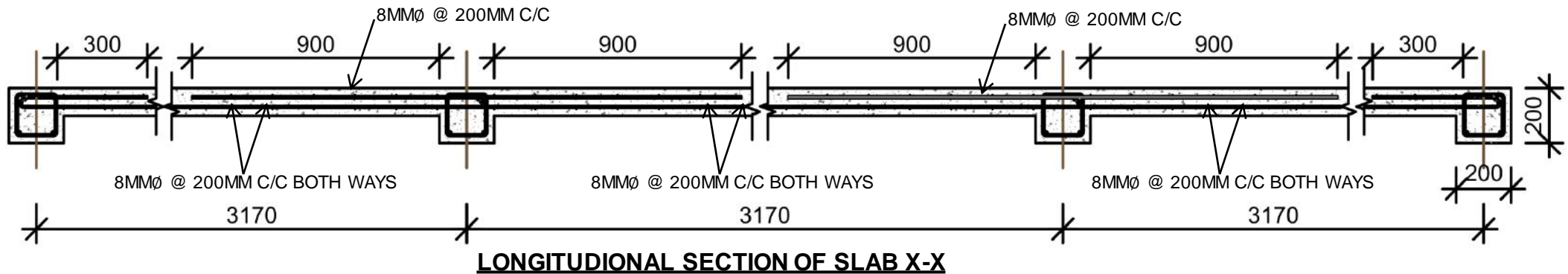

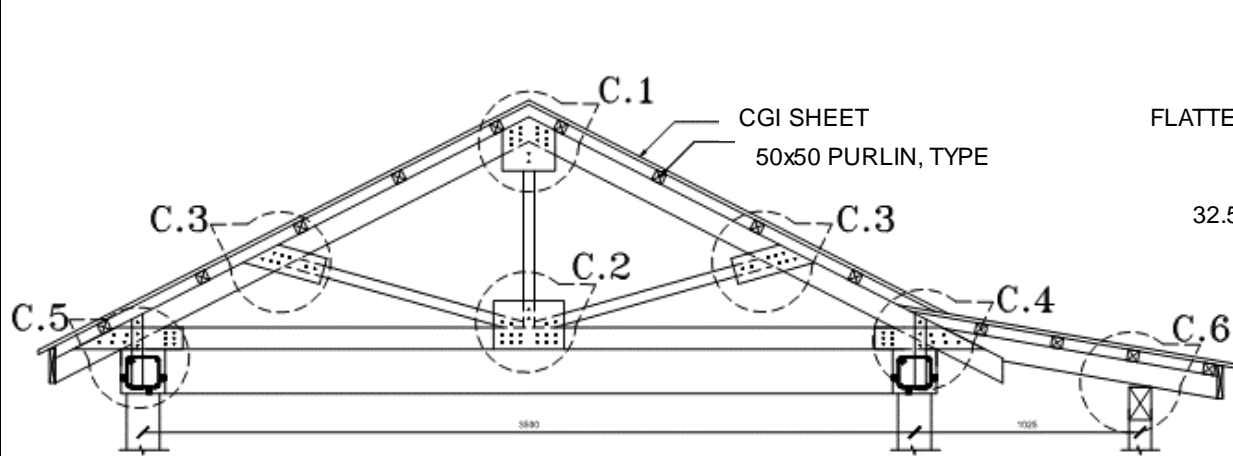

**ROOF TRUSS ELEVATION WITH GUSSET PLATE**

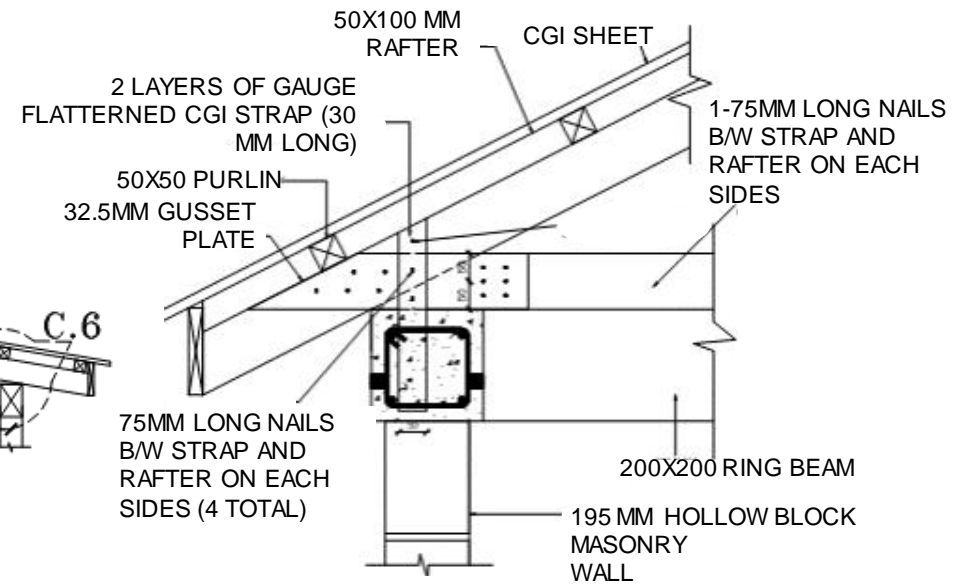

**DETAIL OF CGI STRAP**

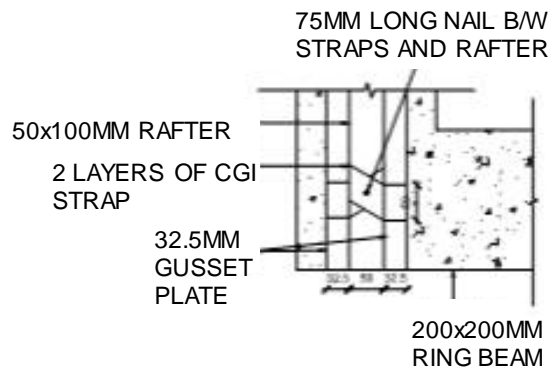

**PLAN**

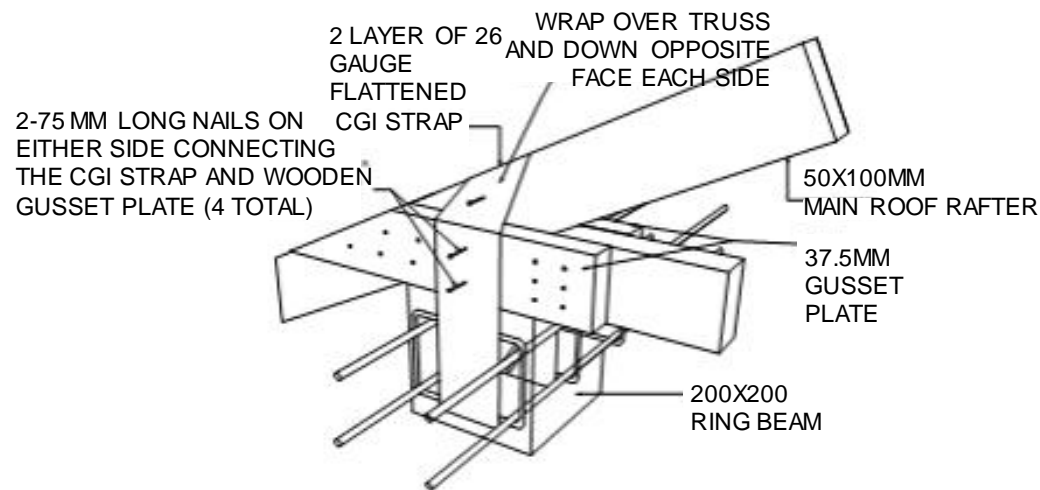

**3D VIEW CGI STRAP CONNECTION**

ALL DIMENSIONS ARE IN MM



MINISTRY OF URBAN DEVELOPMENT  
DEPARTMENT OF URBAN DEVELOPMENT AND  
BUILDING CONSTRUCTION

HOUSING TYPE: MODEL C.H.C.-2.1

DRAWING TITLE: DETAILS

SCALE: NONE

DATE:

C.H.C.-2.1

9/11

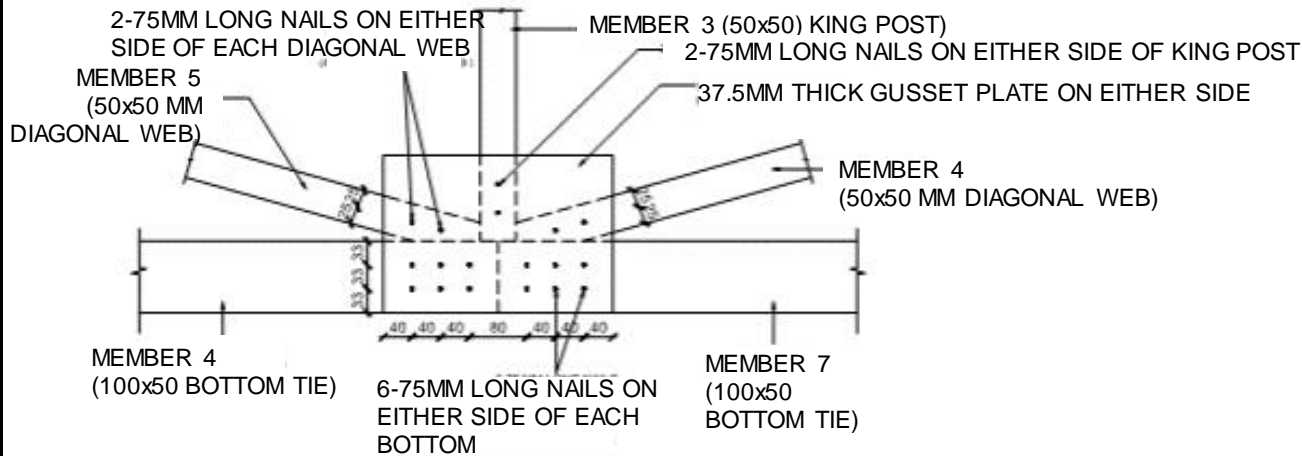

**DETAIL AT CONNECTION 2**

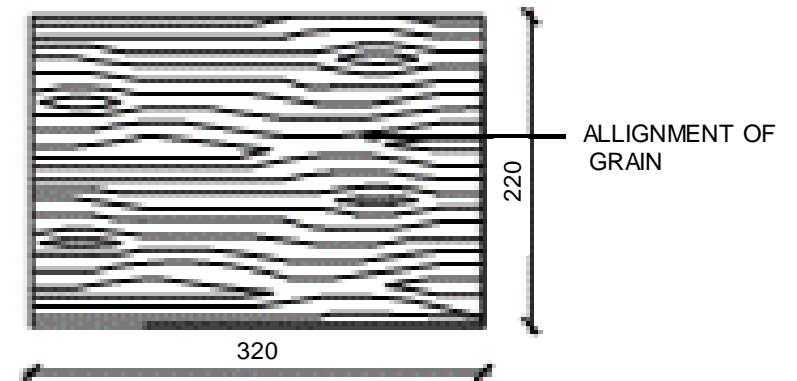

**DETAIL OF GUSSET PLATE**

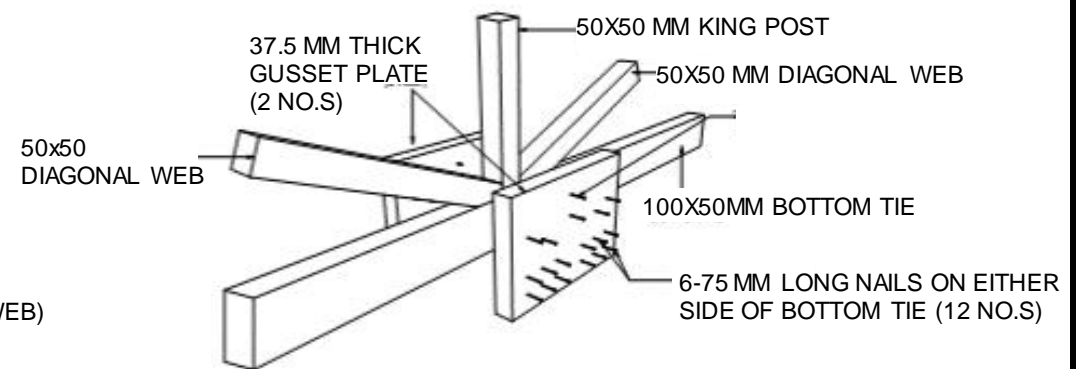
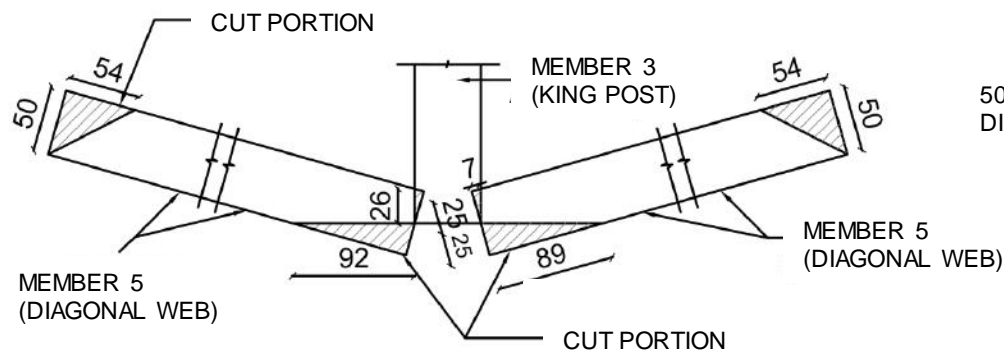

**TECHNICAL REQUIREMENTS**

<b>Structure System</b>	Confined Masonry structure. Structural system shall be of hollow concrete block masonry panels and slender cast in situ vertical and horizontal confining Reinforced concrete elements; tie columns and tie beams. Masonry walls shall be constructed first and then tie columns shall be casted in place. Tothing shall be ensured for proper connection between wall and tie columns.
<b>Foundation</b>	Strip foundation with stone masonry casing the tie column. The depth and width of footing shall be 900mm.
<b>Plinth Band</b>	Tie Beam of reinforced concrete of width 200 mm and depth 150mm. Main reinforcement 4 nos.12mm Ø bars with 6mm Ø stirrups at 150mm C/C.
<b>Wall System</b>	The hollow blocks of size 400 x 150 x 200 mm shall be of good quality and shall adhere to the Nepal Standards of block production. The mortar shall be 1: 5 (cement: sand) or richer. The thickness of wall shall be greater than or equal to 150mm.
<b>Sill Band</b>	A continuous reinforced concrete sill band shall be provided throughout the entire wall at the bottom level of openings. The minimum depth of the band shall be 75mm. Main reinforcement shall be 2 nos.12mm dia. bars with 6mm Ø stirrups at 150mm C/C.
<b>Lintel Band:</b>	A continuous reinforced concrete Lintel band shall be provided throughout the entire wall at the top level of the openings. The minimum depth of the band shall be 75mm. Main reinforcement shall be 2 nos.12mm dia. bars with 6mm Ø stirrups at 150mm C/C.
<b>Floor Beam:</b>	Floor Beam of reinforced concrete with 200 mm width and 200 mm depth. Main reinforcement shall be 4 nos. 12mm Ø bars with 6mm Ø stirrups at 150mm C/C
<b>Floor:</b>	100 mm thick reinforced concrete slab as shown in detail drawing.
<b>Roof:</b>	Lightweight roof of corrugated iron sheet over wooden truss. All joints in the truss shall be properly connected as shown in the drawing. All trusses shall be properly cross tied with wooden braces as shown in the drawing.



# HOLLOW CONCRETE BLOCK MASONRY

**H.C.B.-3.1**



This technology proposes load bearing structure of hollow concrete blocks. Hollow concrete blocks are seen as a good alternative to conventional brick masonry as they can be locally manufactured, cheaper and environment friendly.

Featured Design in H.C.B. 3.1 is a two storied residence with four rooms. Design features are RCC strip foundation, load bearing hollow concrete walls, precast floor and roof, precast stair slabs, horizontal bands and vertical seismic reinforcement at critical sections. The design is of modular type, affordable, structurally sound and environment friendly.

### **MATERIAL PROPERTIES**

Block Size: 40cm X 20cm X10cm

Section of pre- cast Beam : Tapered width (75mmx125mm) x Height 200mm

Min Compressive strength of block : 5 N/mm<sup>2</sup>

Grade of Steel : Fe 500Mpa

Nominal Mix Ratio: 1:1.5:3 (C:S:A)



# **H.C.B.-3.1**



LEVEL	MATERIALS					
	Hollow Concrete Bricks	Cement	Sand	Aggregate	Reinforcing Bar	Polythene sheet
	No.	Bags	Cu.m.	Cu.m.	Kg.	Sq.m
Up to Plinth Level	447.0	100	6.1	12.1	864.6	19.7
Super Structure	2,398.0	163	8.6	17.5	1,677.3	
Roofing						
<b>TOTAL</b>	<b>2,845.0</b>	<b>263</b>	<b>14.7</b>	<b>29.6</b>	<b>2,541.9</b>	<b>19.7</b>



MINISTRY OF URBAN DEVELOPMENT  
DEPARTMENT OF URBAN DEVELOPMENT AND  
BUILDING CONSTRUCTION

HOUSING TYPE: MODEL H.C.B.-3.1

SCALE: NONE

HCB-3.1

DRAWING TITLE: ESTIMATE AND 3D-VIEW

DATE:

1/11

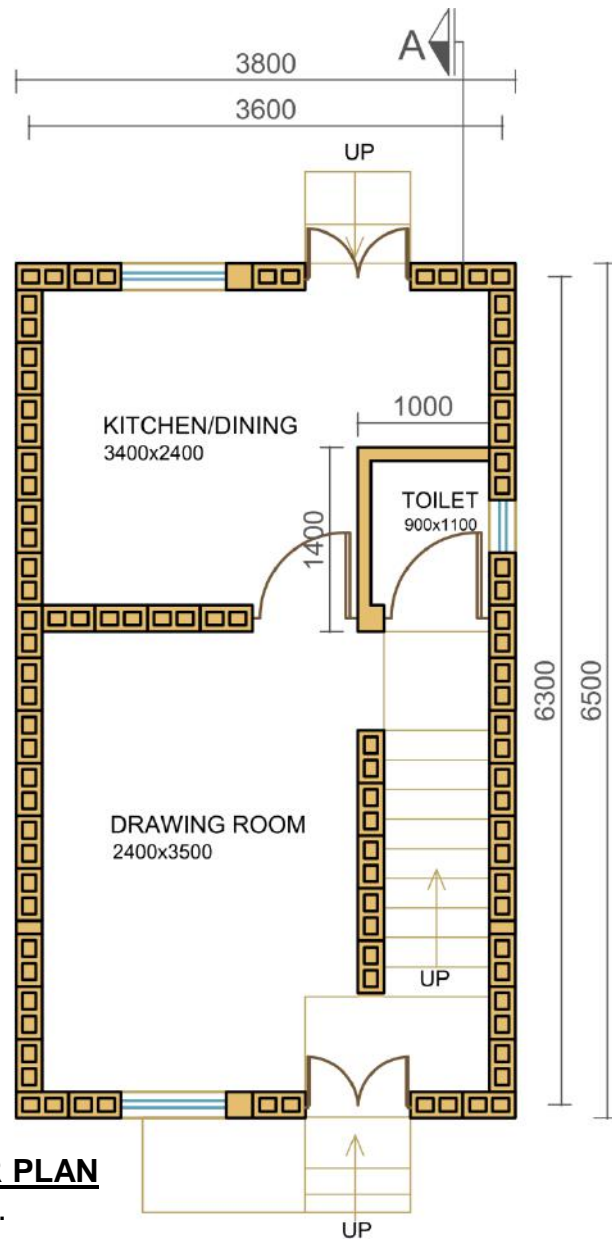

**GROUND FLOOR PLAN**  
AREA: 24.7 SQ.M.

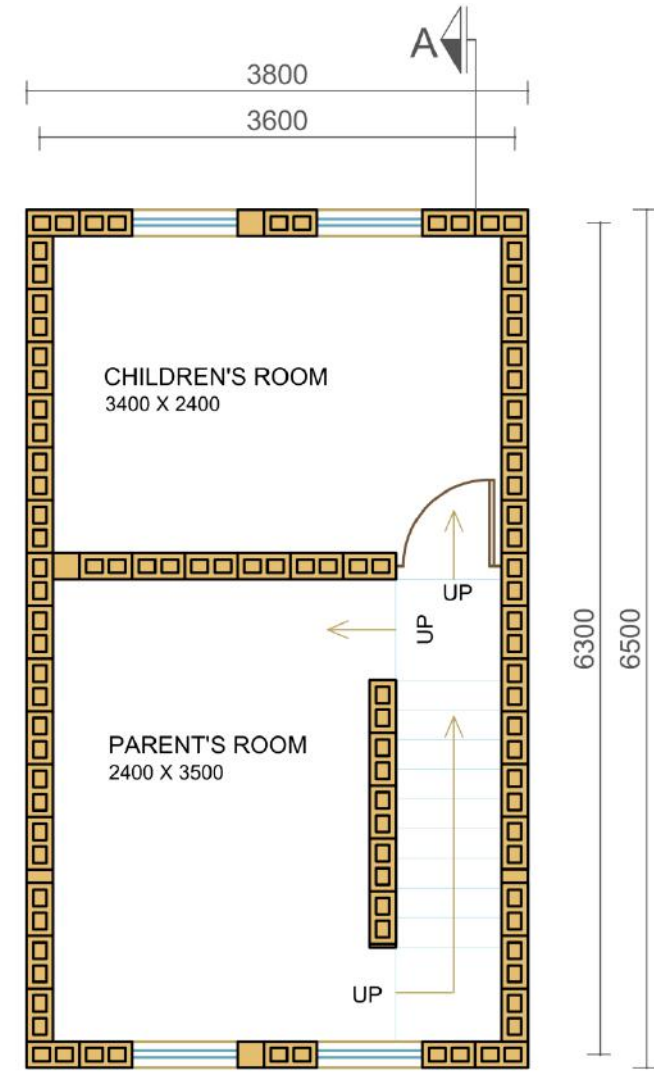

**FIRST FLOOR PLAN**  
AREA: 24.7 SQ.M.



MINISTRY OF URBAN DEVELOPMENT  
DEPARTMENT OF URBAN DEVELOPMENT AND  
BUILDING CONSTRUCTION

HOUSING TYPE: MODEL H.C.B.-3.1

DRAWING TITLE: FLOOR PLANS

SCALE: NONE

DATE:

HCB-3.1

2/11

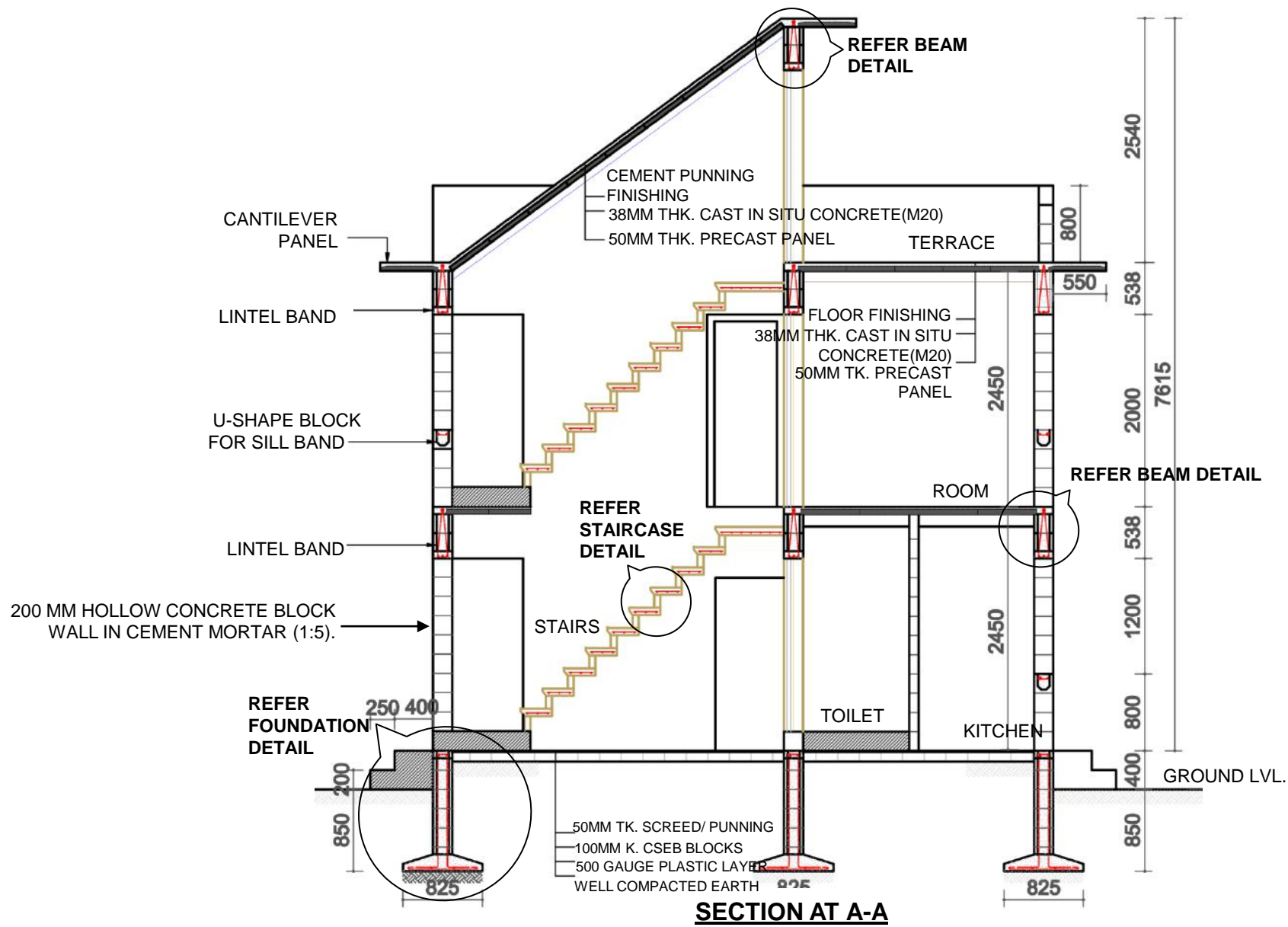

 <p>MINISTRY OF URBAN DEVELOPMENT DEPARTMENT OF URBAN DEVELOPMENT AND BUILDING CONSTRUCTION</p>	HOUSING TYPE: MODEL H.C.B.-3.1	SCALE: NONE	HCB-3.1 3/11
	DRAWING TITLE: SECTION	DATE:	

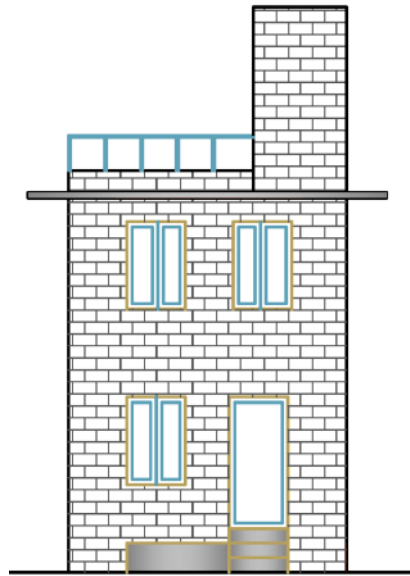

**FRONT ELEVATION**

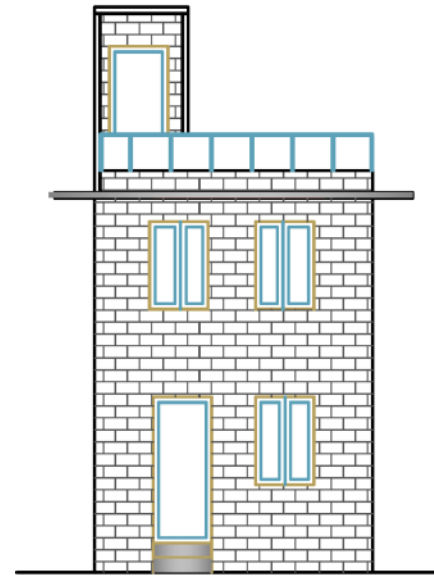

**BACK ELEVATION**

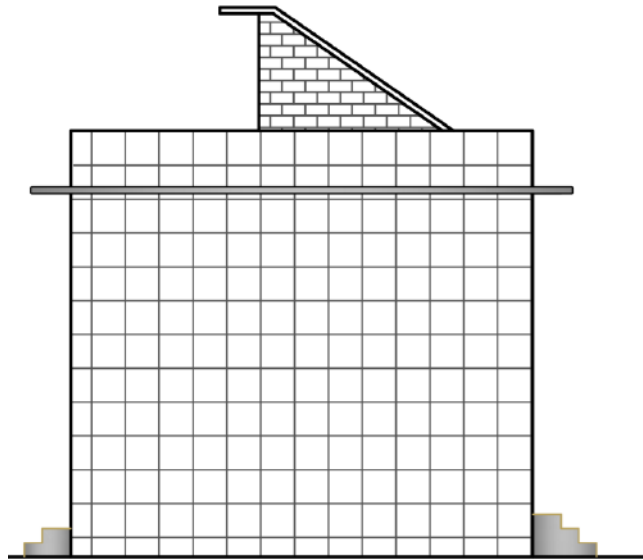

**SIDE ELEVATION**

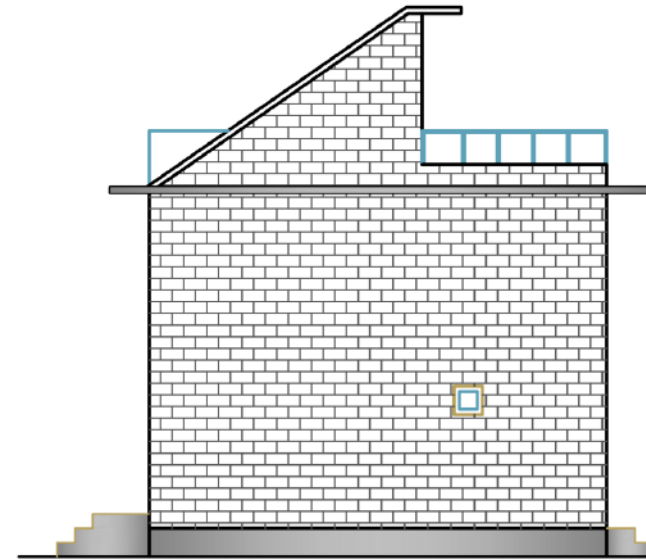

**SIDE ELEVATION**



MINISTRY OF URBAN DEVELOPMENT  
DEPARTMENT OF URBAN DEVELOPMENT AND  
BUILDING CONSTRUCTION

HOUSING TYPE: MODEL H.C.B.-3.1

DRAWING TITLE: ELEVATIONS

SCALE: NONE

DATE:

HC B-3.1

4/11

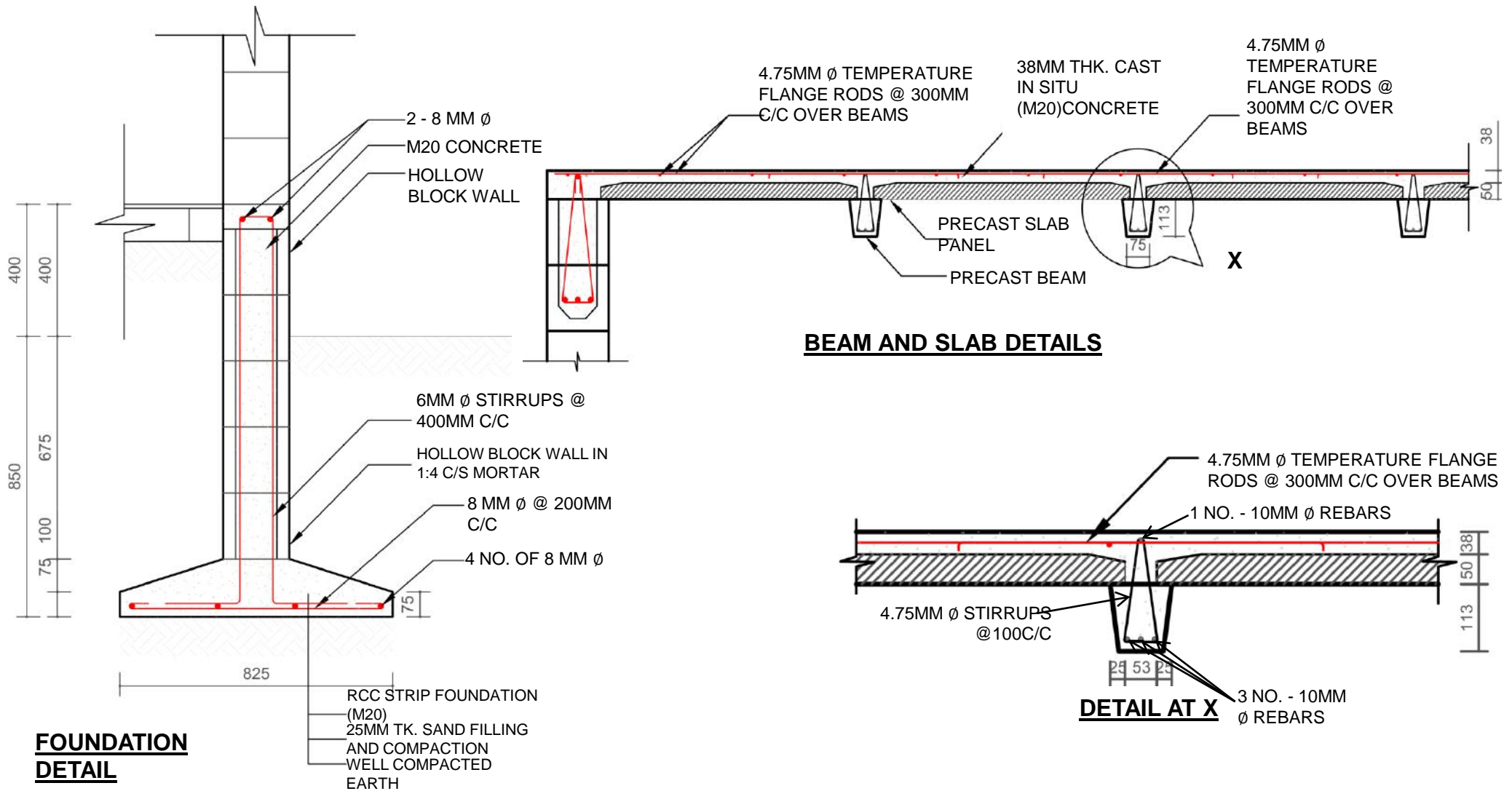

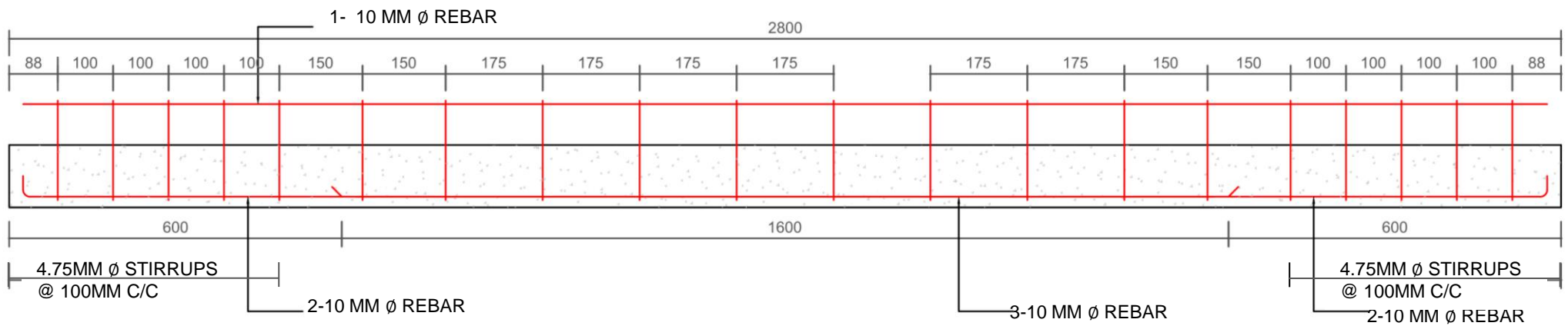
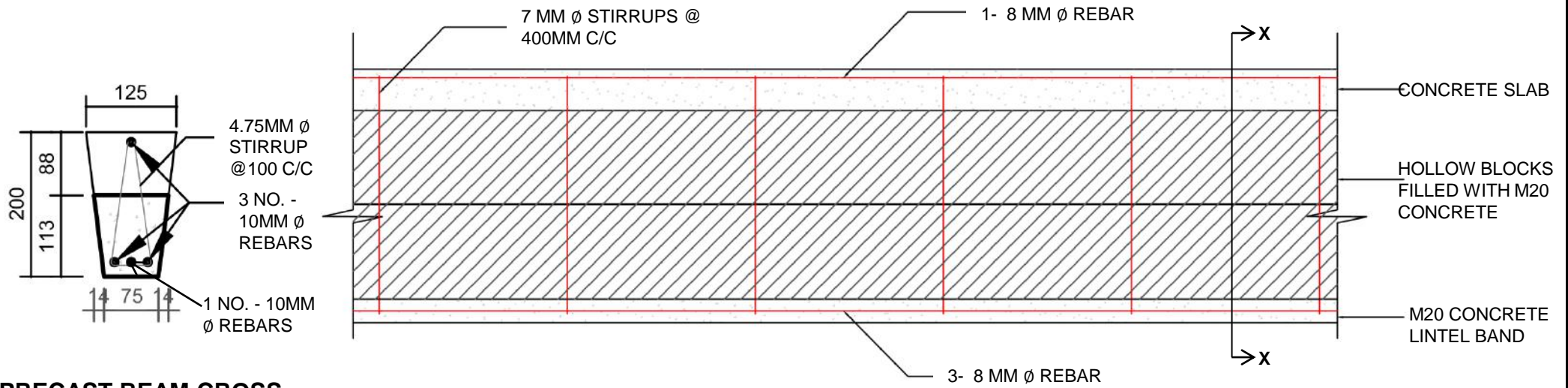

MINISTRY OF URBAN DEVELOPMENT  
DEPARTMENT OF URBAN DEVELOPMENT AND  
BUILDING CONSTRUCTION

HOUSING TYPE: MODEL H.C.B.-3.1

DRAWING TITLE: DETAILS

SCALE: NONE

DATE:

HCB-3.1

6/11

# MODEL H.C.B.- 3.1, HOLLOW CONCRETE BLOCK MASONRY

# TWO STOREY

SLAB(S1) DETAILS

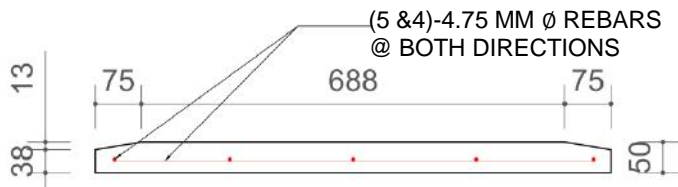
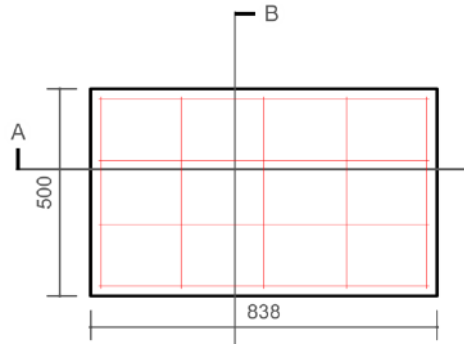
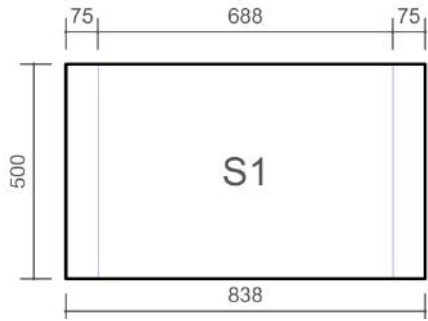

**SECTION AT A-A**

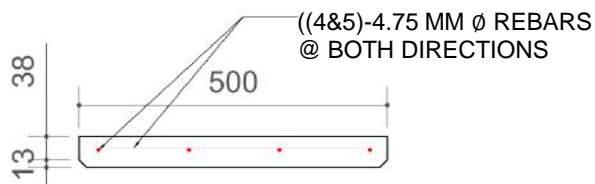

**SECTION AT B-B**

SLAB(S2) DETAILS

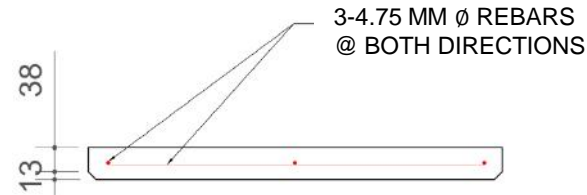
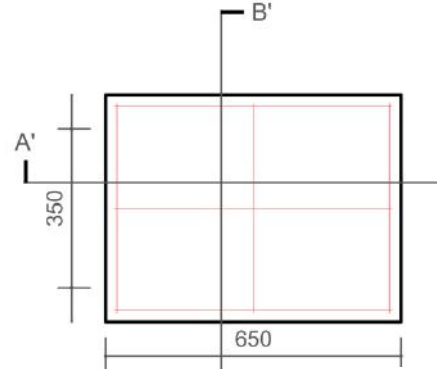
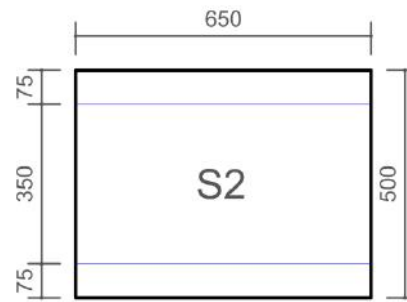

**SECTION AT A-A**

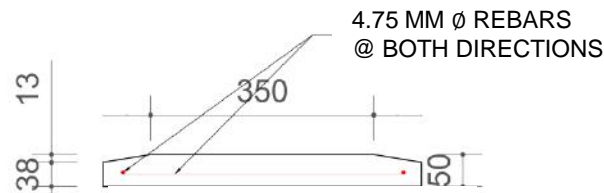

**SECTION AT B-B**

SLAB(S3) DETAILS

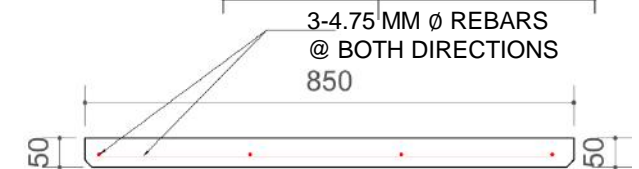
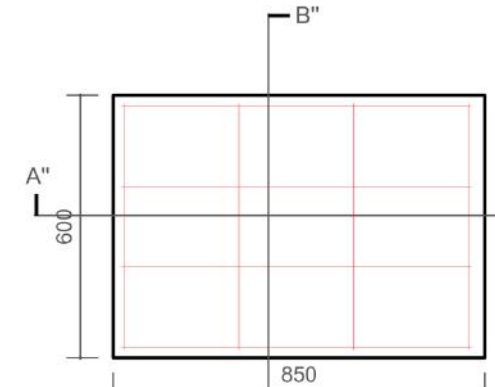

**SECTION AT B-B**

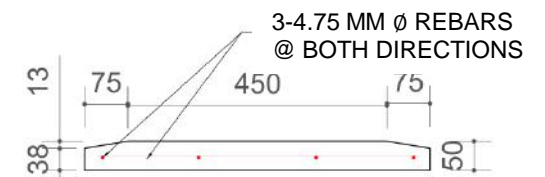

MINISTRY OF URBAN DEVELOPMENT  
DEPARTMENT OF URBAN DEVELOPMENT AND  
BUILDING CONSTRUCTION

HOUSING TYPE: MODEL H.C.B.-3.1

DRAWING TITLE: DETAILS

SCALE: NONE

DATE:

HCB-3.1

7/11



# MODEL H.C.B.- 3.1, HOLLOW CONCRETE BLOCK MASONRY

TWO STOREY

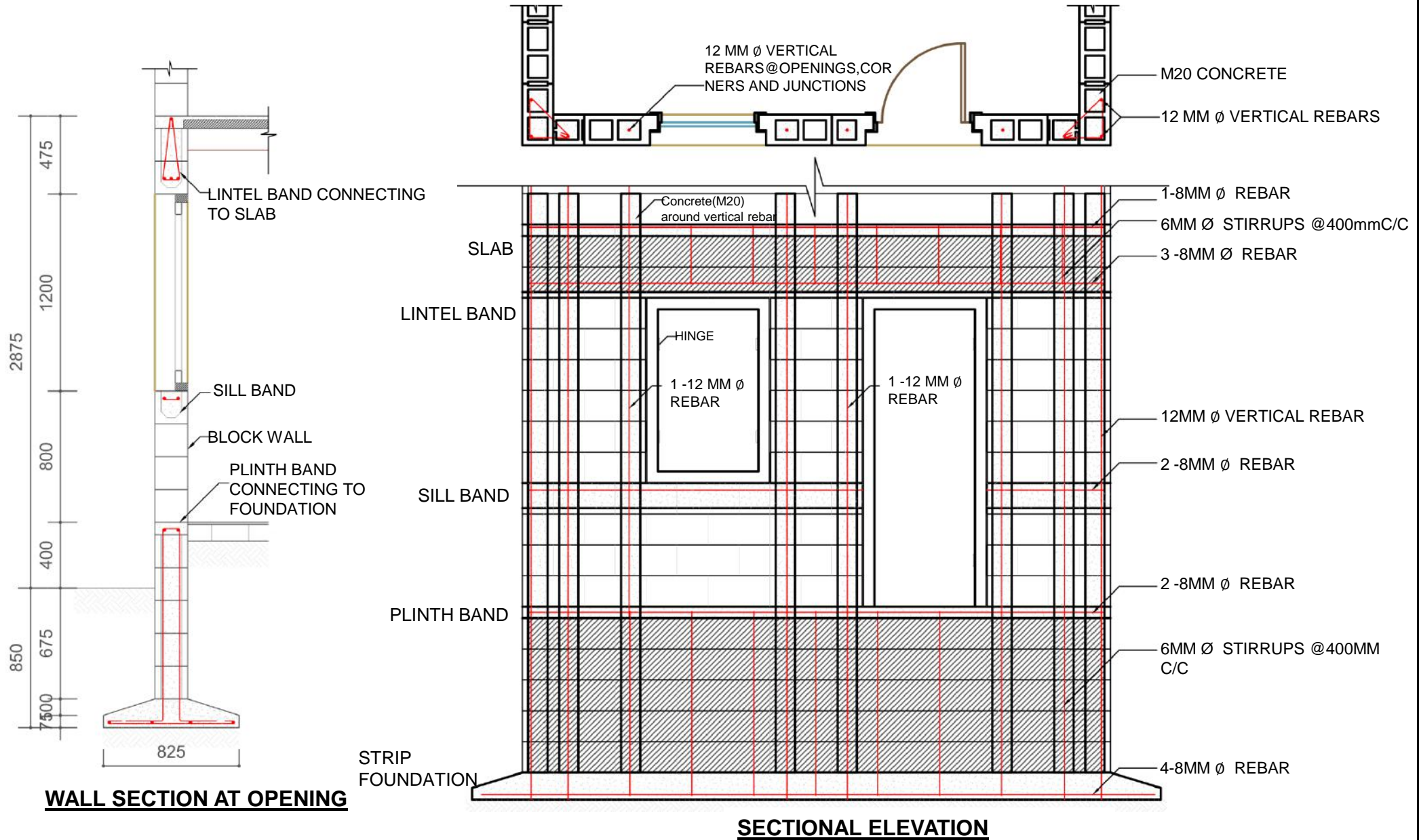

MINISTRY OF URBAN DEVELOPMENT  
DEPARTMENT OF URBAN DEVELOPMENT AND  
BUILDING CONSTRUCTION

HOUSING TYPE: MODEL H.C.B.-3.1

DRAWING TITLE: DETAILS

SCALE: NONE

DATE:

HCB-3.1

8/11

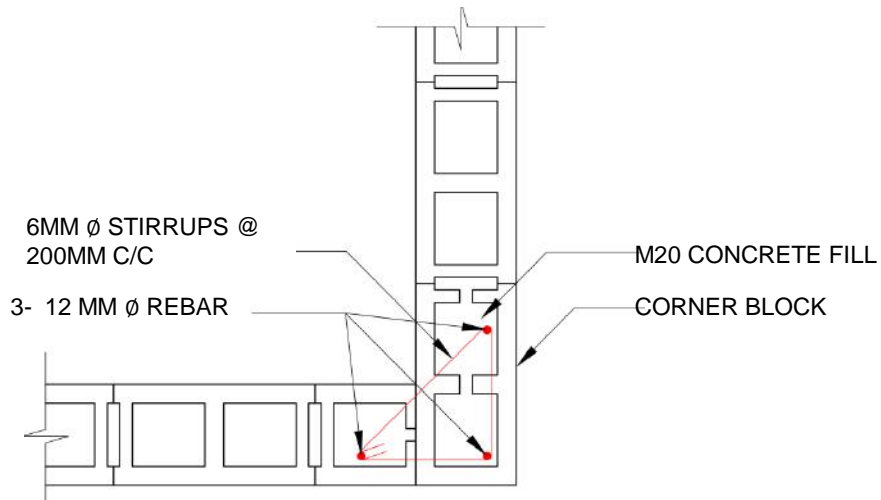

**REINFORCEMENT DETAIL AT CORNER**

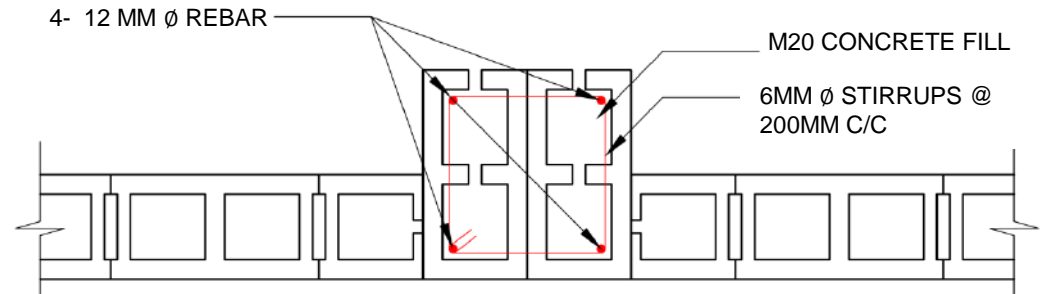

**REINFORCEMENT DETAIL AT T-JUNCTION**

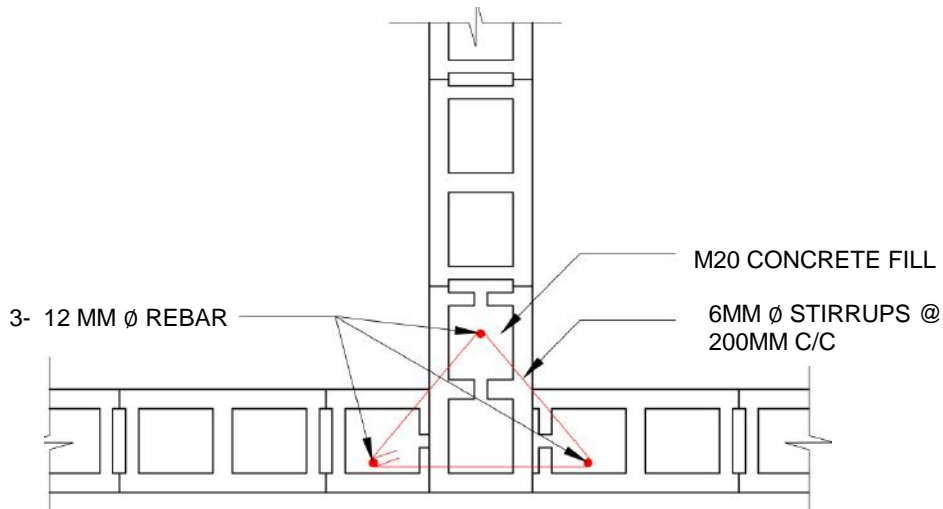

**COLUMN PROJECTION DETAIL**

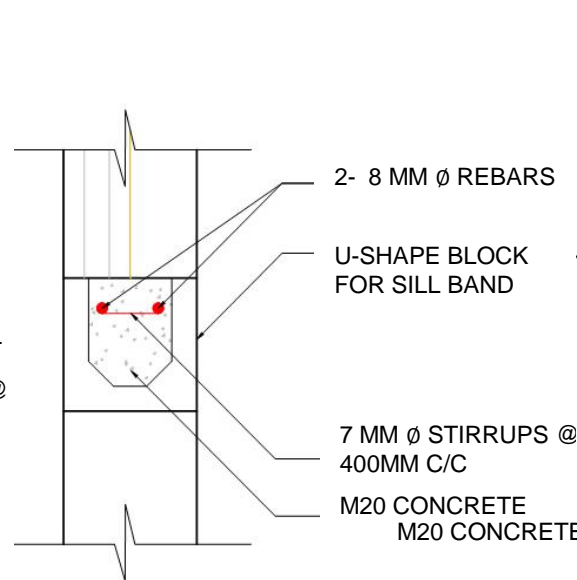

**DETAIL AT B SILL BAND**

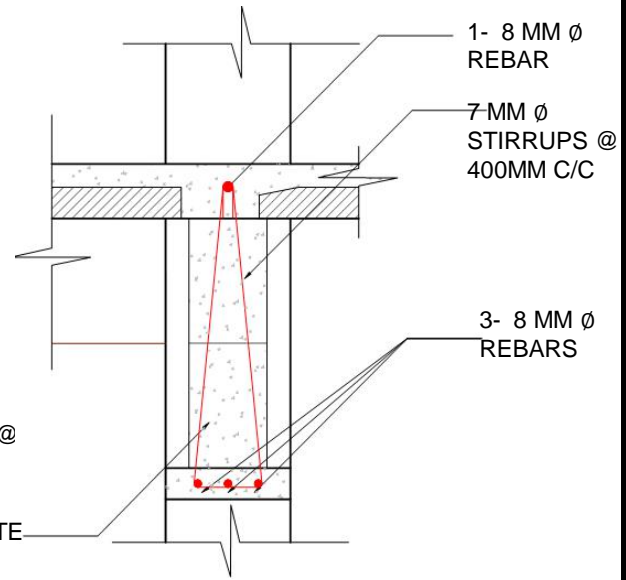

**DETAIL AT A LINTEL BEAM**



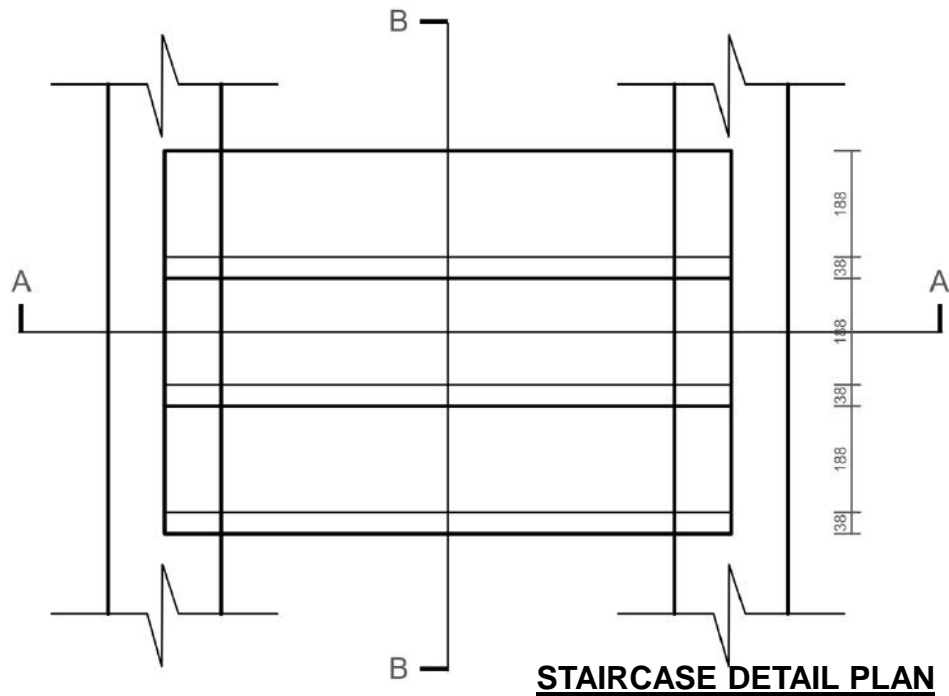

**STAIRCASE DETAIL PLAN**

5 NO - 4.75 MM  $\phi$  REBAR

3 NO - 8 MM  $\phi$  REBAR

M20 CONCRETE SLAB

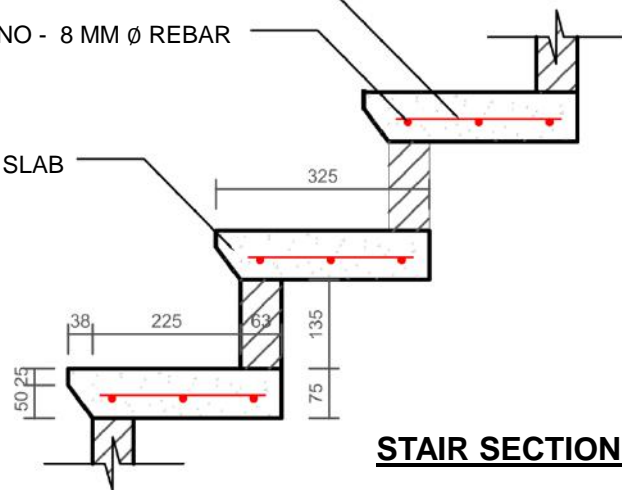

**STAIR SECTION AT B-B**

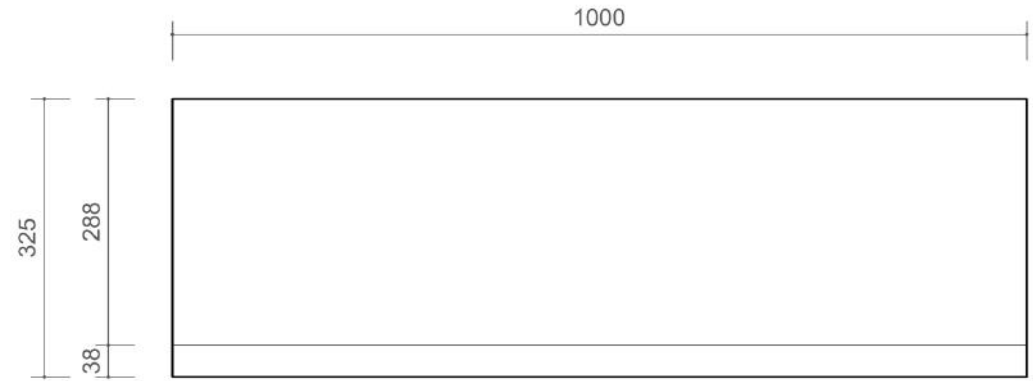

**STAIRCASE SLAB UNIT**

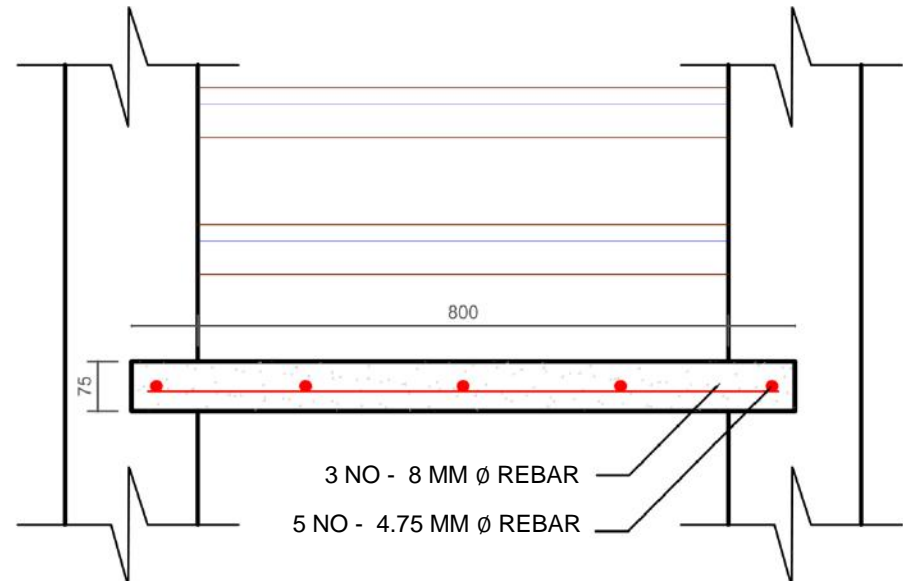

**STAIR SECTION AT A-A**

3 NO - 8 MM  $\phi$  REBAR

5 NO - 4.75 MM  $\phi$  REBAR



MINISTRY OF URBAN DEVELOPMENT  
DEPARTMENT OF URBAN DEVELOPMENT AND  
BUILDING CONSTRUCTION

HOUSING TYPE: MODEL H.C.B.-3.1

DRAWING TITLE: DETAILS

SCALE: NONE

DATE:

HCB-3.1

10/11

**TECHNICAL REQUIREMENTS**

<b>Structure System</b>	Hollow concrete block masonry with precast floor over precast beams. Vertical and Horizontal reinforcements shall be provided in strategic locations as shown in drawings.
<b>Foundation</b>	Strip Foundation of width 850 mm and depth 825 mm. Reinforcement 8 mm Ø at 200mm C/C both ways.
<b>Plinth Band</b>	Plinth beam of reinforced concrete of width 200 mm and depth 150 mm shall be provided. Main reinforcement shall be of 4 nos.10mm Ø bars with 6mm Ø stirrups at 150mm C/C.
<b>Wall System</b>	The hollow blocks shall be of size of 400x 200 x 100 mm and be of good quality and shall adhere to the Nepal Standards of block production. The mortar shall be 1: 4 (cement: sand) or richer.
<b>Sill Band</b>	A continuous reinforced concrete sill band shall be provided throughout the entire wall at the bottom level of the openings. The minimum depth of the band shall be 75mm. Main reinforcement shall be 2 nos.8mm dia. bars with 7mm Ø stirrups at 400mm C/C.
<b>Lintel Band:</b>	A continuous lintel band shall be provided throughout the entire wall at the top level of the openings. The depth of the band shall be 475mm and triangular stirrups shall connect lintel and slab. Hollow concrete blocks between lintel and slab shall be filled with 1:1.5:3 concrete.. Main reinforcement shall be 3 nos. of 10mm dia. bars with 7mm Ø triangular stirrups at 400mm c/c.
<b>Floor Beam:</b>	Precast Floor Beam with details as shown in drawing.
<b>Floor:</b>	100 mm thick reinforced concrete slab as shown in detail drawing.
<b>Roof:</b>	38 mm cast in situ concrete (1:1.5:3) over 50 mm precast slab panels and precast beam of size 125 x 200 mm..



# COMPRESSED STABILIZED EARTH BLOCK MASONRY

**C.S.E.B.-4.1**

**C.S.E.B.-4.2**

Compressed Stabilized Earth Block (**CSEB**) Technology makes use of mud as a predominant building material. The properties of soil used are improved by using stabilizers like cement. The proposed technology is very suitable for rural areas where local materials are used and their quality improved by adding small quantities of non local materials. Featured design C.S.E.B.-4.1 is a low cost, single storied two room residential units of load bearing stabilized earthen block walls with mud stabilized soil roof over bamboo rafter and purlins. Design Model C.S.E.B.-4.2 is a two storied residential units with eight rooms. Load bearing walls are made of Earthen block stabilized with chemicals.

### **MATERIAL PROPERTIES( C.S.E.B 4.1)**

Block Size: 30cm X 20cm X10cm

Min Compressive Strength on gross area CSEB: 3.5 Mpa

### **MATERIAL PROPERTIES( C.S.E.B 4.2)**

<b>Properties</b>	<b>Solid Brick</b>
Size	230*110*55 mm
28 days dry compressive strength	7.5 - 10 MPa
28 days wet compressive strength (after 24 hours immersion)	3 - 4 MPa
Apparent bulk density	2100 - 2350 kg/m <sup>3</sup>
Total Water absorption	5 - 10 %
Moisture content	< 0.03%
Dry Shrinkage	< 0.04%
Shell thickness	-

# C.S.E.B.-4.1

# C.S.E.B.-4.2



LEVEL	MATERIALS					
	Stabilized block	Cement	Sand	Reinforcing Bar	Wood	Bamboo
	No.	Bags	Cu.m.	Kg.	Cu.m.	Nos
Up to Plinth Level	1,758.0	17.0	2.3	-	-	-
Super Structure	1,500.0	8	1.4	237.3	0.2	26
Roofing	-	-	-	-	2.4	31.0
<b>TOTAL</b>	<b>3,258.0</b>	<b>25</b>	<b>3.7</b>	<b>237.3</b>	<b>2.6</b>	<b>57</b>



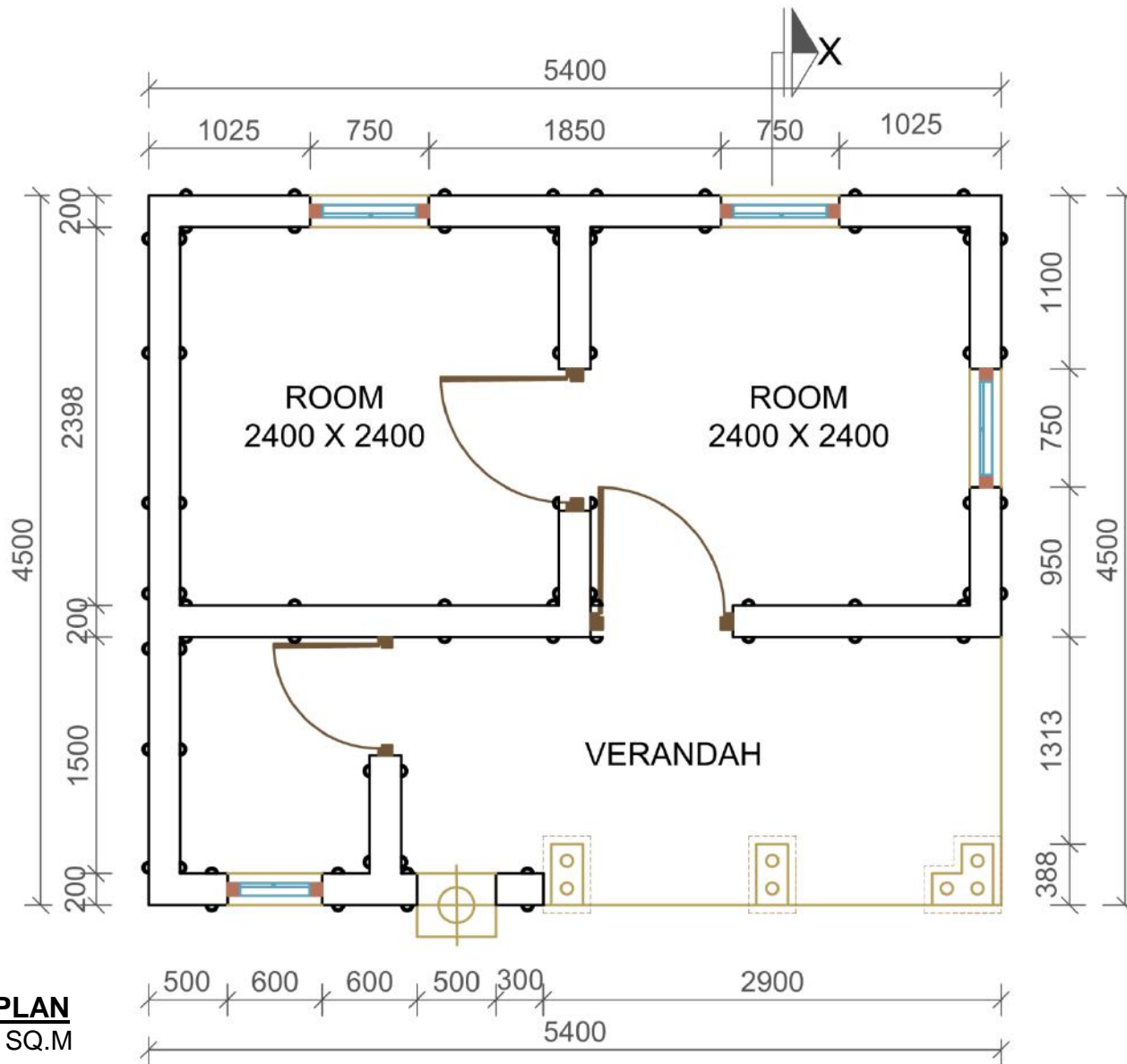

**GROUND FLOOR PLAN**  
 FLOOR AREA: 24.08 SQ.M



MINISTRY OF URBAN DEVELOPMENT  
 DEPARTMENT OF URBAN DEVELOPMENT AND  
 BUILDING CONSTRUCTION

HOUSING TYPE: CSEB-4.1

DRAWING TITLE: GROUND FLOOR PLAN

SCALE: NONE

DATE:

CSEB-4.1

2/8



# MODEL C.S.E.B-4.1, COMPRESSED STABILIZED EARTH BLOCK MASONRY

ONE STOREY

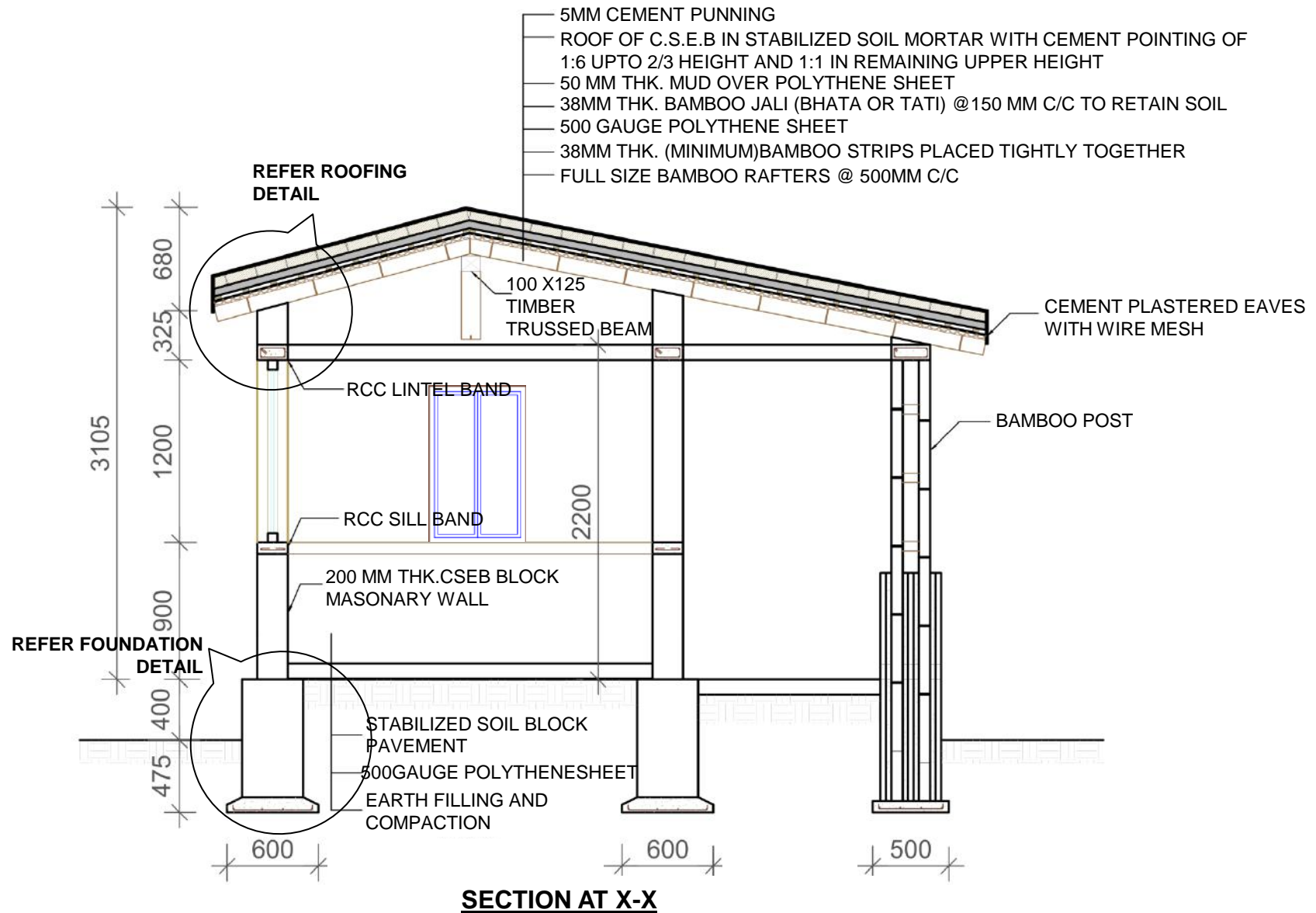

MINISTRY OF URBAN DEVELOPMENT  
DEPARTMENT OF URBAN DEVELOPMENT AND  
BUILDING CONSTRUCTION

HOUSING TYPE: CSEB-4.1

DRAWING TITLE: SECTION

SCALE: NONE

DATE:

CSEB-4.1

3/8

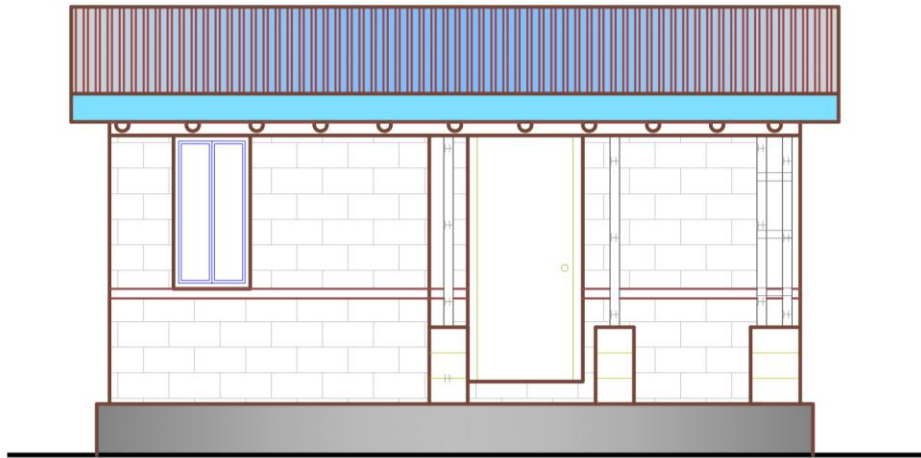

**FRONT ELEVATION**

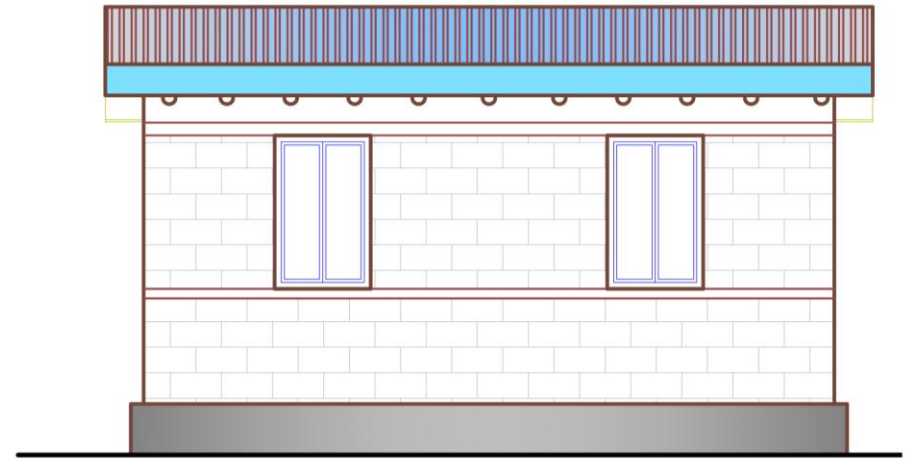

**BACK ELEVATION**

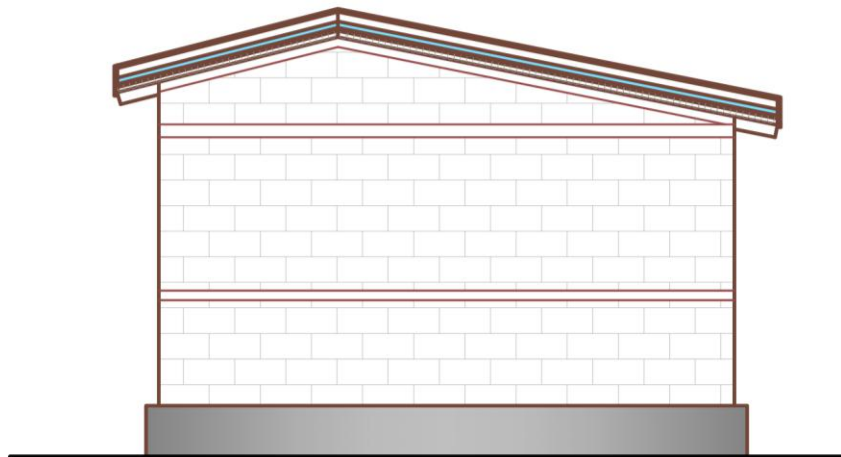

**LEFT ELEVATION**



**RIGHT ELEVATION**



MINISTRY OF URBAN DEVELOPMENT  
DEPARTMENT OF URBAN DEVELOPMENT AND  
BUILDING CONSTRUCTION

HOUSING TYPE: CSEB-4.1

DRAWING TITLE: ELEVATIONS

SCALE: NONE

DATE:

CSEB-4.1

4/8

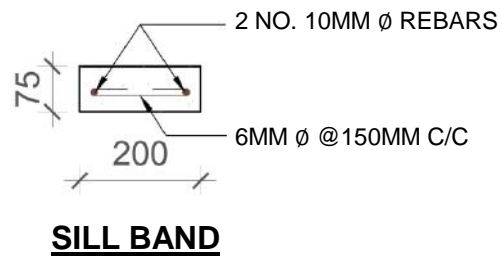
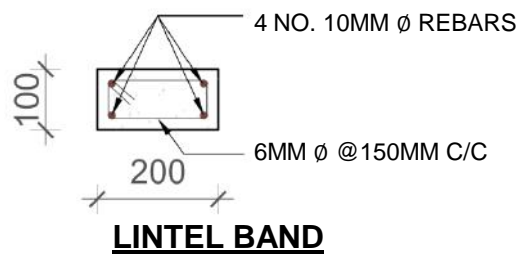
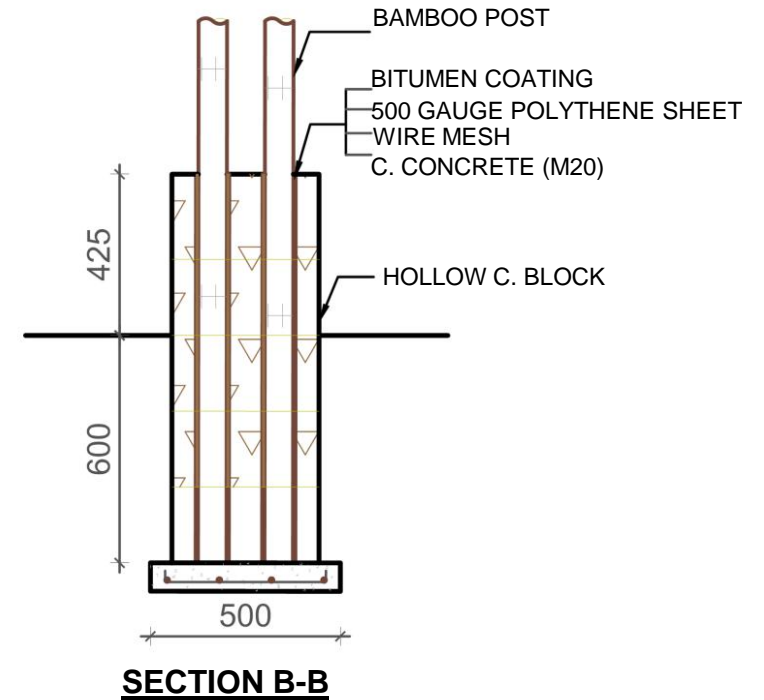
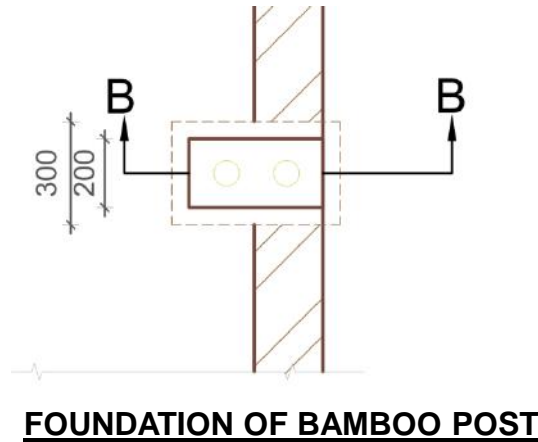
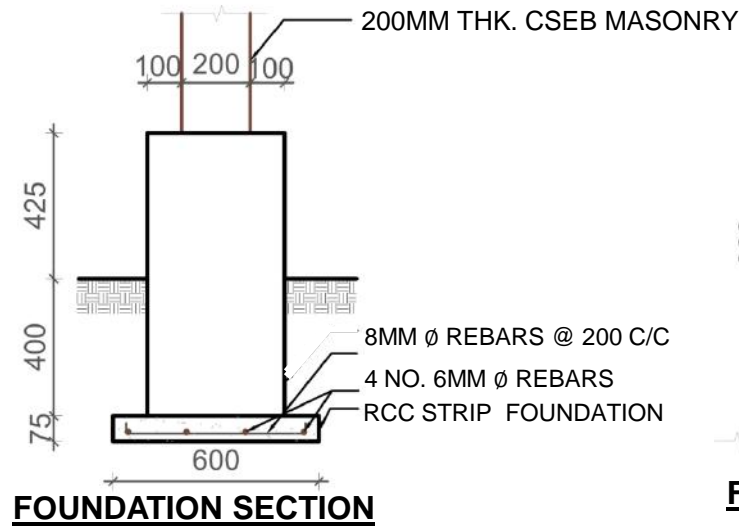

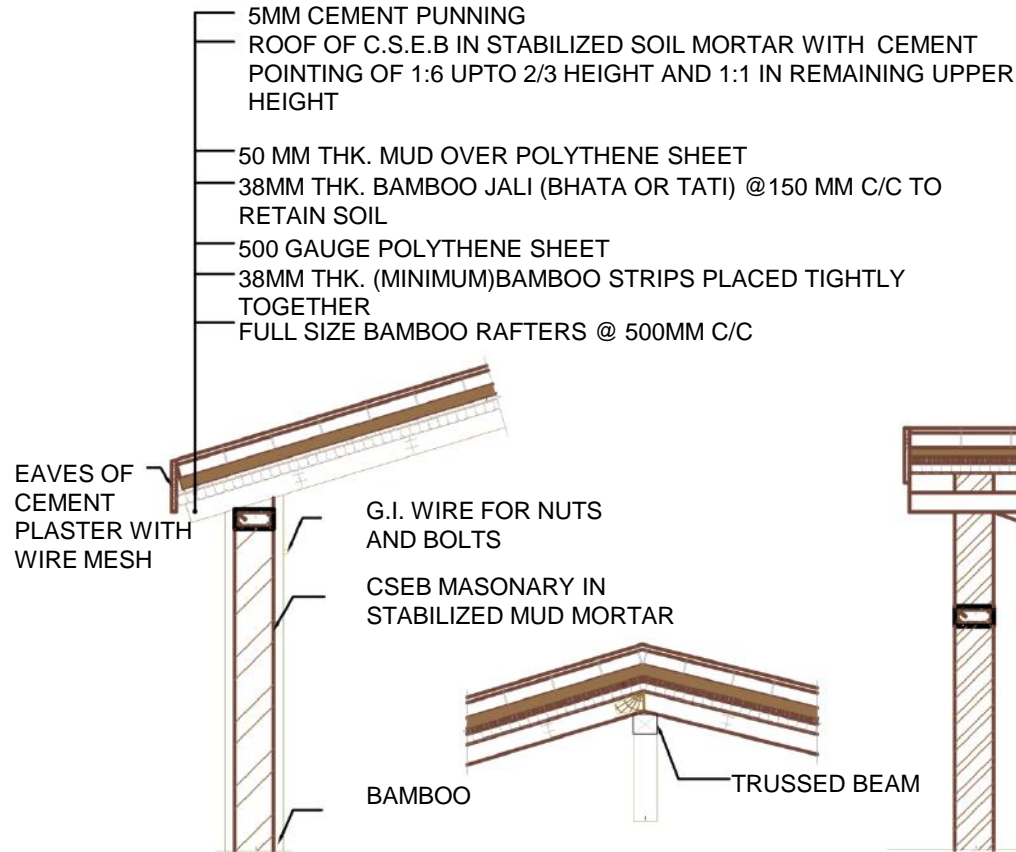

**ROOFING DETAILS**

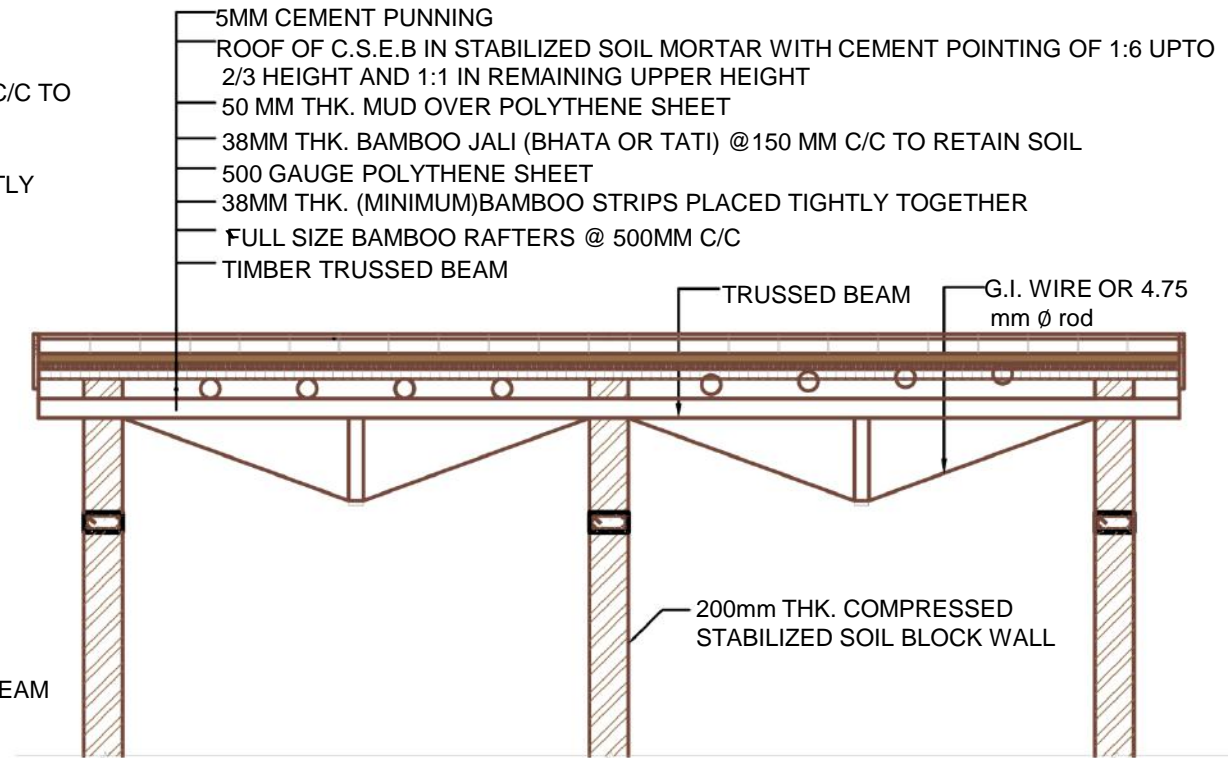

**SECTION A' - A'**



# MODEL C.S.E.B-4.1, COMPRESSED STABILIZED EARTH BLOCK MASONRY

ONE STOREY

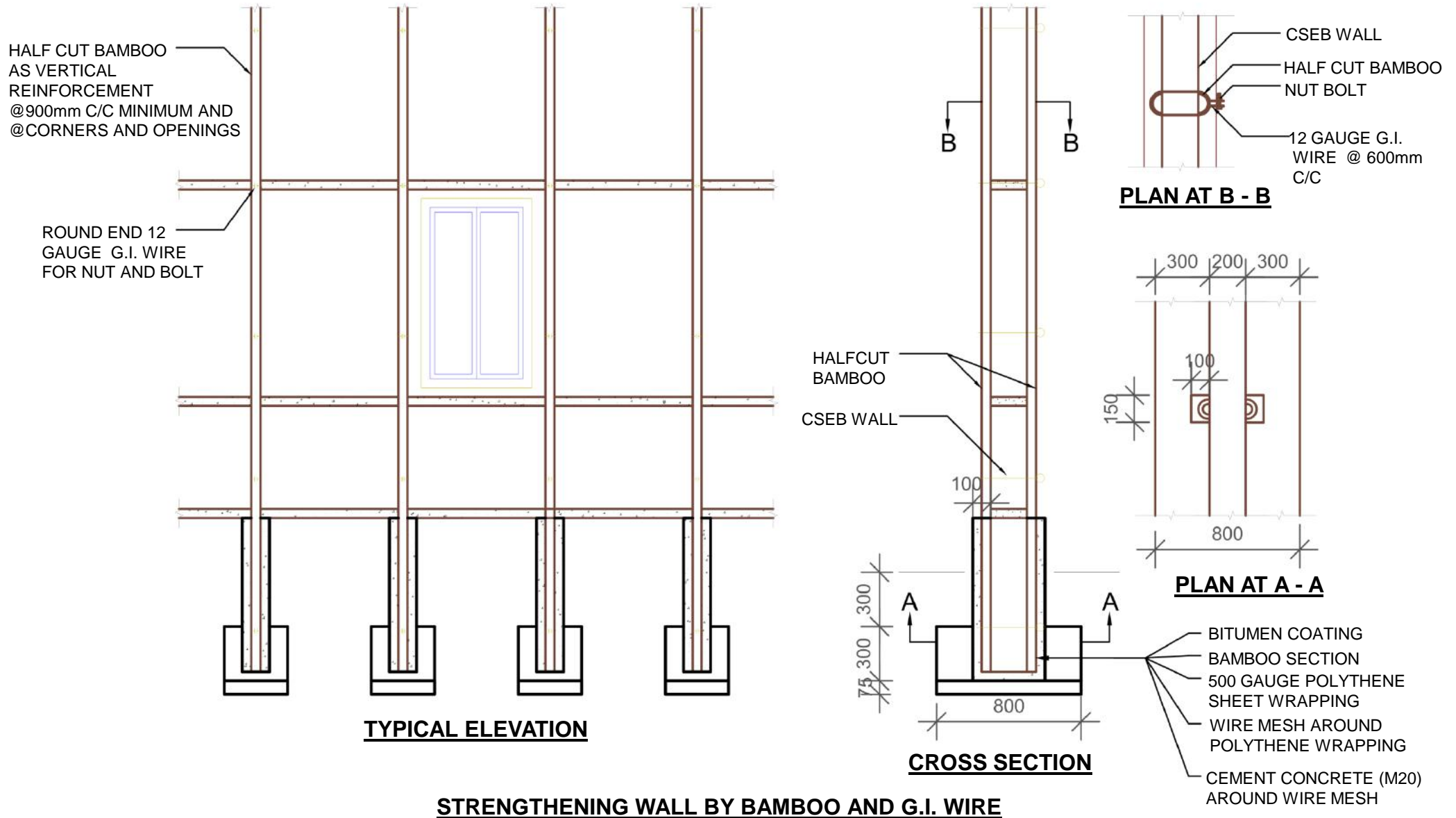

MINISTRY OF URBAN DEVELOPMENT  
DEPARTMENT OF URBAN DEVELOPMENT AND  
BUILDING CONSTRUCTION

HOUSING TYPE: CSEB-4.1

DRAWING TITLE: DETAILS

SCALE: NONE

DATE:

CSEB-4.1

7/8

**TECHNICAL REQUIREMENTS**

<b>Structure System</b>	Compressed Stabilized Earth block masonry in mud mortar with stabilized soil roof.
<b>Foundation</b>	Strip Foundation of Compressed stabilized Earth Block Masonry of width 400 mm and depth 400 mm over 600 x 75 mm RCC strip foundation.
<b>Plinth Band</b>	Plinth Beam of reinforced concrete of width 200 mm and depth 100mm shall be provided. Main reinforcement 4 nos.10mm Ø bars with 6mm Ø stirrups at 150mm C/C
<b>Wall System</b>	Masonry shall be of cement stabilized earth block of size 300x 200 x 100 mm size in mud mortar.
<b>Sill Band</b>	A continuous reinforced concrete sill band shall be provided throughout the entire wall at the bottom level of the openings. The minimum depth of the band shall be 75mm. Main reinforcement shall be 2 nos.10mm dia. bars with 6mm Ø stirrups at 150mm C/C.
<b>Lintel Band:</b>	A continuous reinforced concrete Lintel band shall be provided throughout the entire wall at the top level of the openings. The minimum depth of the band shall be 100 mm. Main reinforcement shall be 4 nos.10mm dia. bars with 6mm Ø stirrups at 150mm C/C.
<b>Roof:</b>	5mm cement punning over stabilized soil plaster on 50 mm thick mud roof on bamboo truss.





LEVEL	MATERIALS								
	CS Blocks	Cement	Sand	Aggregate	Reinforcing Bar	CGI Sheet	GI Sheet	Wood	MS Black Pipe
	No.	Bags	Cu.m.	Cu.m.	Kg.	Bundle	Sq.m.	Cu.m.	Kg.
Up to Plinth Level	4,040.0	43	3.9	7.4	1,410.1			-	-
Super Structure	6,651.0	115.0	6.1	12.4				1.7	
Roofing	-	-	-	-	-	8.2	9.8	-	1,408.3
<b>TOTAL</b>	<b>10691</b>	<b>158</b>	<b>10.0</b>	<b>19.8</b>	<b>1,410.1</b>	<b>8.2</b>	<b>9.8</b>	<b>1.7</b>	<b>1,408.3</b>



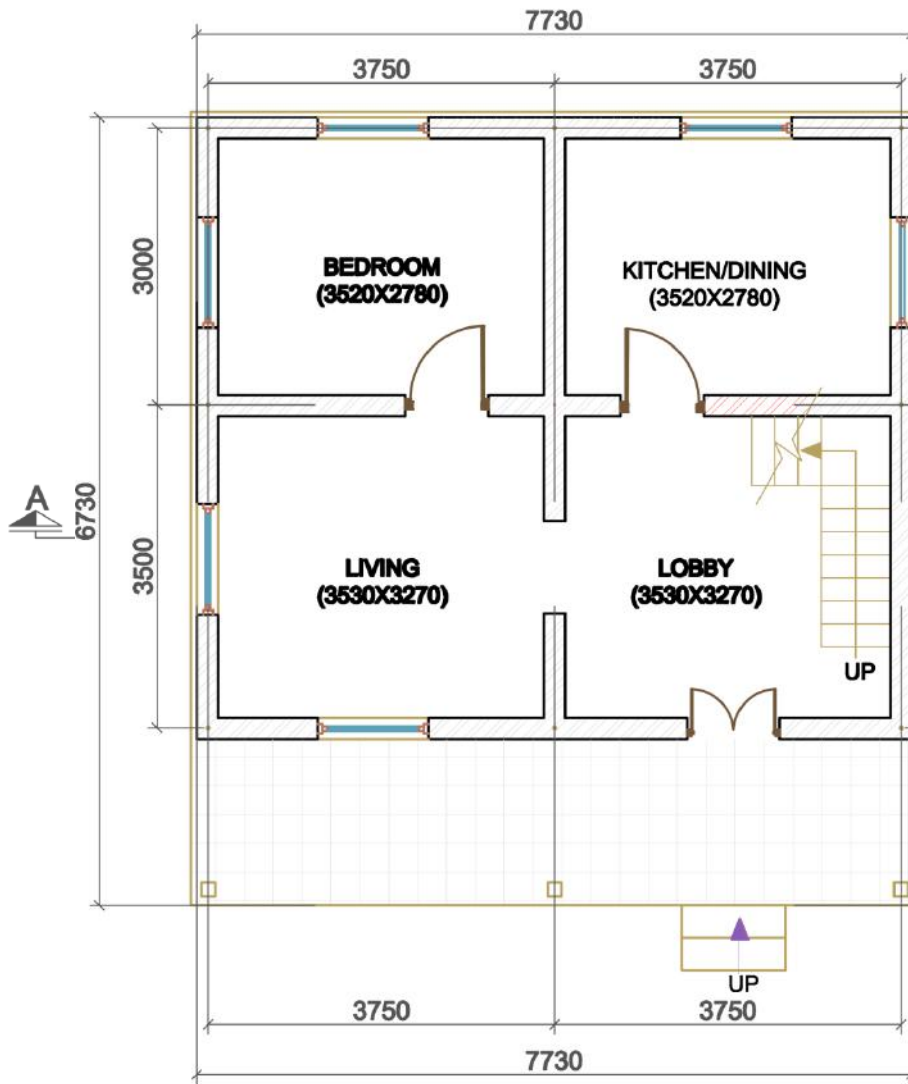

**GROUND FLOOR PLAN**  
FLOOR AREA: 52.02SQ.M

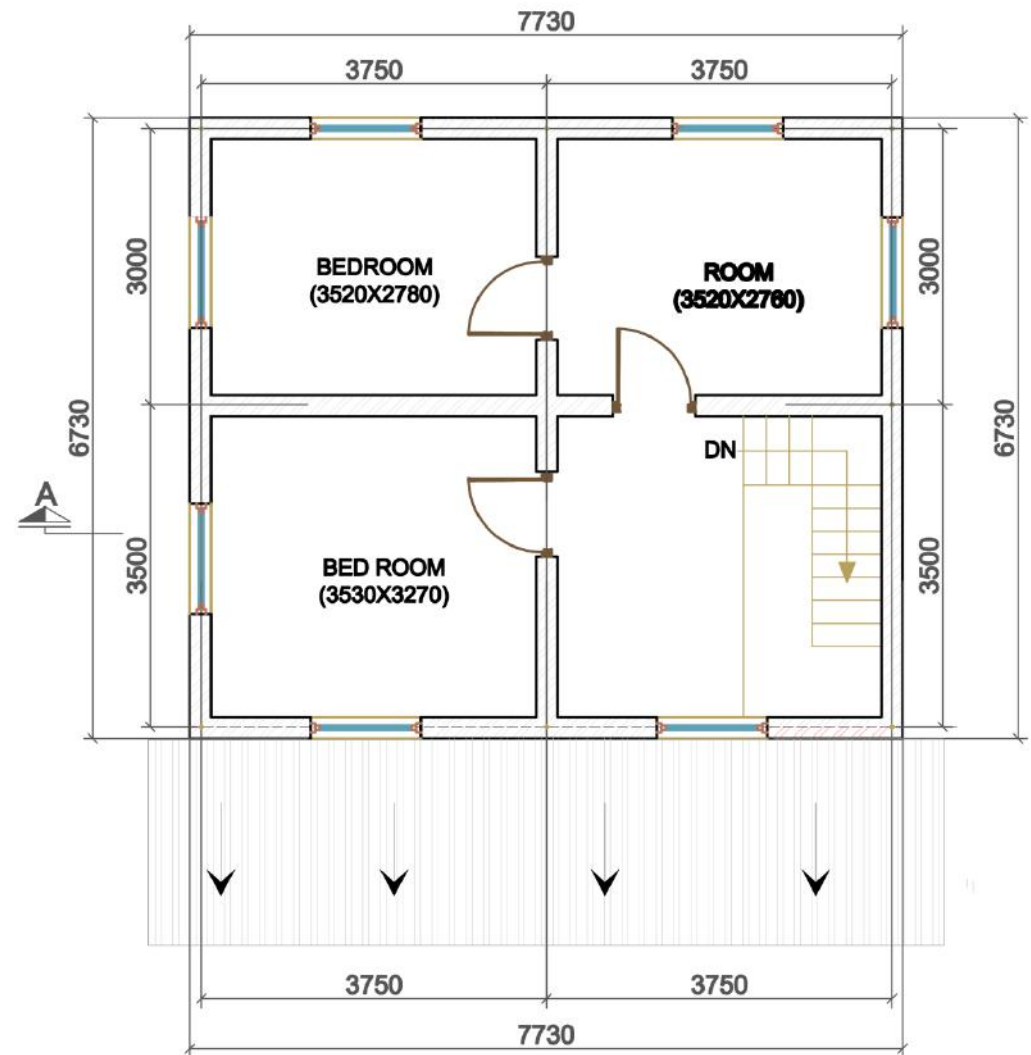

**FIRST FLOOR PLAN**  
FLOOR AREA: 52.02SQ.M



MINISTRY OF URBAN DEVELOPMENT  
DEPARTMENT OF URBAN DEVELOPMENT AND  
BUILDING CONSTRUCTION

HOUSING TYPE: CSEB-4.2

DRAWING TITLE: FLOOR PLANS

SCALE: NONE

DATE:

CSEB-4.2

2/9



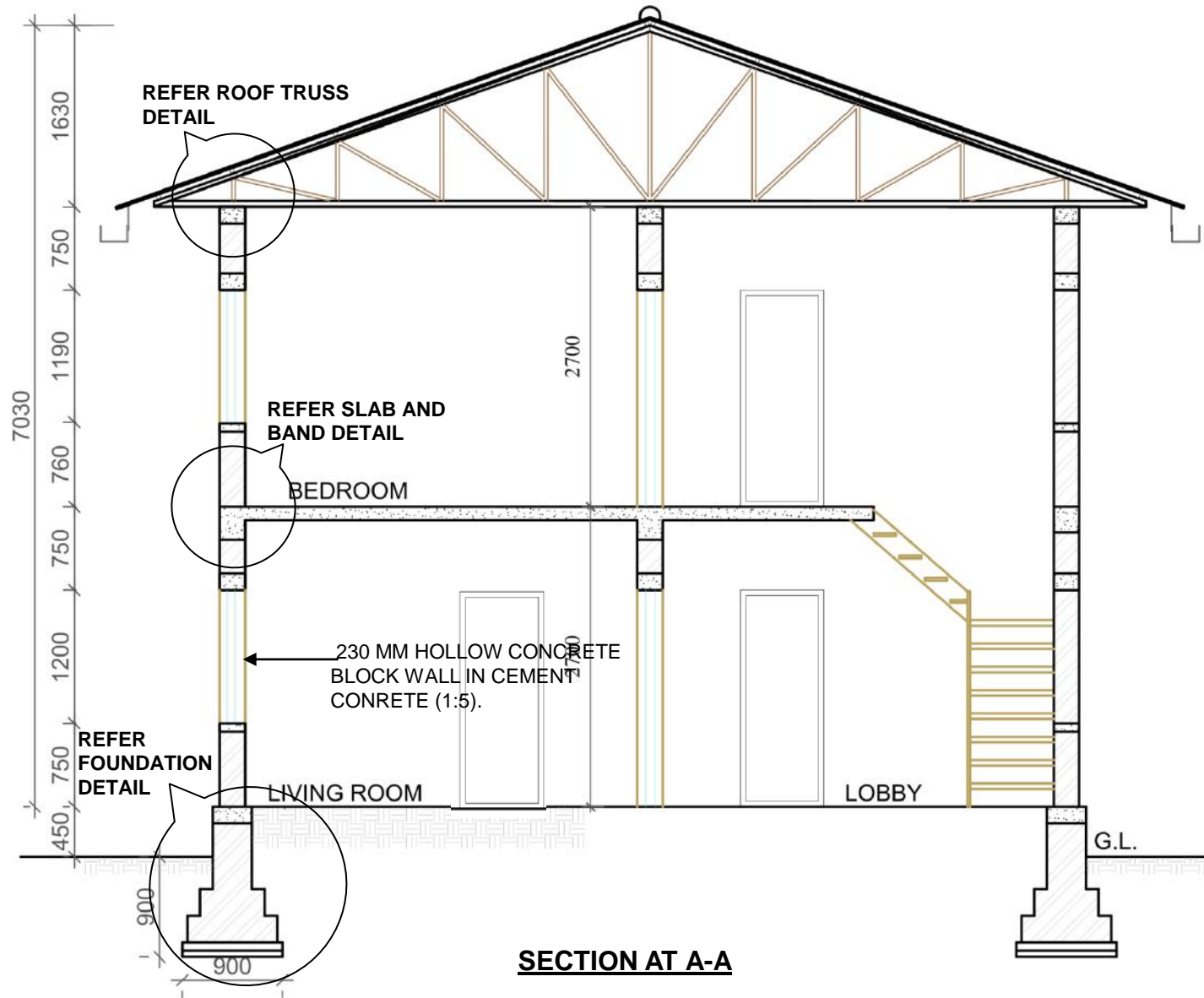



**FRONT ELEVATION**



**BACK ELEVATION**

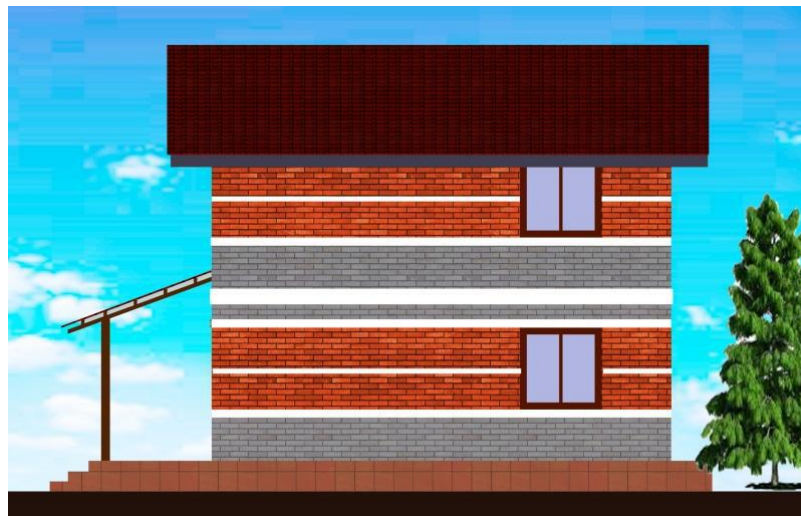

**SIDE ELEVATION**



**SIDE ELEVATION**



**MINISTRY OF URBAN DEVELOPMENT  
DEPARTMENT OF URBAN DEVELOPMENT AND  
BUILDING CONSTRUCTION**

**HOUSING TYPE: CSEB-4.2**

**DRAWING TITLE: ELEVATION**

**SCALE: NONE**

**DATE:**

**CSEB-4.2**

**4/9**

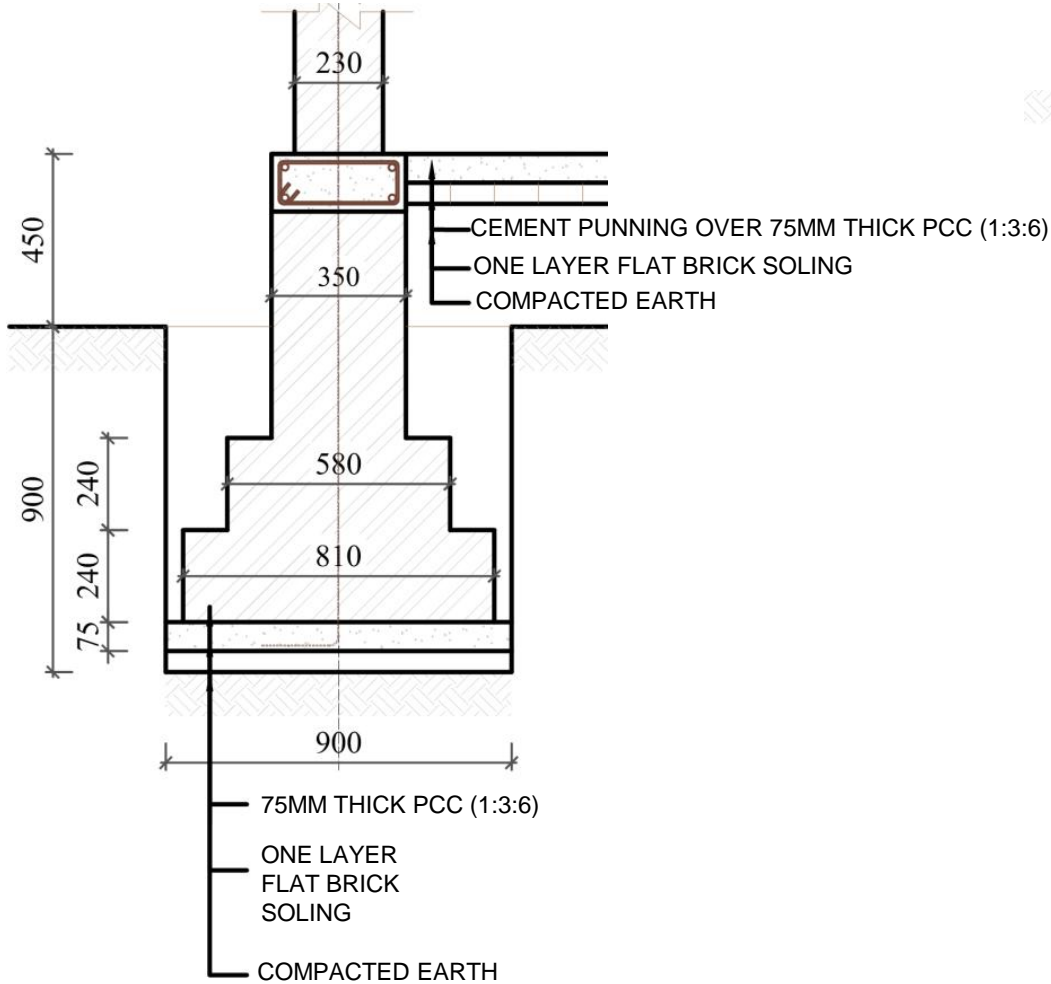

**FOUNDATION SECTION**

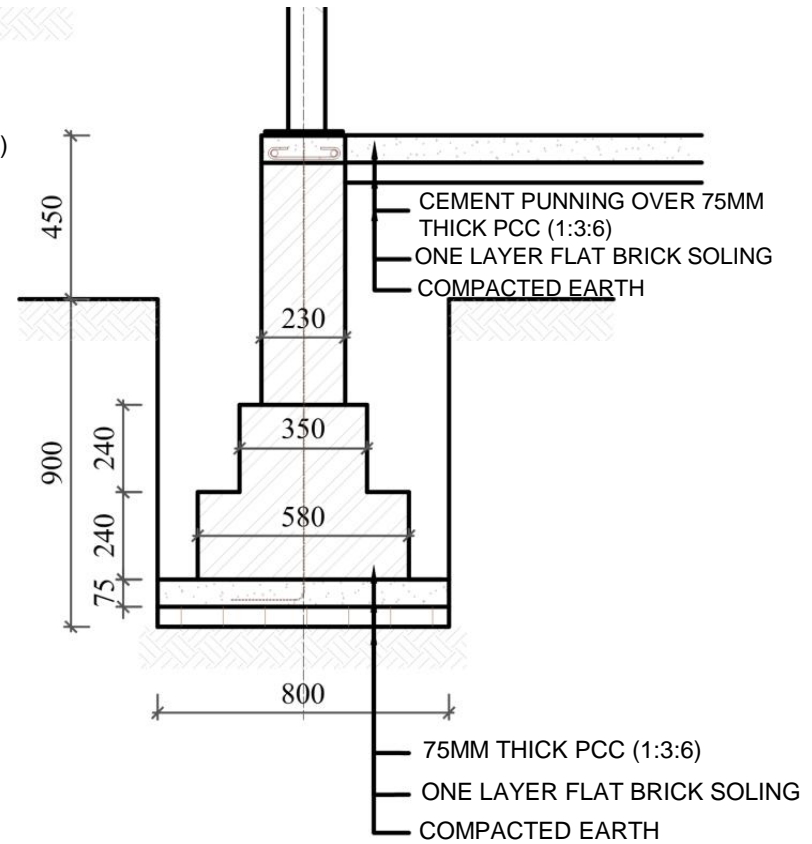

**FOUNDATION DETAIL  
(FOR VERANDAH)**



# MODEL C.S.E.B-4.2, COMPRESSED STABILIZED EARTH BLOCK MASONRY

TWO STOREY

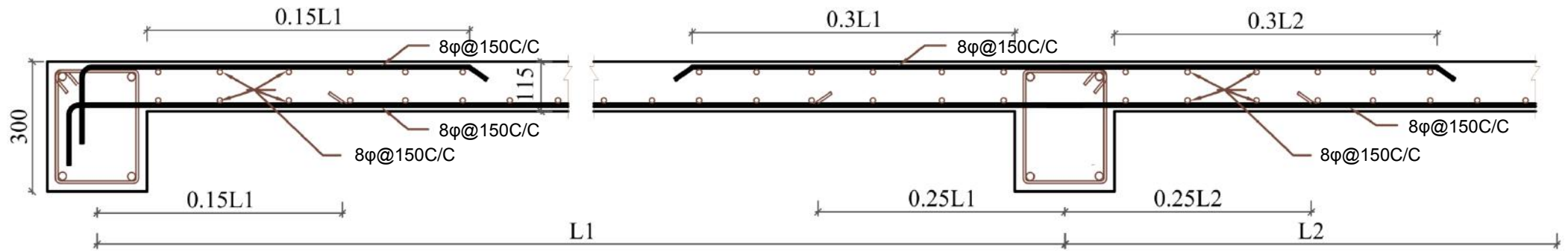

**FLOOR SLAB**

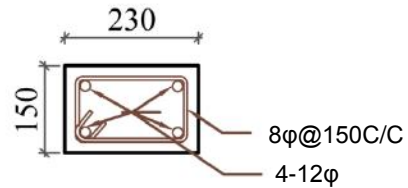

**ROOF BAND**

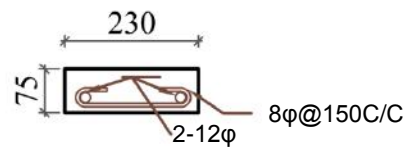

**SILL BAND**

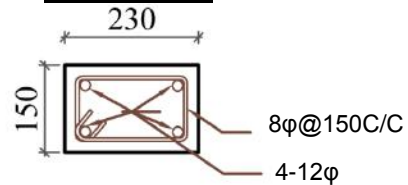

**LINTEL BAND**

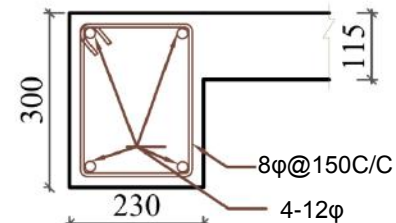

**FLOOR BEAM**

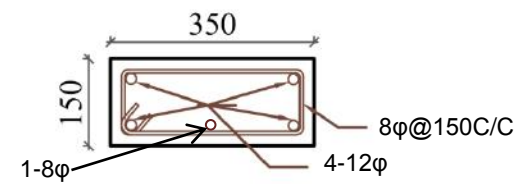

**PLINTH BAND**



MINISTRY OF URBAN DEVELOPMENT  
DEPARTMENT OF URBAN DEVELOPMENT AND  
BUILDING CONSTRUCTION

HOUSING TYPE: CSEB-4.2

DRAWING TITLE: DETAILS

SCALE: NONE

DATE:

CSEB-4.2

6/9

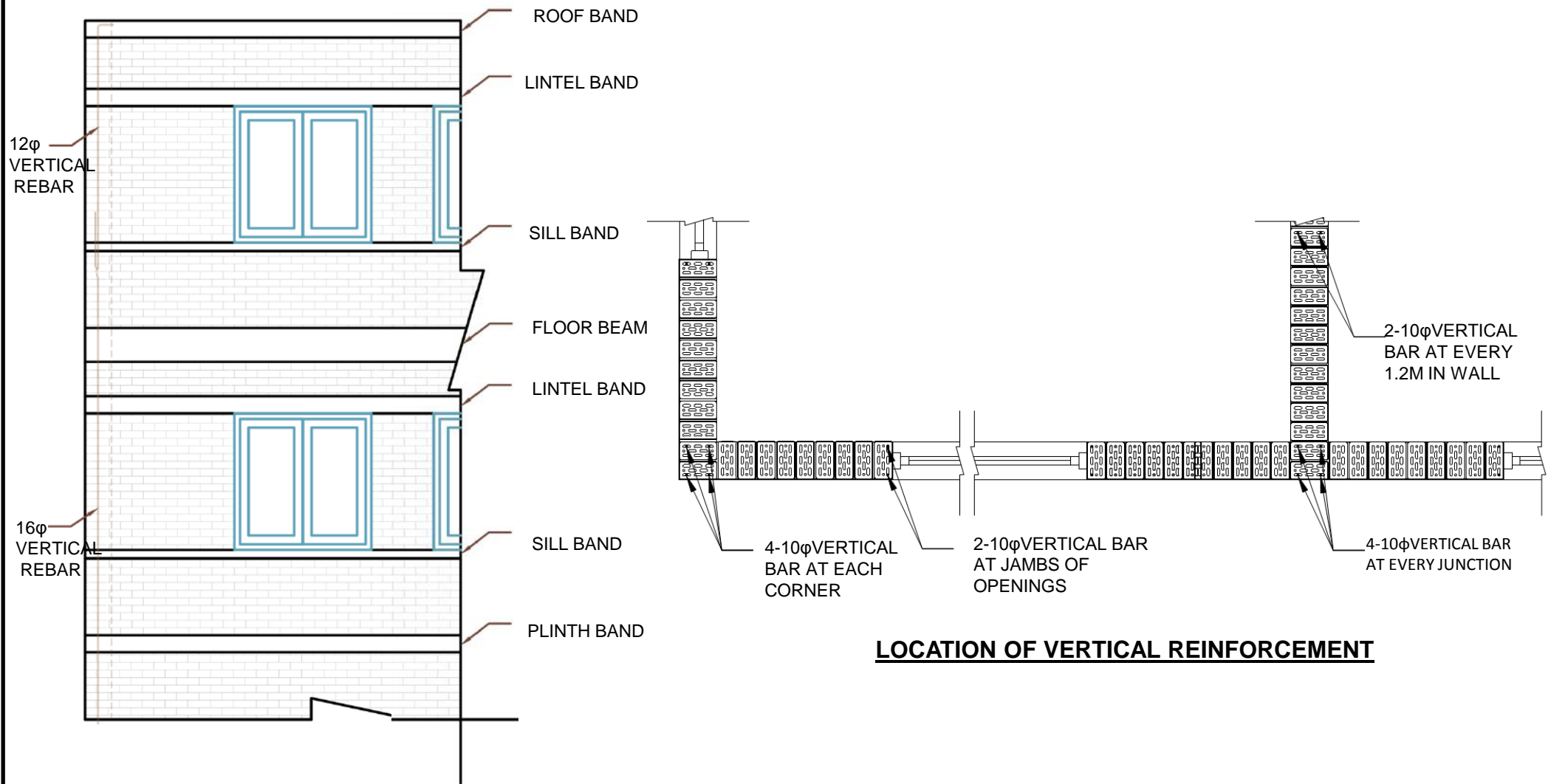

**LOCATION OF VERTICAL REINFORCEMENT**

**LAYOUT OF HORIZONTAL AND VERTICAL REINFORCEMENT**



MINISTRY OF URBAN DEVELOPMENT  
DEPARTMENT OF URBAN DEVELOPMENT AND  
BUILDING CONSTRUCTION

HOUSING TYPE: CSEB-4.2

DRAWING TITLE: REINFORCEMENT DETAILS

SCALE: NONE

DATE:

CSEB-4.2

7/9

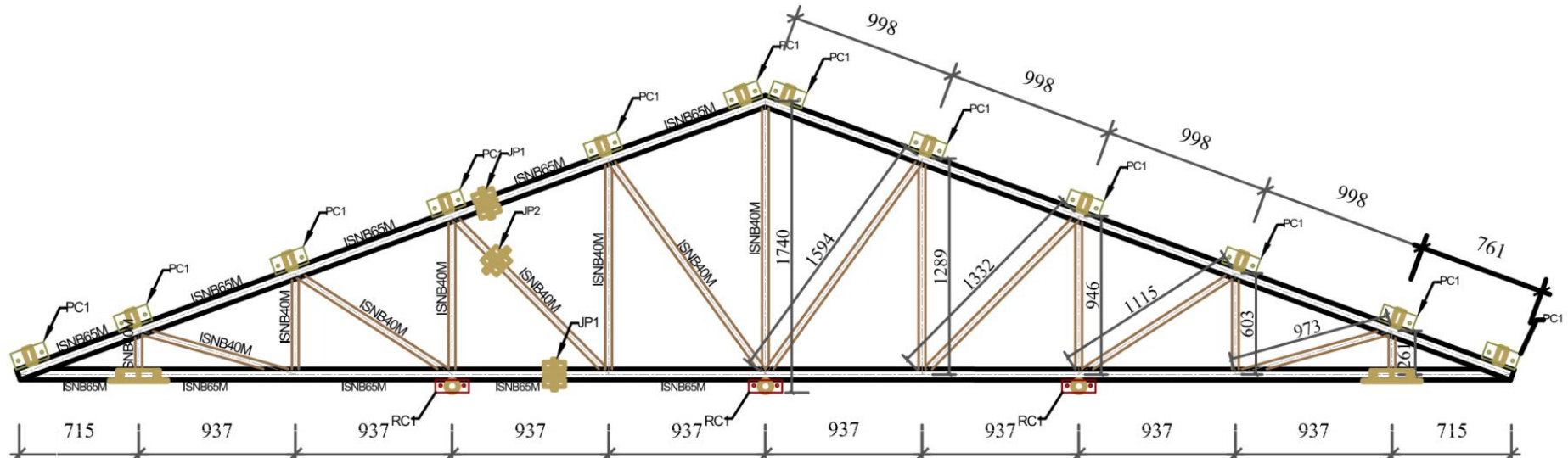

**ROOF TRUSS DETAILS**

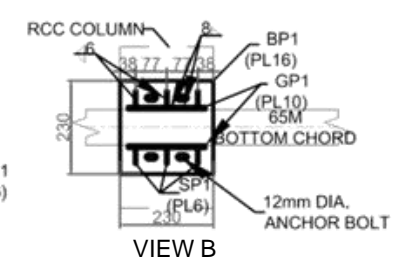
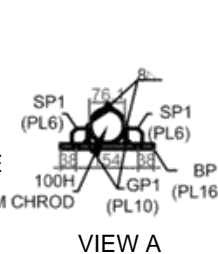
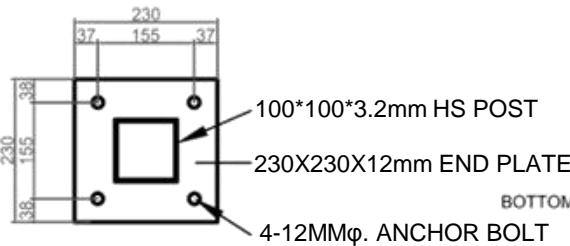
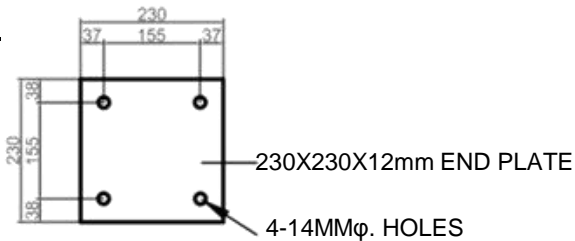

**VERANDAH POST END PLATE DETAILS**

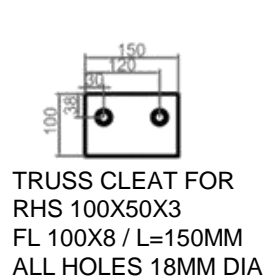
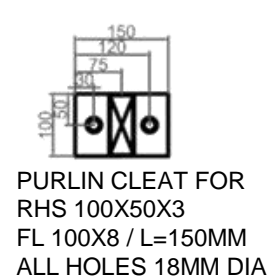
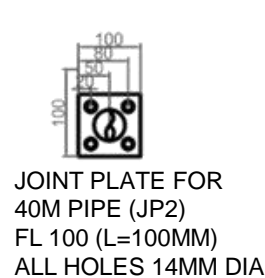
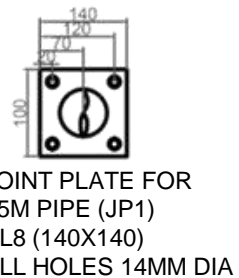

**VERANDAH POST END PLATE DETAILS**

**BASE CONNECTION DETAILS**

**JOINT PLATE DETAILS (JP1/JP2)**

**PURLIN CLEAT DETAILS (PC1)**

**RUNNER CLEAT DETAILS (RC1)**



MINISTRY OF URBAN DEVELOPMENT  
DEPARTMENT OF URBAN DEVELOPMENT AND BUILDING CONSTRUCTION

HOUSING TYPE: CSEB-4.2  
DRAWING TITLE: ROOF DETAILS

SCALE: NONE  
DATE:

CSEB-4.2  
8/9

**TECHNICAL REQUIREMENTS**

<b>Structure System</b>	Chemically stabilized earth block (solid/hollow) masonry in cement sand mortar with CGI sheet roof over metal truss. Vertical and Horizontal reinforcements shall be provided in strategic locations as shown in the drawing.
<b>Foundation</b>	Chemically compressed stabilized block masonry strip foundation of width 900 mm and depth 900 mm as shown in detail.
<b>Plinth Band</b>	Plinth Beam of reinforced cement concrete (1:1.5:3) of width 350 mm and depth 150mm shall be provided. Main reinforcement 4 nos.12mm Ø bars with 8mm Ø stirrups at 150mm C/C.
<b>Wall System</b>	The chemically compressed stabilized Earth block shall be of size of 230x 100 x 55mm size and stabilized with flat plug resin chemical. Mortar shall be cement sand in 1:5 ratio or richer.
<b>Sill Band</b>	A continuous reinforced concrete sill band shall be provided throughout the entire wall at the bottom level of the openings. The minimum depth of the band shall be 75mm. Main reinforcement shall be 2 nos.12mm dia. bars with 8mm Ø stirrups at 150mm C/C.
<b>Lintel Band:</b>	A continuous reinforced concrete lintel band shall be provided throughout the entire wall at the top level of the openings. The minimum depth of the band shall be 150mm. Main reinforcement shall be 4 nos.12mm dia. bars with 8mm Ø stirrups at 150mm C/C.
<b>Floor:</b>	130 mm thick RCC (1:1.5:3) floor over beam of width 230 mm and depth 300mm (115mm slab thickness).
<b>Roof:</b>	CGI sheet roofing over metal truss as shown in the drawing.



**RANDOM RUBBLE MASONRY IN MUD  
MORTAR WITH GI WIRE CONTAINMENT**

**R.R.M-5.1**

**R.R.M-5.2**



This technology is an improvement on random rubble masonry structure by introduction of GI containment wires. Vertical GI Containment wires are provided on two faces of a masonry wall to prevent flexural failure. The reinforcement on the two faces are connected by ties going through walls to prevent delamination of the walls. The proposed design makes minimal changes in local construction system.

Featured design R.R.M. 5.1 is a one storied two room unit with CGI sheet roofing. Featured design R.R.M. 5.2 is a two storied four room unit with CGI sheet roofing. Basic materials like stone and mud for walls, corrugated galvanized iron sheets on timber rafter/purlins for roof and mud flooring on timber deck for intermediate floors are proposed similar to common houses in the hills of Nepal. The basic shape and size of the building comply Nepal National Building Code, NBC 203 : 1994, Guidelines for earthquake resistant building construction: low strength masonry.

# R.R.M-5.1

# R.R.M-5.2



LEVEL	MATERIALS								
	Stone	Weld wire mesh	Sand	Mud	CGI Sheet	GI Sheet	Wood	4mm GI wire	2 mm GI Wire
	Cu.m.	Sq.m	Cu.m.	Cu.m.	Bundle	Sq.m.	Cu.m.	Kg	Kg
Up to Plinth Level	16.1	10.4	1.3	7.4			-	6.0	14.0
Super Structure	28.8	40.7	-	11.0			0.5	19.0	44.0
Roofing	-	-	-	-	4.1	9.1	5.6	-	4.0
<b>TOTAL</b>	<b>44.9</b>	<b>51.1</b>	<b>1.3</b>	<b>18.4</b>	<b>4.1</b>	<b>9.1</b>	<b>6.1</b>	<b>25.0</b>	<b>62.0</b>



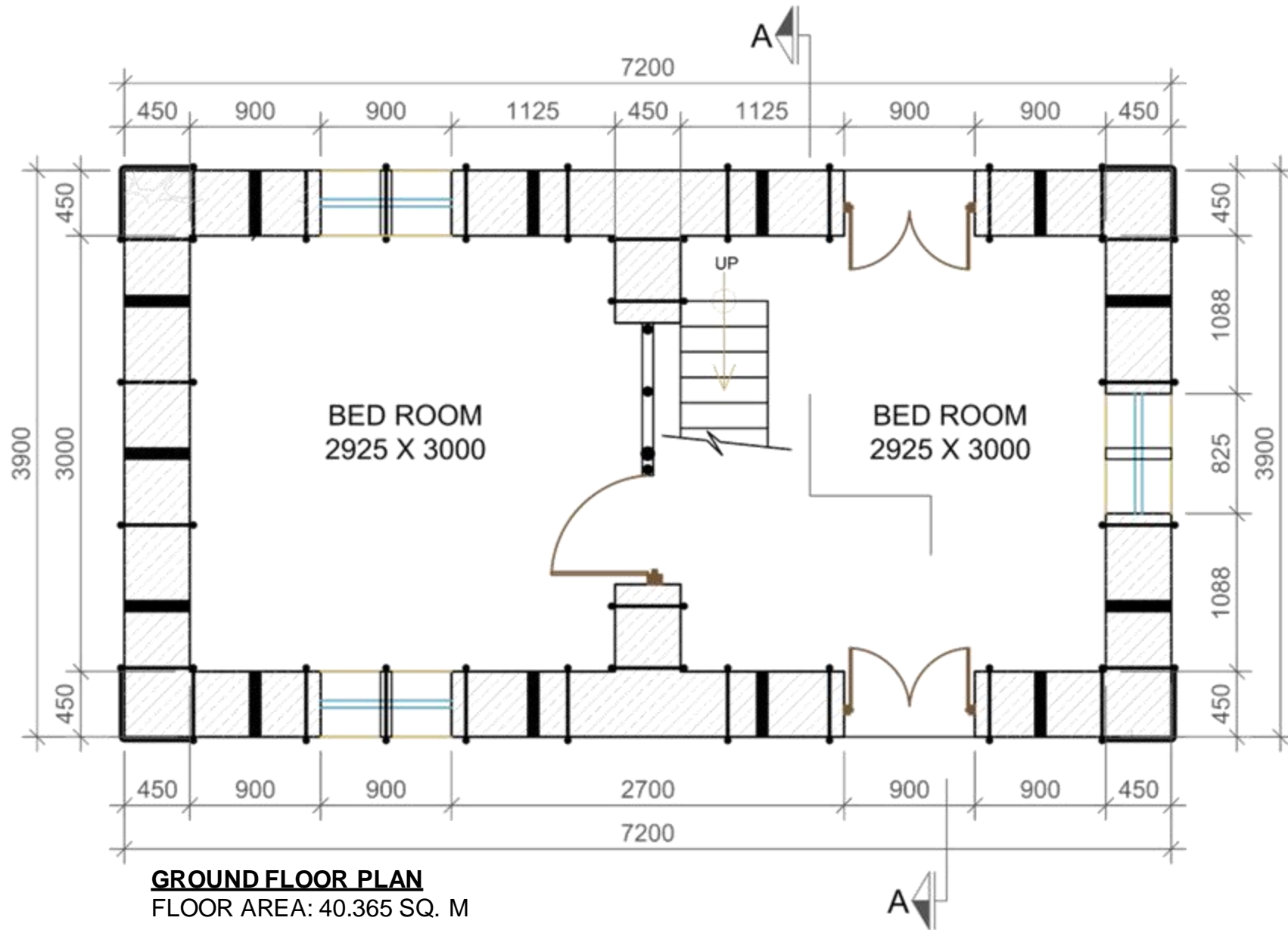

MINISTRY OF URBAN DEVELOPMENT  
 DEPARTMENT OF URBAN DEVELOPMENT AND  
 BUILDING CONSTRUCTION

HOUSING TYPE: R.R.M.-5.1

DRAWING TITLE: FLOOR PLAN

SCALE: NONE

DATE:

R.R.M-5

2/5

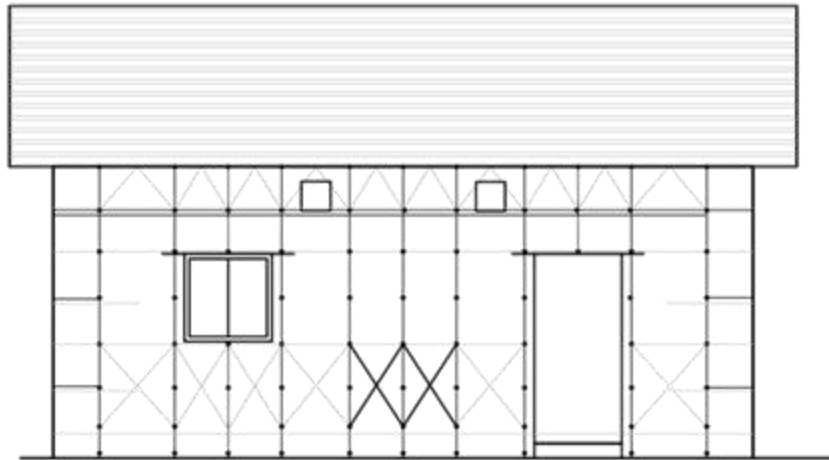

**FRONT SIDE ELEVATION**

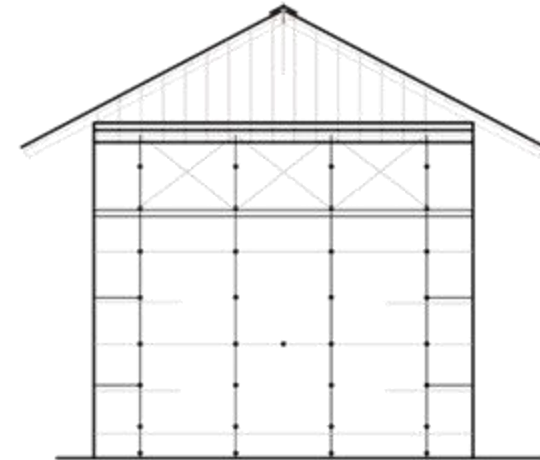

**LEFT SIDE ELEVATION**

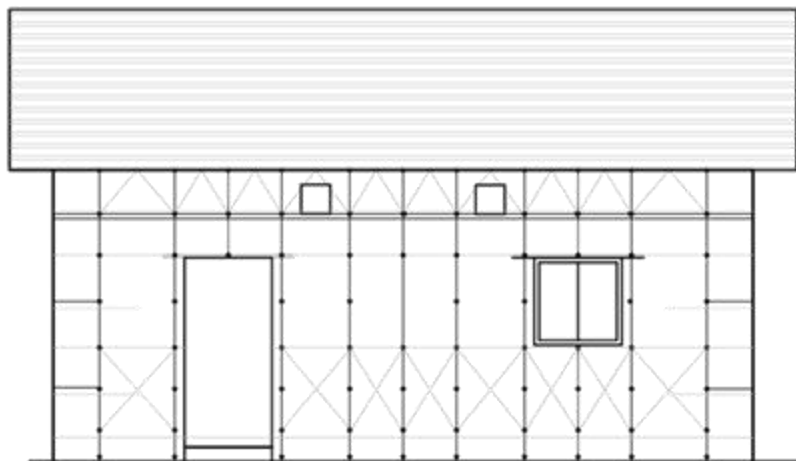

**BACK SIDE ELEVATION**

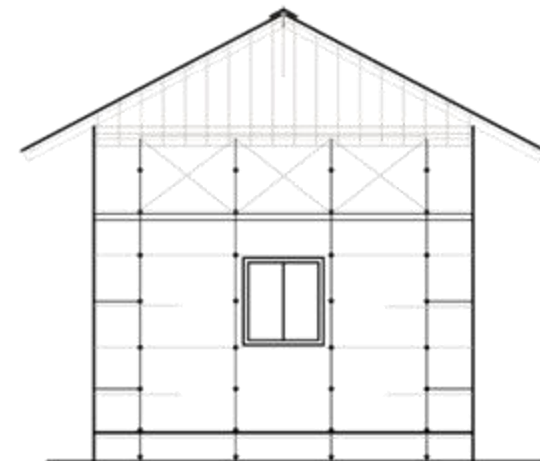

**RIGHT SIDE ELEVATION**



# MODEL R.R.M-5.1, RANDOM RUBBLE MASONRY IN MUD MORTAR

ONE STOREY

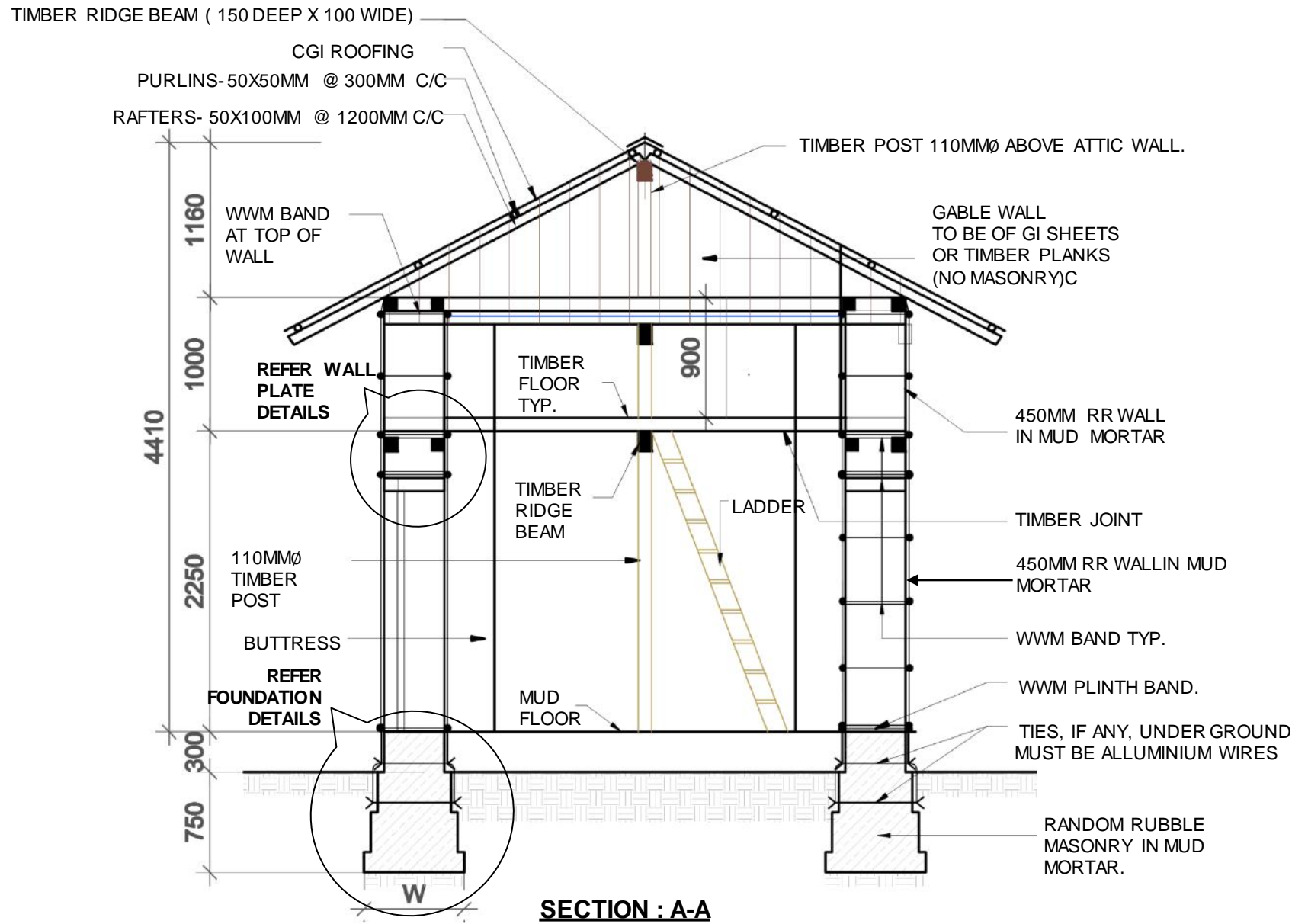

MINISTRY OF URBAN DEVELOPMENT  
DEPARTMENT OF URBAN DEVELOPMENT AND  
BUILDING CONSTRUCTION

HOUSING TYPE: R.R.M.-5.1

DRAWING TITLE: SECTION

SCALE: NONE

DATE:

R.R.M-5

4/5

**TECHNICAL REQUIREMENTS**

<b>Structure System</b>	Stone Masonry wall in mud mortar with Vertical GI Containment wires shall be provided on two faces of a masonry wall. The GI containment wires on the two faces shall be connected by ties going through walls
<b>Foundation</b>	Strip Foundation of stone masonry in mud mortar of size 750 x 750 mm as shown in detail.
<b>Plinth Band</b>	Red oxide coated or GI Weld Wire mesh (WWM) strap of 350 mm width with wire spacing of 31x 31 mm plus 2 nos. 4 mm GI wires laid in mud mortar. Diagonal WWM strap shall be provided for stronger corner connection securely tied to other WWM.
<b>Wall System</b>	Random rubble masonry in mud mortar with 4 mm vertical GI wire cross linked with 2 nos. 14 gauge (2mm) galvanized iron wires placed at 450mm C/C.
<b>Sill Band</b>	Sill band shall be of weld wire mess or wooden band as shown in detail drawing.
<b>Lintel Band:</b>	Lintel band shall be of weld wire mess or wooden band as shown in detail drawing.
<b>Floor:</b>	Mud/timber floor over timber joist (Refer drawing).
<b>Wall Plate:</b>	Wall plate shall be timber section of 100mm X 100mm placed above WWM and connected with wall (refer detail drawing)
<b>Roof:</b>	Lightweight roof of corrugated iron sheet over wooden truss. All joints in the truss shall be properly connected as shown in the drawing. All trusses shall be properly cross tied as shown in the drawing.





LEVEL	MATERIALS								
	Stone	Weld wire mesh	Sand	Mud	CGI Sheet	GI Sheet	Wood	4mm GI wire	2 mm GI Wire
	Cu.m.	Sq.m	Cu.m.	Cu.m.	Bundle	Sq.m.	Cu.m.	Kg	Kg
<b>Up to Plinth Level</b>	16.1	10.4	1.3	7.4			-	6.0	14.0
<b>Super Structure</b>	49.3	71.9	-	18.8			0.9	28.0	66.0
<b>Roofing</b>	-	-	-	-	4.1	9.1	6.6	-	4.0
<b>TOTAL</b>	<b>65.4</b>	<b>82.3</b>	<b>1.3</b>	<b>26.3</b>	<b>4.1</b>	<b>9.1</b>	<b>7.5</b>	<b>34.0</b>	<b>84.0</b>



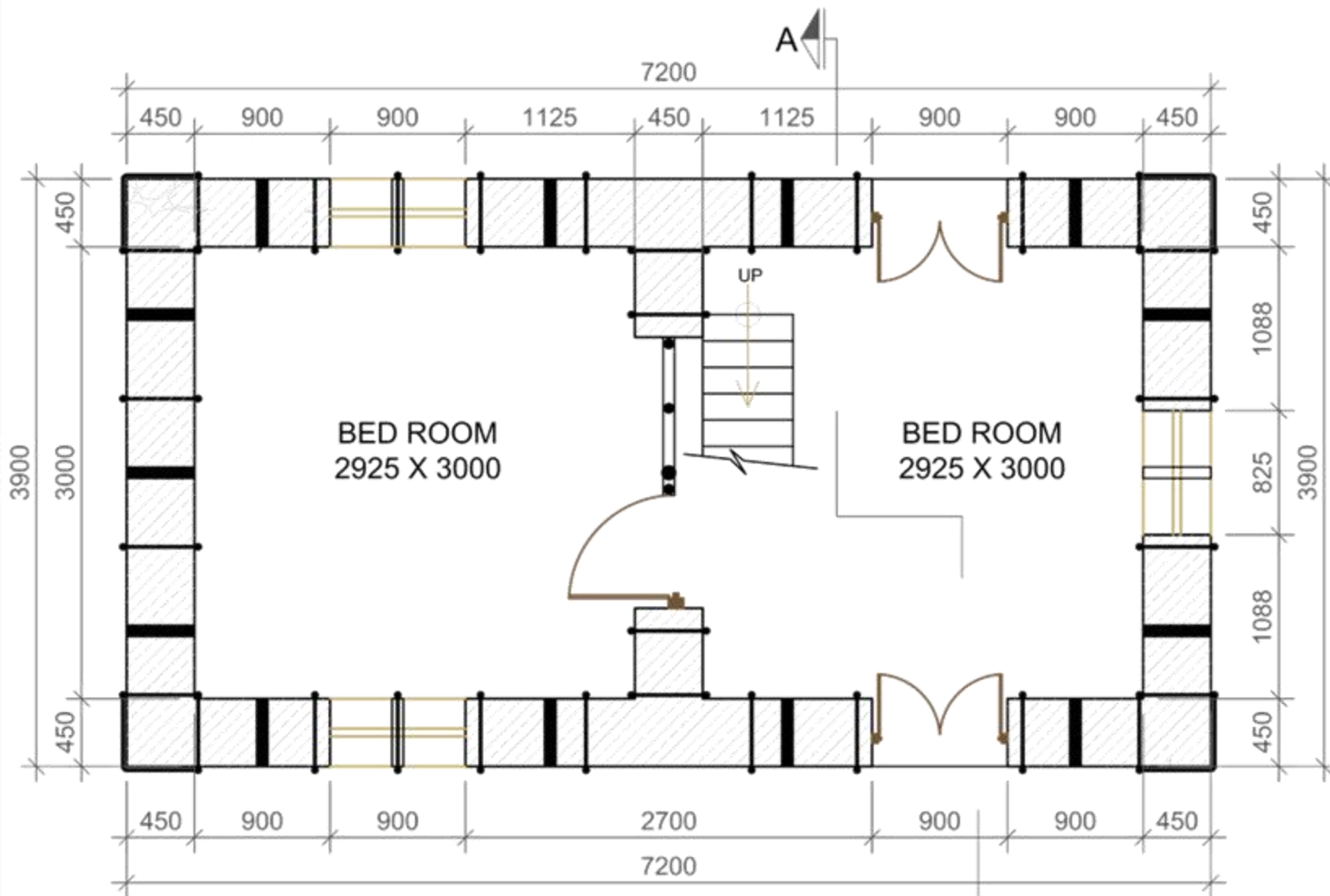

**GROUND FLOOR PLAN**  
 FLOOR AREA: 40.365 SQ. M.



MINISTRY OF URBAN DEVELOPMENT  
 DEPARTMENT OF URBAN DEVELOPMENT AND  
 BUILDING CONSTRUCTION

HOUSING TYPE: R.R.M.-5.2

DRAWING TITLE: FLOOR PLAN

SCALE: NONE

DATE:

R.R.M.-5.2

2/11



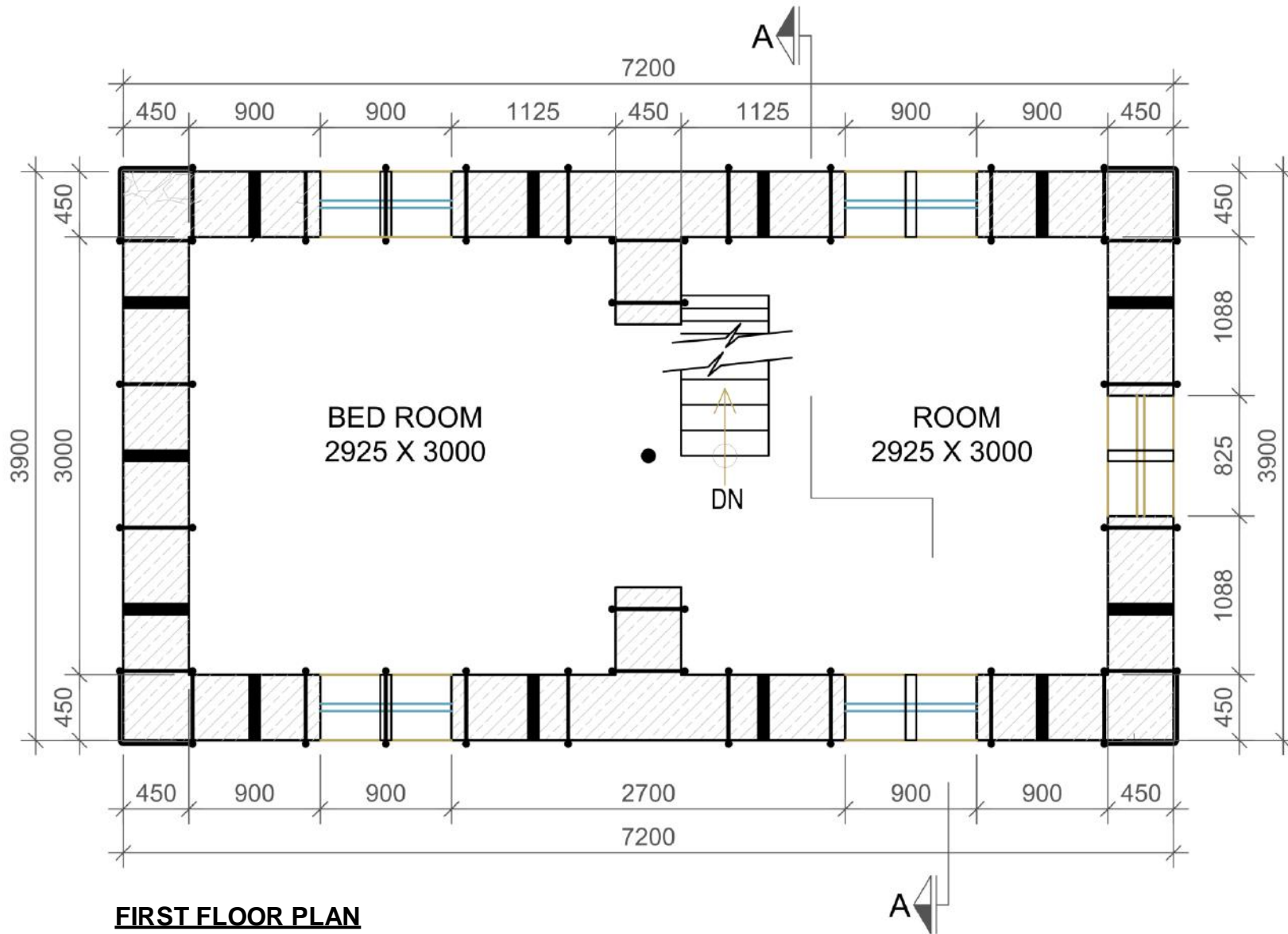

**FIRST FLOOR PLAN**

FLOOR AREA: 40.365 SQ. M



MINISTRY OF URBAN DEVELOPMENT  
DEPARTMENT OF URBAN DEVELOPMENT AND  
BUILDING CONSTRUCTION

HOUSING TYPE: R.R.M.-5.2

DRAWING TITLE: FLOOR PLAN

SCALE: NONE

DATE:

R.R.M.-5.2

3/11

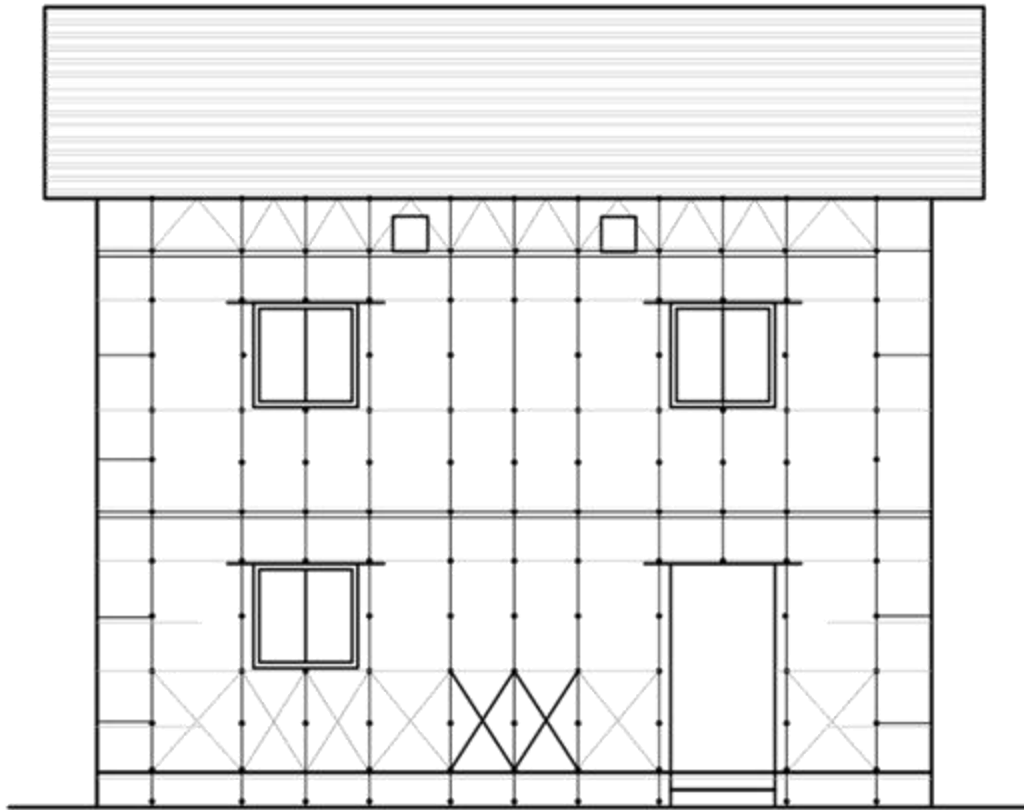

**FRONT SIDE ELEVATION**

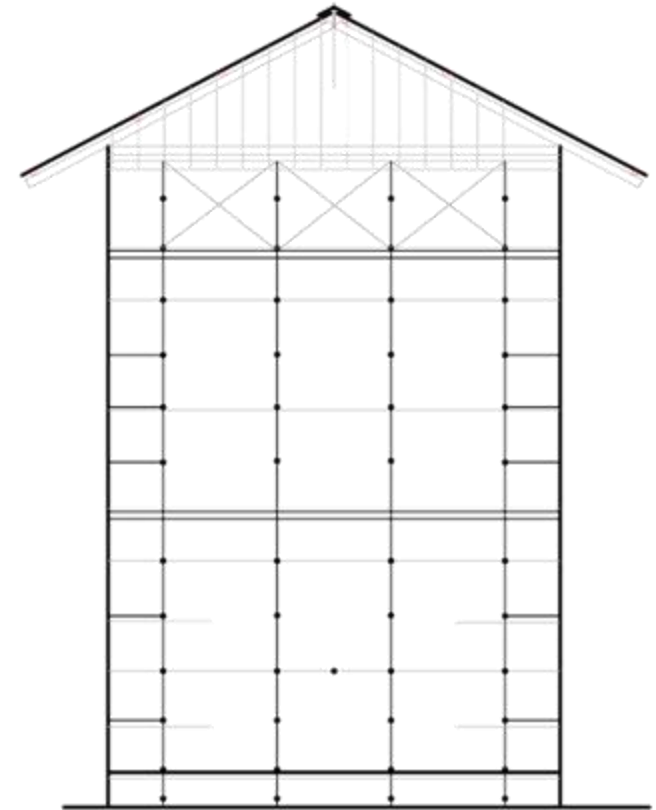

**LEFT SIDE ELEVATION**



MINISTRY OF URBAN DEVELOPMENT  
DEPARTMENT OF URBAN DEVELOPMENT AND  
BUILDING CONSTRUCTION

HOUSING TYPE: R.R.M.-5.2

DRAWING TITLE: ELEVATION

SCALE: NONE

DATE:

R.R.M-5.2

4/11

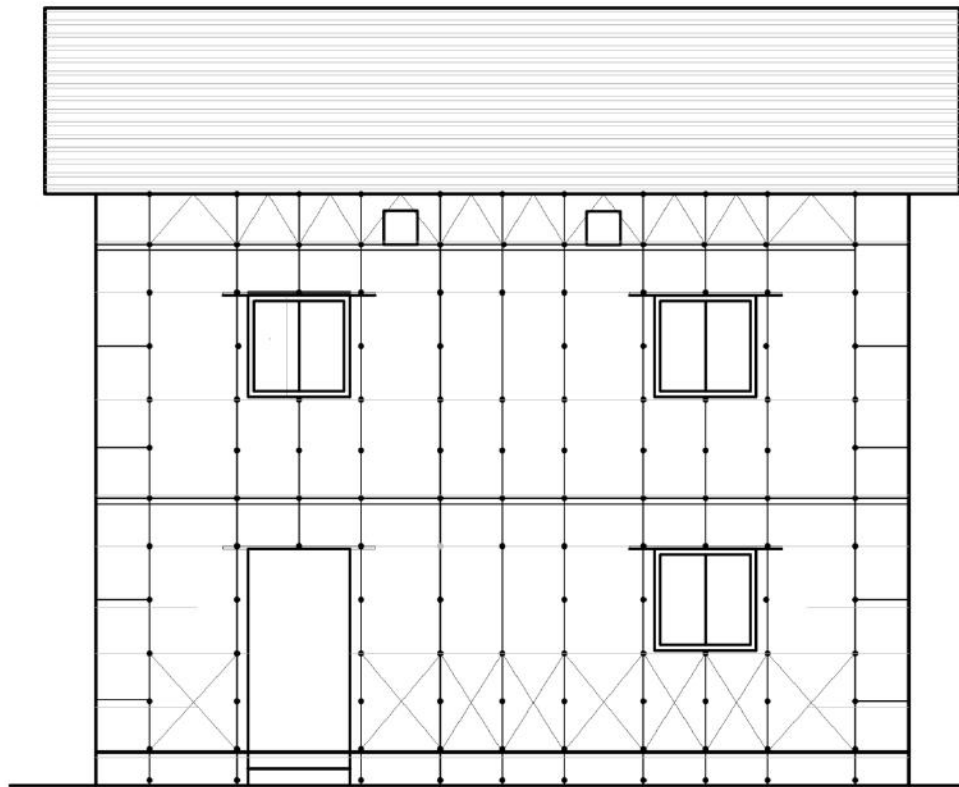

**BACK SIDE ELEVATION**

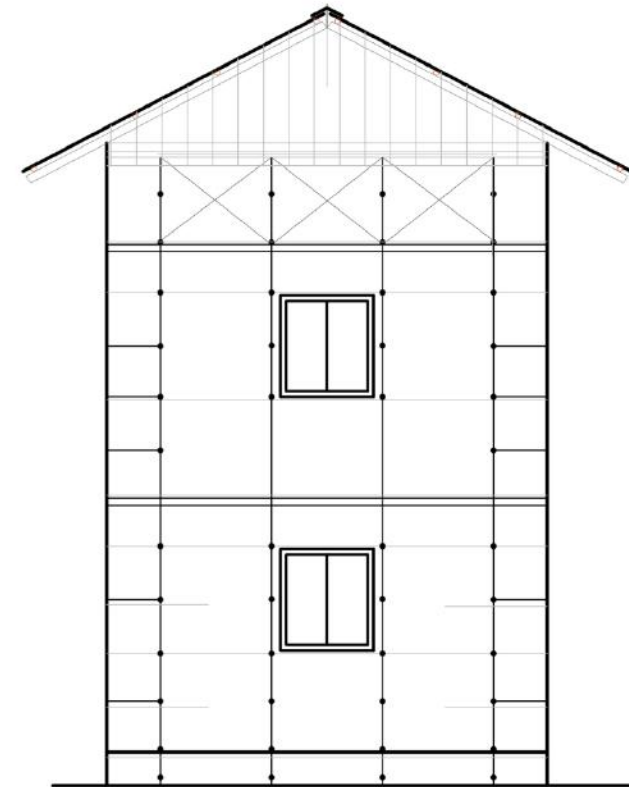

**RIGHT SIDE ELEVATION**



# MODEL R.R.M.-5.2, RANDOM RUBBLE MASONRY IN MUD MORTAR

TWO STOREY

RAFTERS- 50X100MM @ 1200MM C/C  
 PURLINS- 50X50MM @ 450MM (C/C)  
 GABLE WALL TO BE OF GI SHEETS OR TIMBER PLANKS  
 (NO MASONRY)

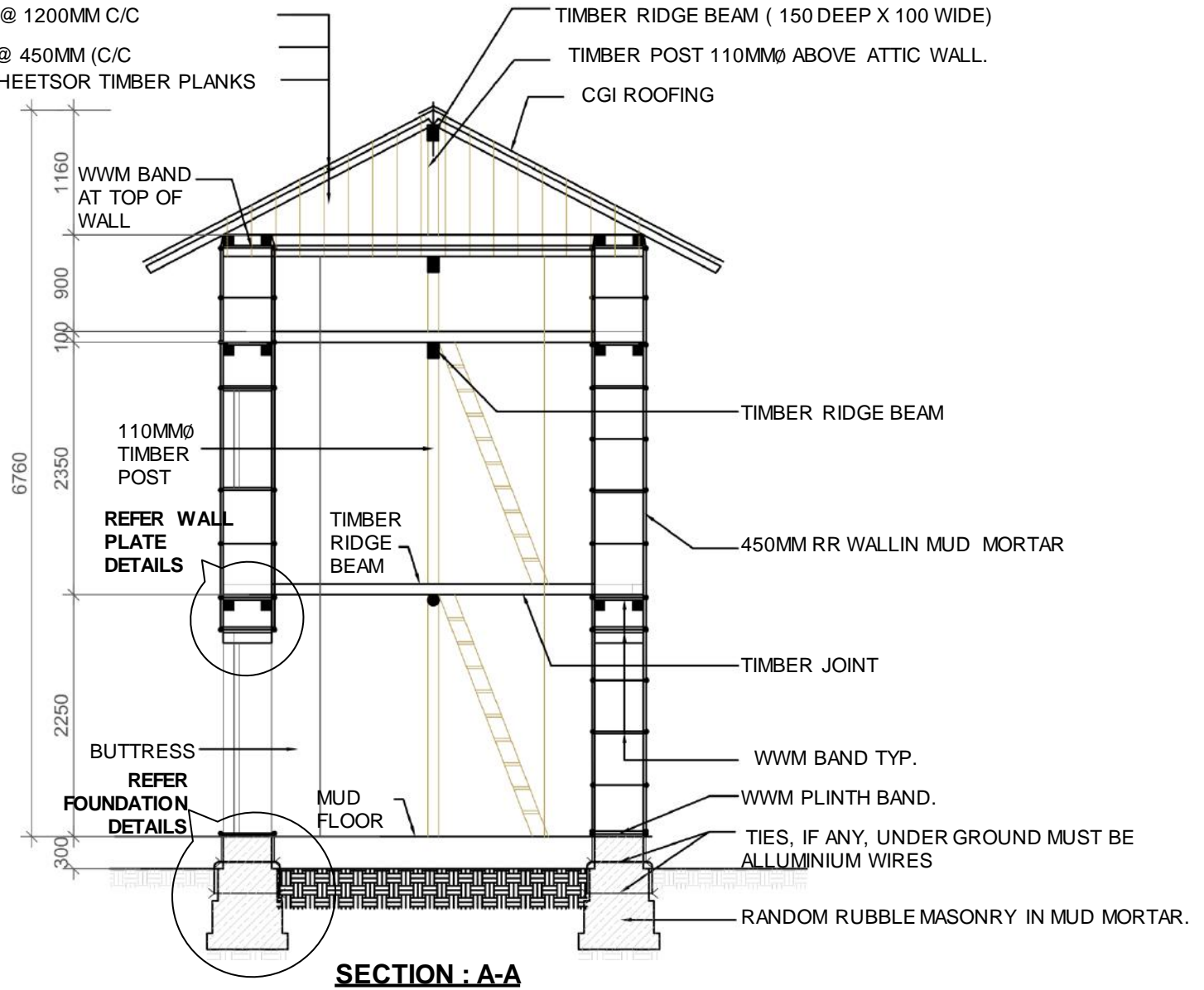

MINISTRY OF URBAN DEVELOPMENT  
 DEPARTMENT OF URBAN DEVELOPMENT AND  
 BUILDING CONSTRUCTION

HOUSING TYPE: R.R.M.-5.2

DRAWING TITLE: SECTION

SCALE: NONE

DATE:

R.R.M.-5.2

6/11

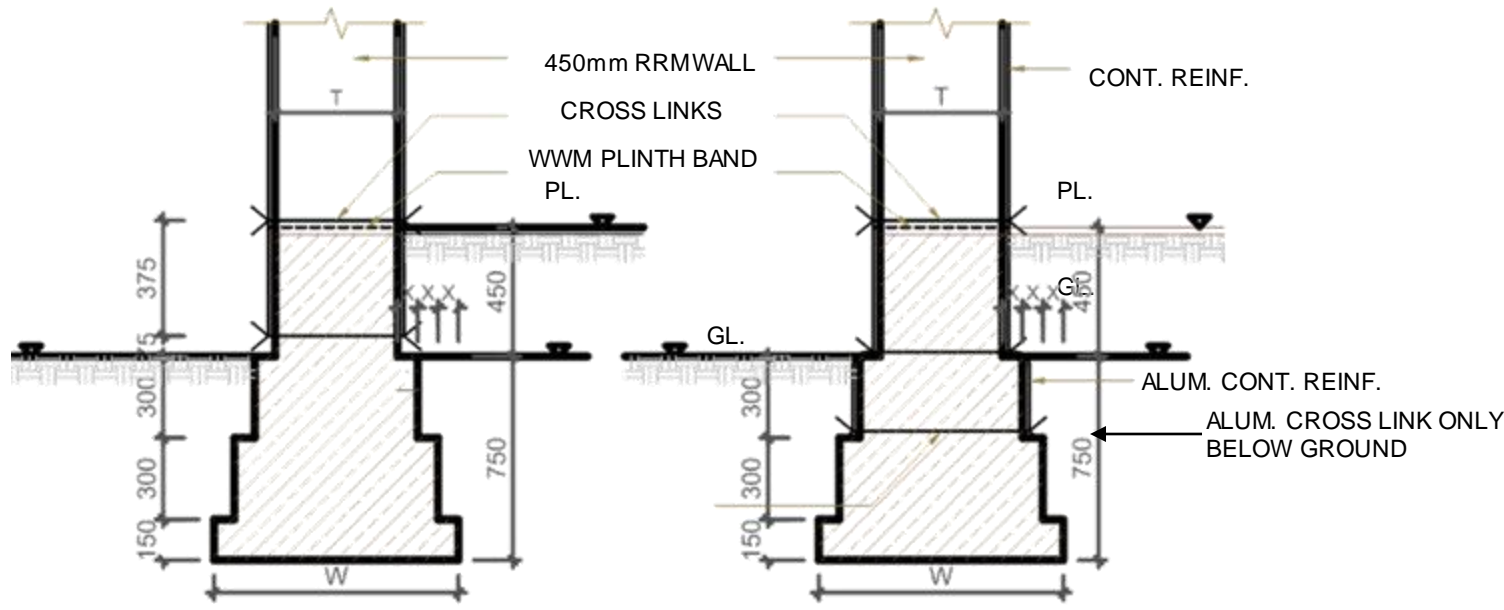

**ECONOMIC OPTION**  
(Also to be used with existing foundation)

**RECOMMENDED OPTION**  
(Only if aluminum wire are available)

**FOUNDATION DETAIL**

Soil Type	No. of storey					
	One		Two		Two plus attic	
	Width	Depth	Width	Depth	Width	Depth
Hard	750	750	750	750	750	750
Medium	750	750	750	750	750	750
Soft	750	750	900	750	900	750

**SIZE OF STRIP FOOTING FOR DIFFERENT SOIL TYPES AS PER NBC 203**

RED-OXIDE COATED OR GI WWM STRAP 350MM WIDE WITH WIRE SPACING OF 31X31MM PLUS 2-4MM GI WIRES LAID IN MUD MORTAR - SEE NOTE 5, SHEET 4.

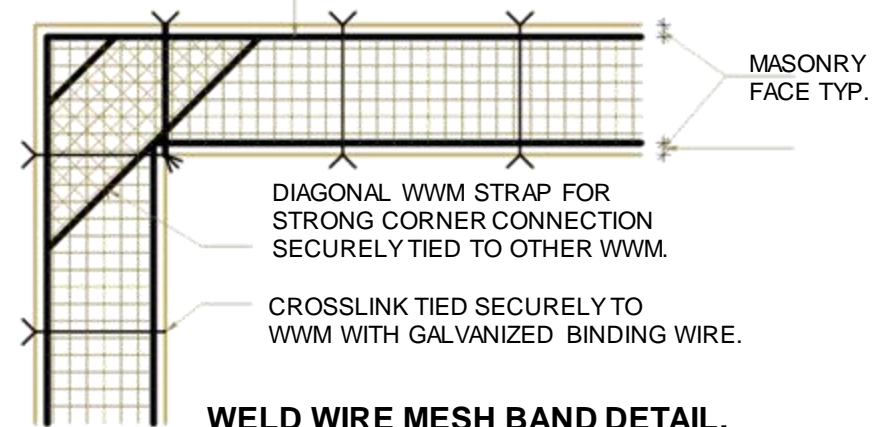

**WELD WIRE MESH BAND DETAIL.**



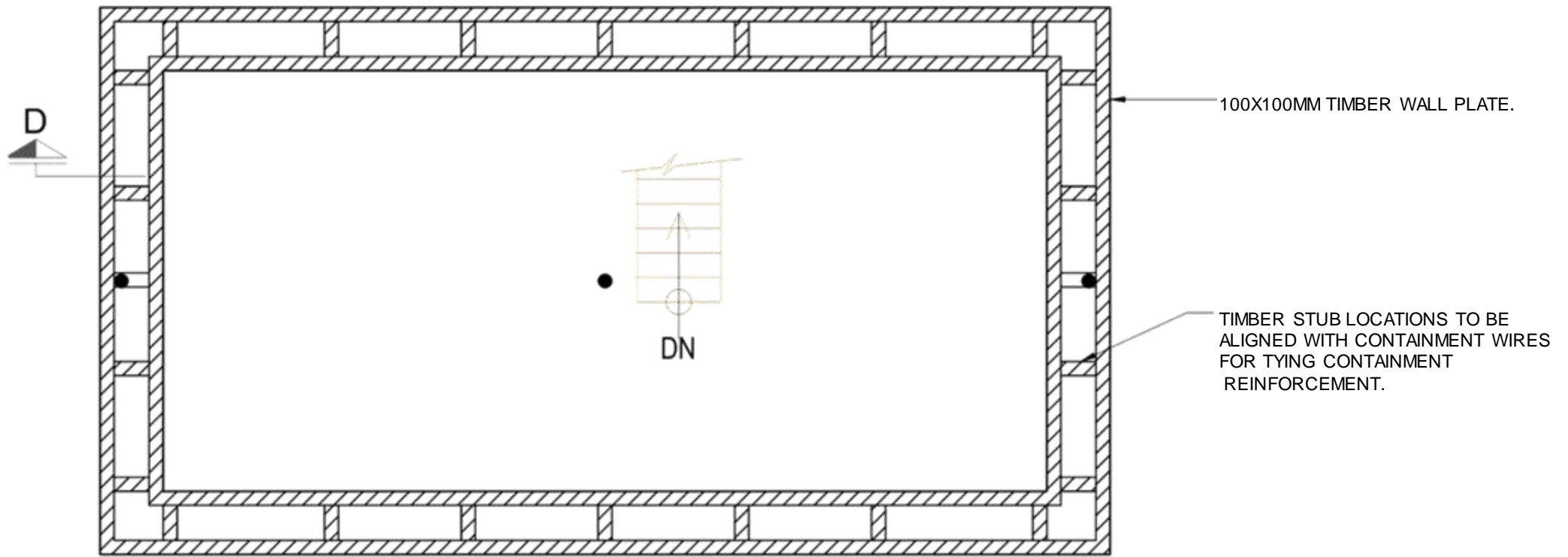

**ATTIC WALL PLATE PLAN.**

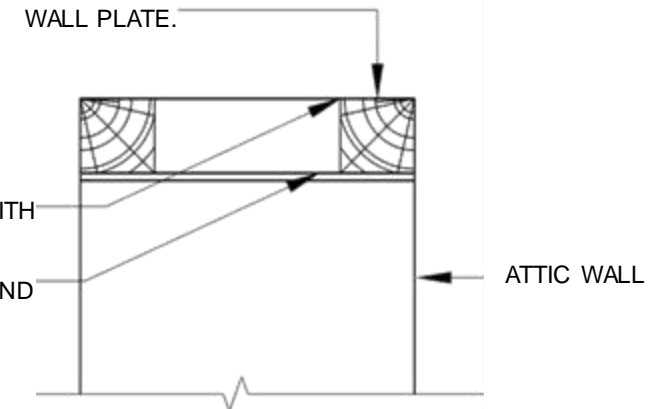

**SECTION : D-D**



MINISTRY OF URBAN DEVELOPMENT  
DEPARTMENT OF URBAN DEVELOPMENT AND  
BUILDING CONSTRUCTION

HOUSING TYPE: R.R.M.-5.1/5.2

DRAWING TITLE:DETAIL

SCALE: NONE

DATE:

R.R.M.

8/11

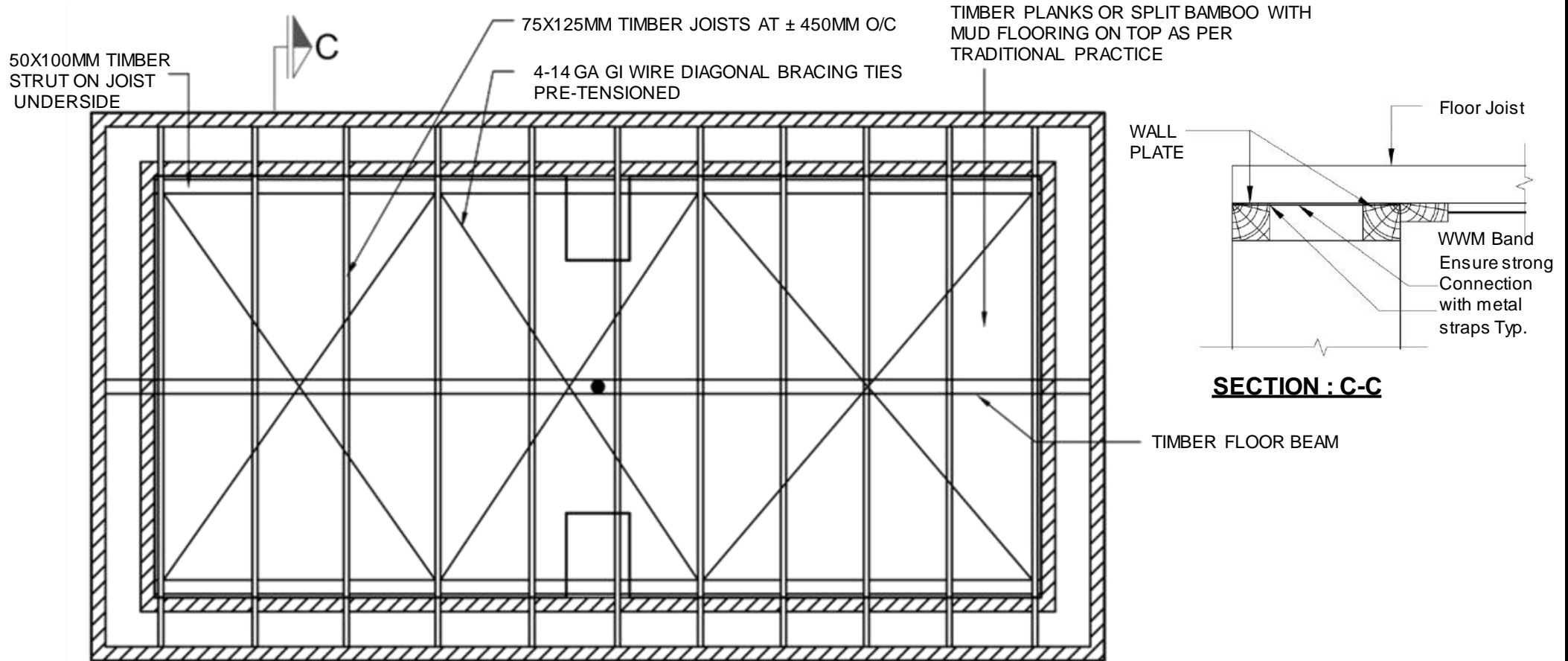

**ATTIC FLOOR TIMBER FRAMING PLAN**



MINISTRY OF URBAN DEVELOPMENT  
DEPARTMENT OF URBAN DEVELOPMENT AND  
BUILDING CONSTRUCTION

HOUSING TYPE: R.R.M.-5.1/5.2

DRAWING TITLE:DETAIL

SCALE: NONE

DATE:

R.R.M.

9/11

ALL CROSS-LINKS TO BE PLACED AT PLINTH AND LOWER LEVELS AS SHOWN IN FOUNDATION DETAILS, AND ABOVE PLINTH LEVEL AT APPROXIMATELY 450MM VERTICAL SPACING DURING THE CONSTRUCTION OF WALL.

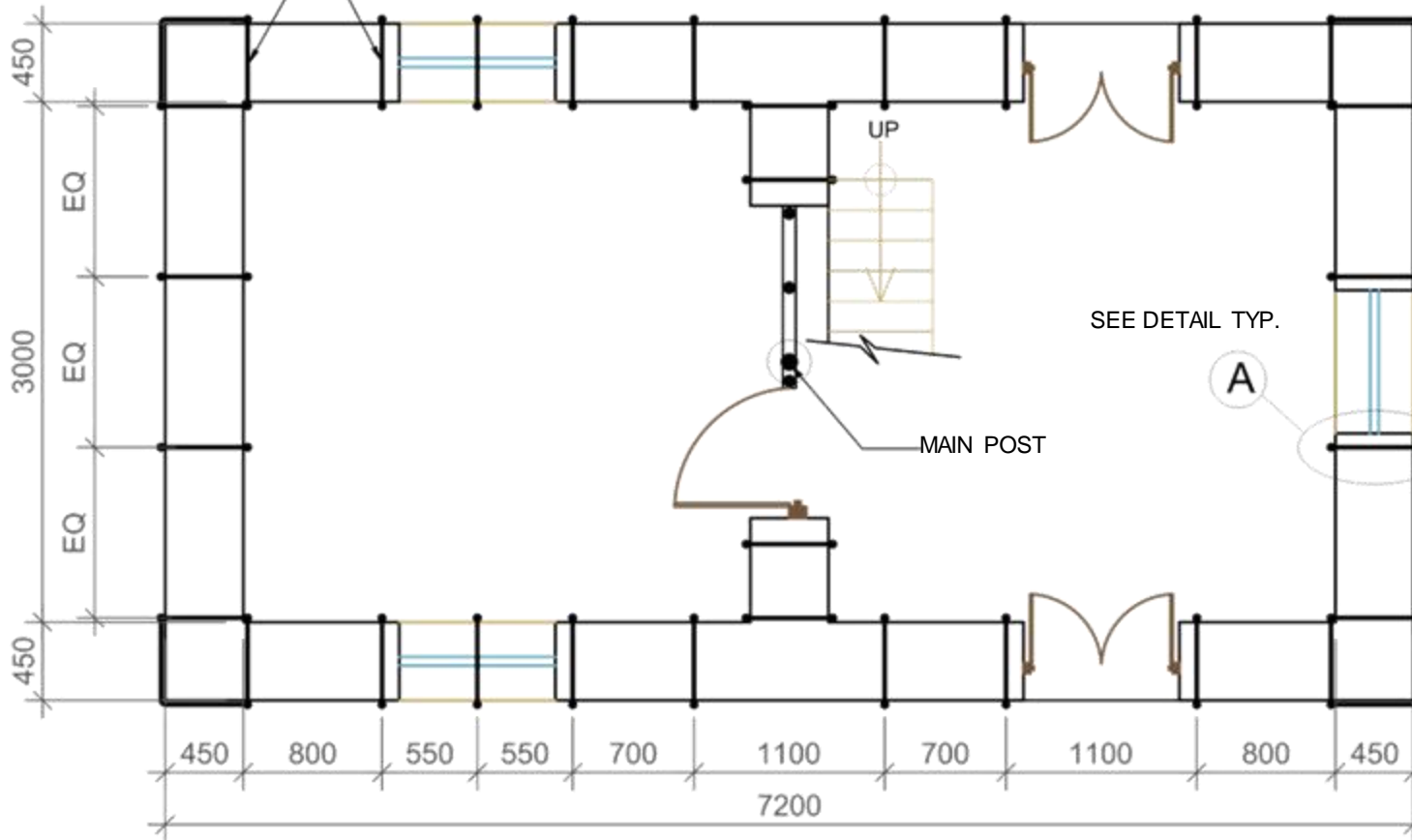

**LOCATION OF CROSS LINKS TO BE PLACED IN ALL STORIES.**

**DETAIL A**

GI WIRE CROSS LINK  
LENGTH EQUAL TO WALL THICKNESS.

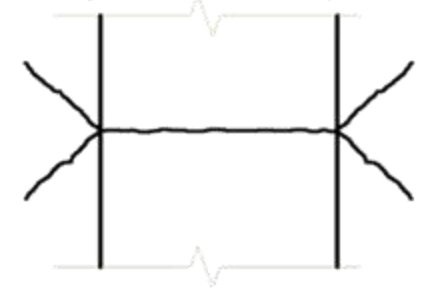

TWO 14 GA (2MM DIA) TWISTED GI WIRES WITH LOOSE ENDS EXTENDING OUT 100MM ON BOTH SIDE WALL

CROSS LINKS APPROX. 100MM AWAY FORM JAMB (TYP.)

**DETAIL A ALT**

GI WIRE CROSS LINK  
LENGTH EQUAL TO WALL THICKNESS.

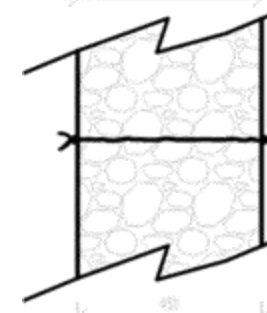

TWO 14 GA (2MM DIA) TWISTED GI WIRES WITH LOOSE ENDS EXTENDING OUT 100MM ON BOTH SIDE WALL



MINISTRY OF URBAN DEVELOPMENT  
DEPARTMENT OF URBAN DEVELOPMENT AND  
BUILDING CONSTRUCTION

HOUSING TYPE: R.R.M.-5.1/5.2

DRAWING TITLE: DETAIL

SCALE: NONE

DATE:

R.R.M.

10/11



**TECHNICAL REQUIREMENTS**

<b>Structure System</b>	Stone Masonry wall in mud mortar with Vertical GI Containment wires shall be provided on two faces of a masonry wall. The GI containment wires on the two faces are connected by ties going through walls
<b>Foundation</b>	Strip Foundation of stone masonry in mud mortar of depth 750 mm and width as specified in details for different soil type.
<b>Plinth Band</b>	Red oxide coated or GI Weld Wire mesh (WWM) strap of 350 mm width with wire spacing of 31x 31 mm plus 2 nos. 4 mm GI wires laid in mud mortar. Diagonal WWM strap need to be provided for stronger corner connection securely tied to other WWM.
<b>Wall System</b>	Random rubble masonry in mud mortar with 4 mm vertical GI wire cross linked with 2 nos. 14 gauge (2mm) galvanized iron wires placed at 450mm.
<b>Sill Band</b>	Sill band shall be of weld wire mess or wooden band as shown in detail drawing.
<b>Lintel Band:</b>	Lintel band shall be of weld wire mess or wooden band as shown in detail drawing.
<b>Floor:</b>	Mud /timber floor over timber joist (Refer drawing).
<b>Wall Plate:</b>	Wall plate shall be timber section of 100mm X 100mm placed above WWM and connected with wall (refer detail drawing)
<b>Roof:</b>	Lightweight roof of corrugated iron sheet over wooden truss. All joints in the truss shall be properly connected as shown in the drawing. All trusses shall be properly cross tied with wooden braces as shown in the drawing.



# **BAMBOO AND STONE MASONRY HYBRID STRUCTURE**

**B.S.M.H.-6.1**

The proposed technology uses traditional, yet earthquake resistant construction using materials and skills that are indigenous and locally available. Local bamboo (*Banbusa Nutans*), **seasoned and treated, is used in a structural** frame with bamboo wattle and daub panels as walls on the upper floor. The frame is surrounded with a wall in Stone Masonry with Mud Mortar on the ground floor of the house.

Featured design in H.B.S.M.-5.1 consists of a Ground Floor space that can be converted into two rooms using a lightweight Wattle and Daub partition. A Kitchen and a Covered Verandah flank the room on the short and the long side respectively.

## **MATERIAL PROPERTIES**

### **Bamboo Properties**

Min Compressive Strength of bamboo: 45.6 Mpa

Density of bamboo : 673 Kg/m<sup>3</sup>

Modulus of elasticity: 10.72 x 10<sup>3</sup> Mpa

# **B.S.M.H.-6.1**



LEVEL	MATERIALS					
	Stone	Mud	CGI Sheet	GI Sheet	Wood	Bamboo
	Cu.m.	Cu.m.	Bundle	Sq.m.	Cu.m.	Nos
Up to Plinth Level	11.6	13.0			-	230.0
Super Structure	21.3	8.1			0.6	
Roofing	-	-	5.6	9.5	0.7	
<b>TOTAL</b>	<b>32.9</b>	<b>21.1</b>	<b>5.6</b>	<b>9.5</b>	<b>1.3</b>	<b>230.0</b>



# MODEL B.S.M.H.-6.1, BAMBOO AND STONE MASONRY HYBRID STRUCTURE

TWO STOREY

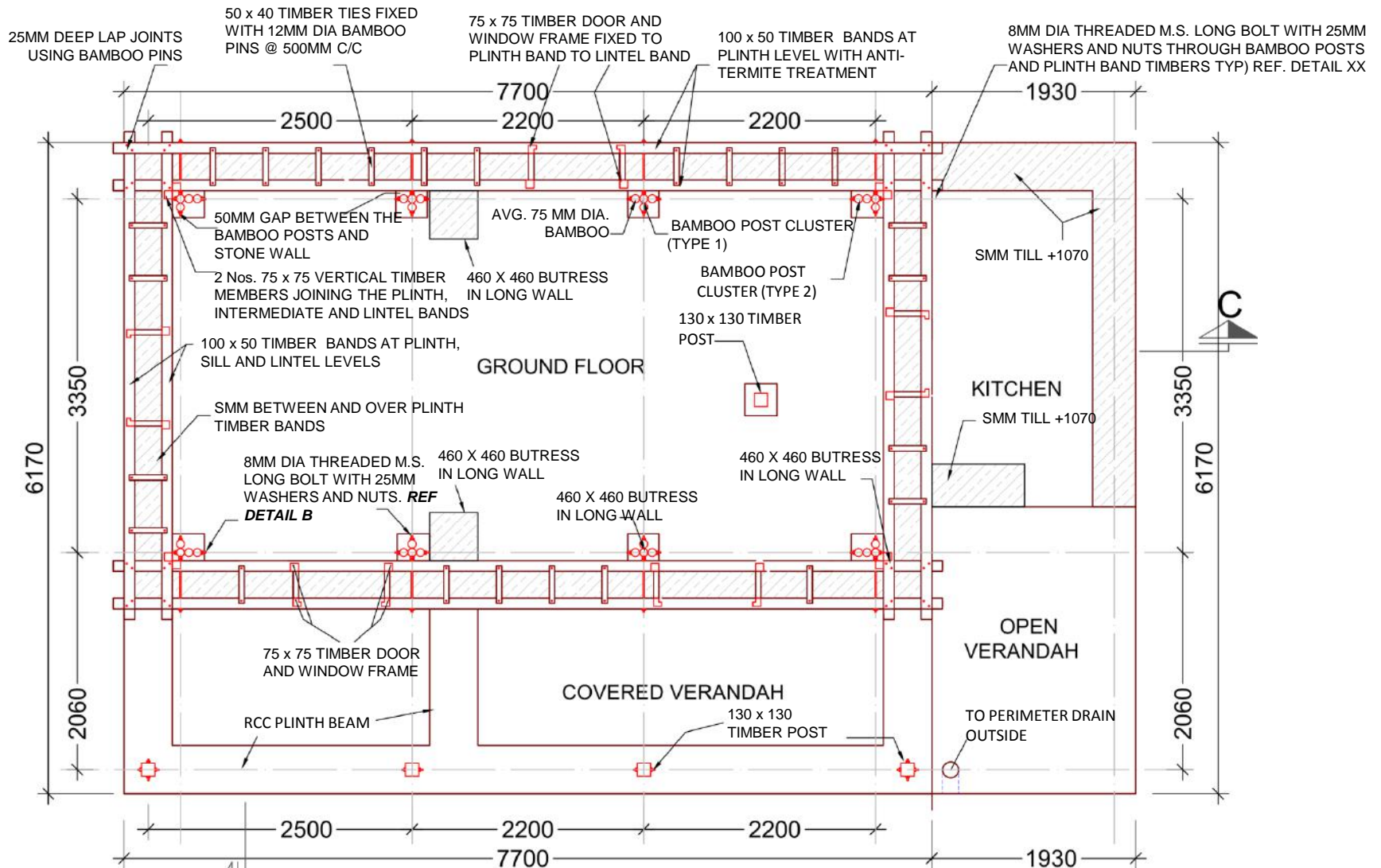

**PLAN AT +460**  
**PLINTH BAND IN LOCAL TREATED TIMBER**



MINISTRY OF URBAN DEVELOPMENT  
DEPARTMENT OF URBAN DEVELOPMENT AND  
BUILDING CONSTRUCTION

HOUSING TYPE: B.S.M.H.-6.1

DRAWING TITLE: PLAN

SCALE: NONE

DATE:

BSMH-6.1

2/14

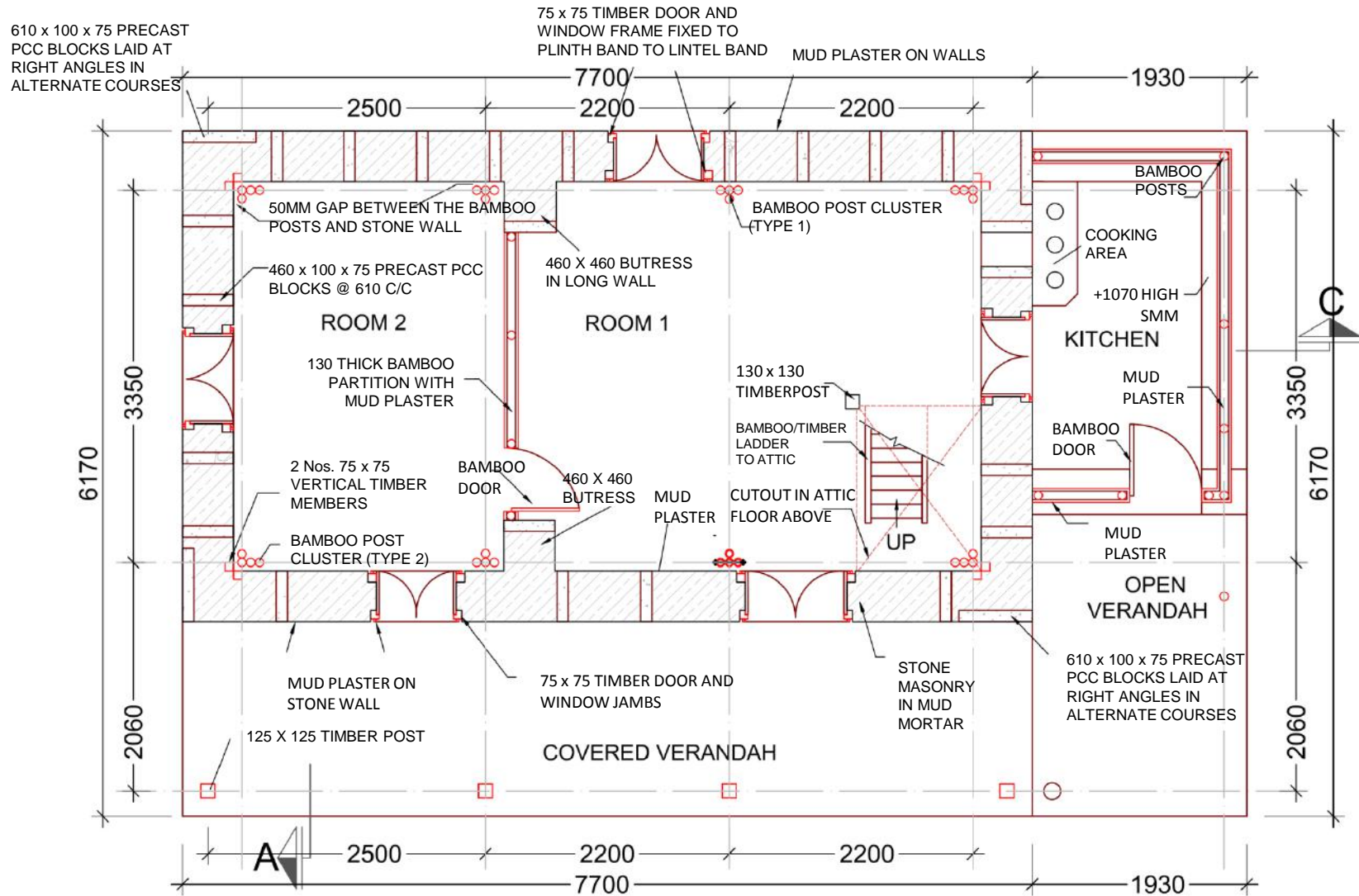

**PLAN AT +1000  
WINDOW SILL LEVEL**



MINISTRY OF URBAN DEVELOPMENT  
DEPARTMENT OF URBAN DEVELOPMENT AND  
BUILDING CONSTRUCTION

HOUSING TYPE: B.S.M.H.-6.1

DRAWING TITLE: PLAN

SCALE: NONE

DATE:

BSMH-6.1

3/14

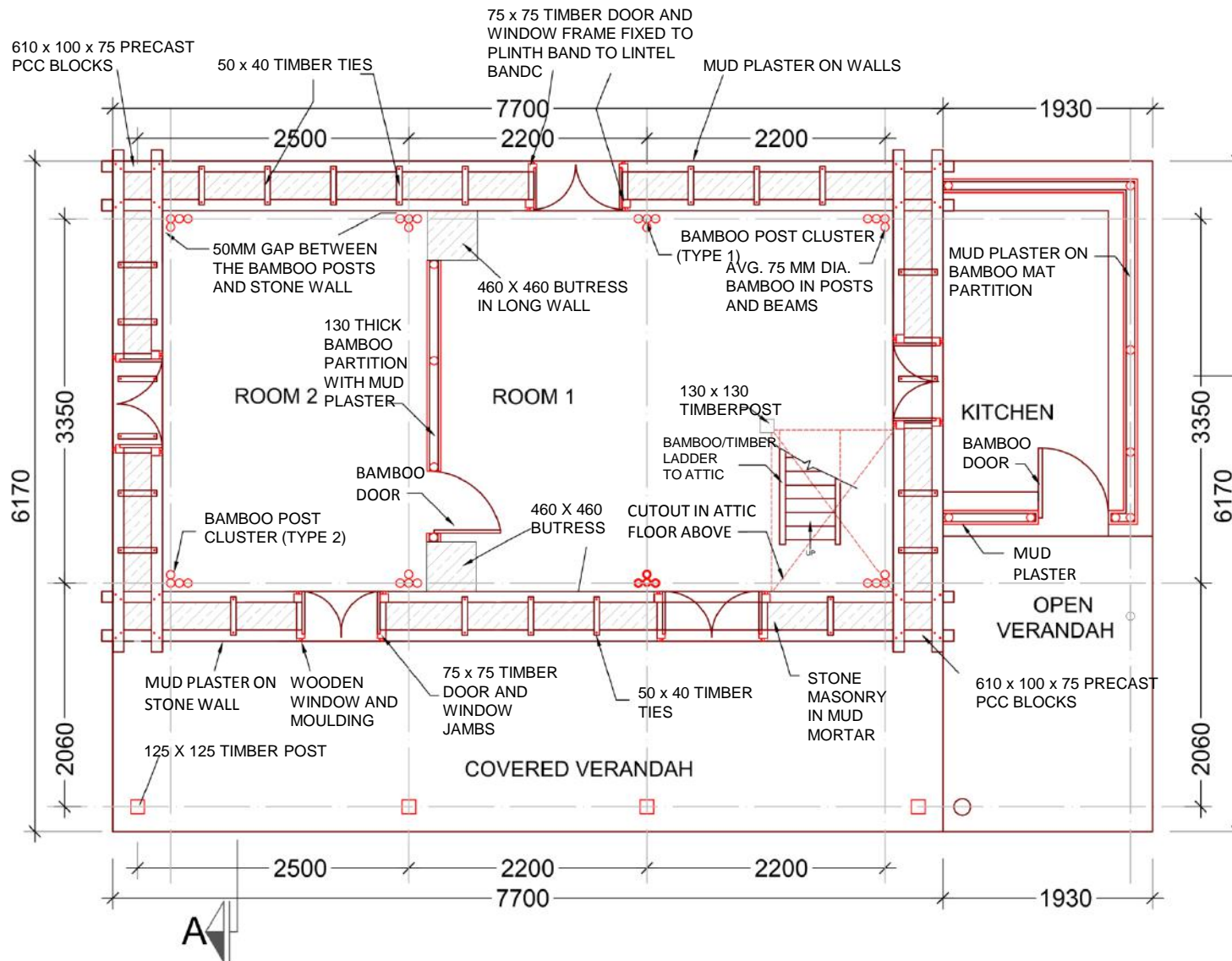

**PLAN AT +1575  
MIDDLE TIMBER BAND**



MINISTRY OF URBAN DEVELOPMENT  
DEPARTMENT OF URBAN DEVELOPMENT AND  
BUILDING CONSTRUCTION

HOUSING TYPE: B.S.M.H.-6.1

DRAWING TITLE: PLAN

SCALE: NONE

DATE:

BSMH-6.1

4/14

# MODEL B.S.M.H.-6.1, BAMBOO AND STONE MASONRY HYBRID STRUCTURE

TWO STOREY

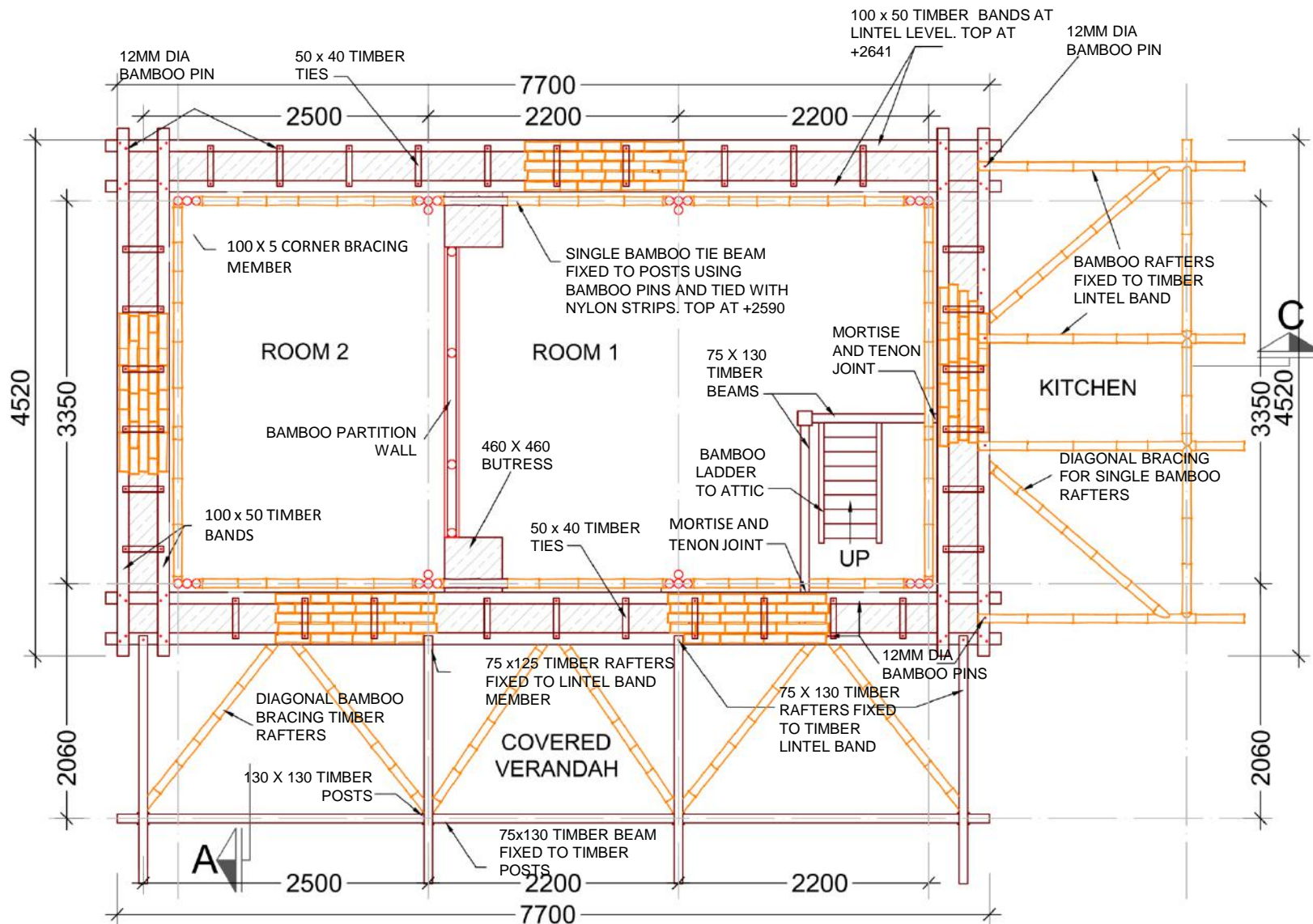

**PLAN AT +2640  
LINTEL BAND**



MINISTRY OF URBAN DEVELOPMENT  
DEPARTMENT OF URBAN DEVELOPMENT AND  
BUILDING CONSTRUCTION

HOUSING TYPE: B.S.M.H.-6.1

DRAWING TITLE: PLAN

SCALE: NONE

DATE:

BSMH-6.1

5/14



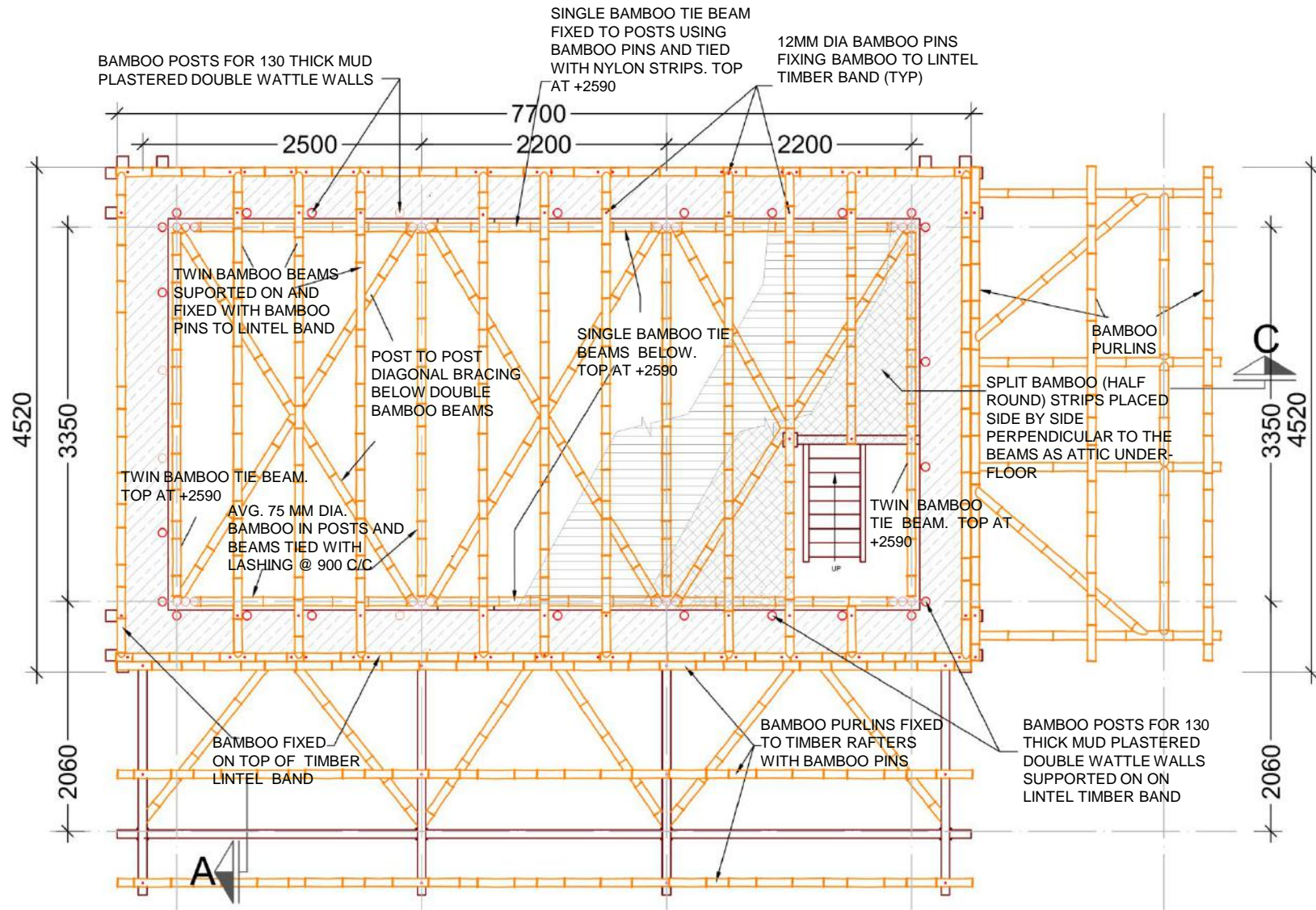

**PLAN AT +2790 (ATTIC FLOOR BEAMS)**



MINISTRY OF URBAN DEVELOPMENT  
DEPARTMENT OF URBAN DEVELOPMENT AND  
BUILDING CONSTRUCTION

HOUSING TYPE: B.S.M.H.-6.1

DRAWING TITLE: PLAN

SCALE: NONE

DATE:

BSMH-6.1

6/14

# MODEL B.S.M.H.-6.1, BAMBOO AND STONE MASONRY HYBRID STRUCTURE

TWO STOREY

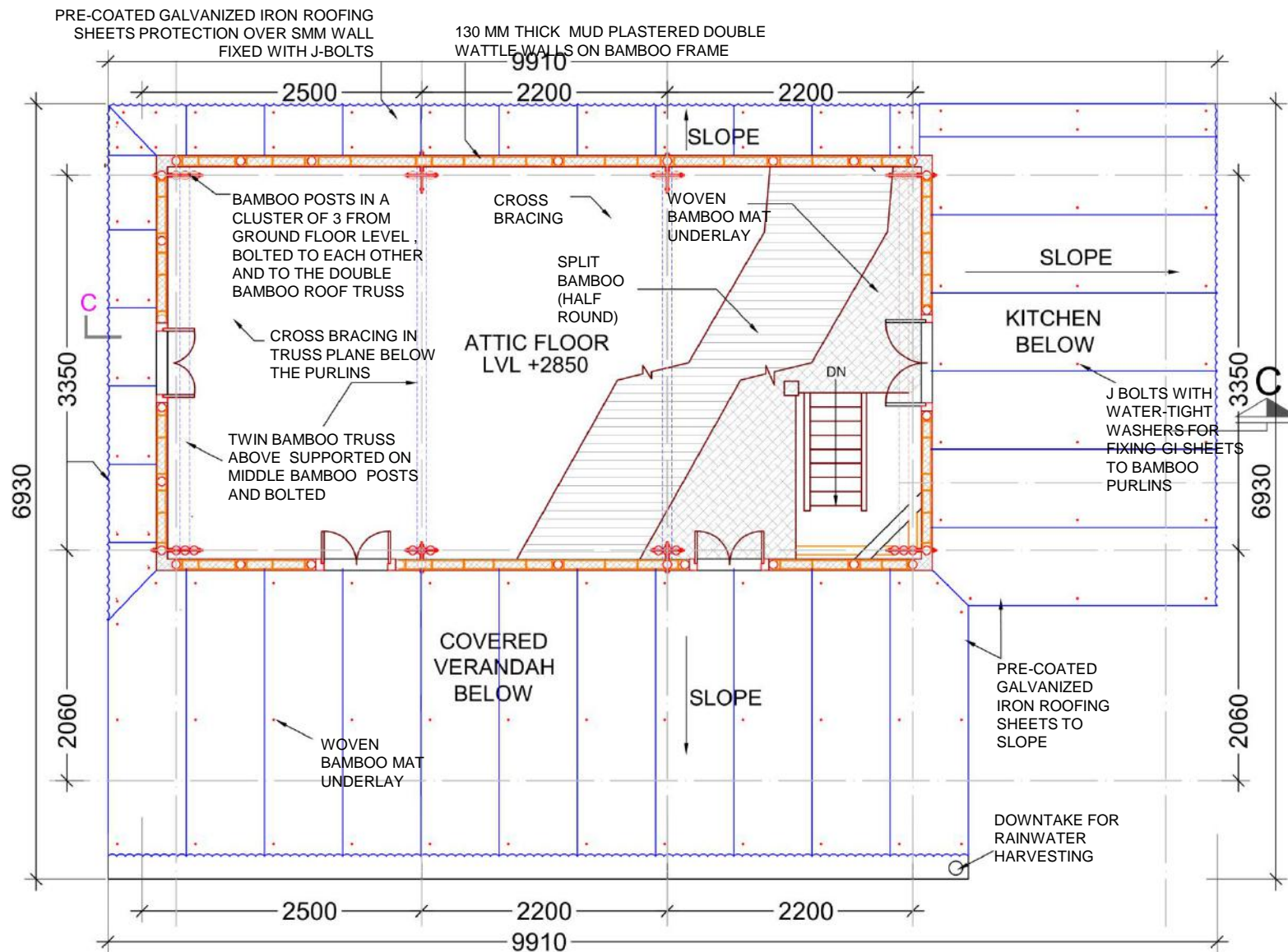

**PLAN AT +3350(ATTIC WINDOW SILL LEVEL)**



MINISTRY OF URBAN DEVELOPMENT  
DEPARTMENT OF URBAN DEVELOPMENT AND  
BUILDING CONSTRUCTION

HOUSING TYPE: B.S.M.H.-6.1

DRAWING TITLE: PLAN

SCALE: NONE

DATE:

BSMH-6.1

7/14

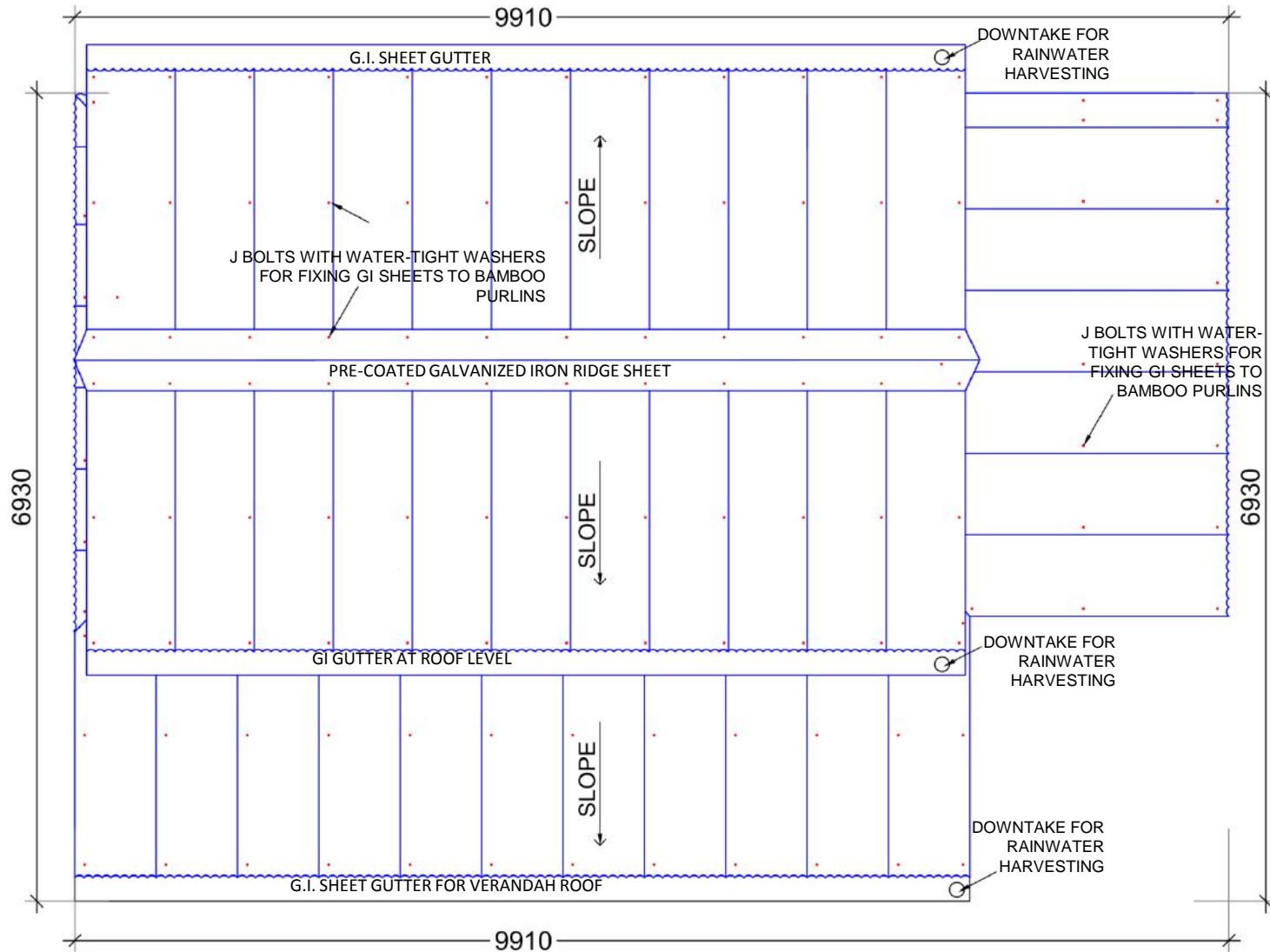

**ROOF PLAN**



MINISTRY OF URBAN DEVELOPMENT  
DEPARTMENT OF URBAN DEVELOPMENT AND  
BUILDING CONSTRUCTION

HOUSING TYPE: B.S.M.H.-6.1

DRAWING TITLE: PLAN

SCALE: NONE

DATE:

BSMH-6.1

8/14

# MODEL B.S.M.H.-6.1, BAMBOO AND STONE MASONRY HYBRID STRUCTURE

# TWO STOREY

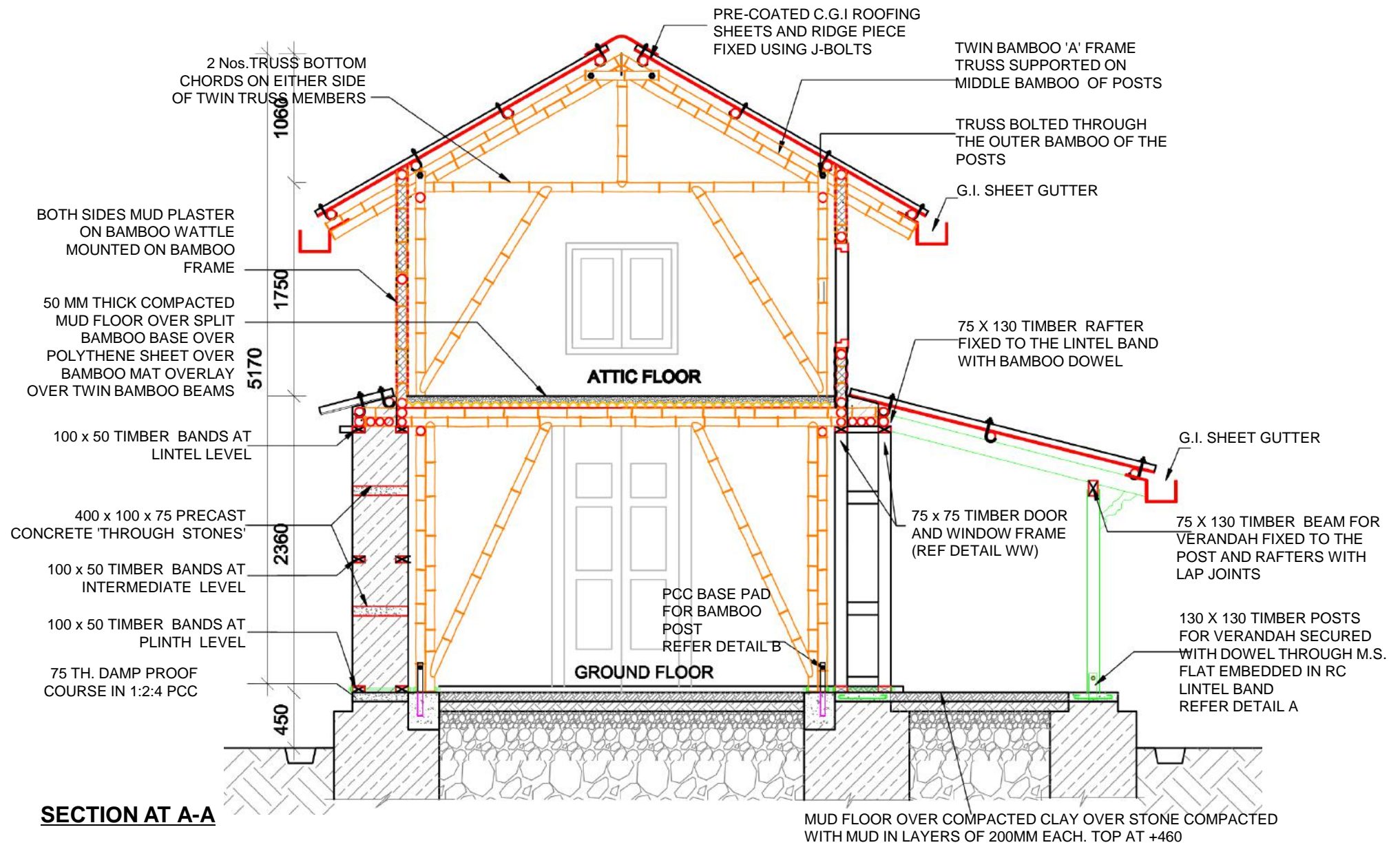

MINISTRY OF URBAN DEVELOPMENT  
DEPARTMENT OF URBAN DEVELOPMENT AND  
BUILDING CONSTRUCTION

HOUSING TYPE: B.S.M.H.-6.1

DRAWING TITLE: SECTION

SCALE: NONE

DATE:

BSMH-6.1

9/14

# MODEL B.S.M.H.-6.1, BAMBOO AND STONE MASONRY HYBRID STRUCTURE

# TWO STOREY

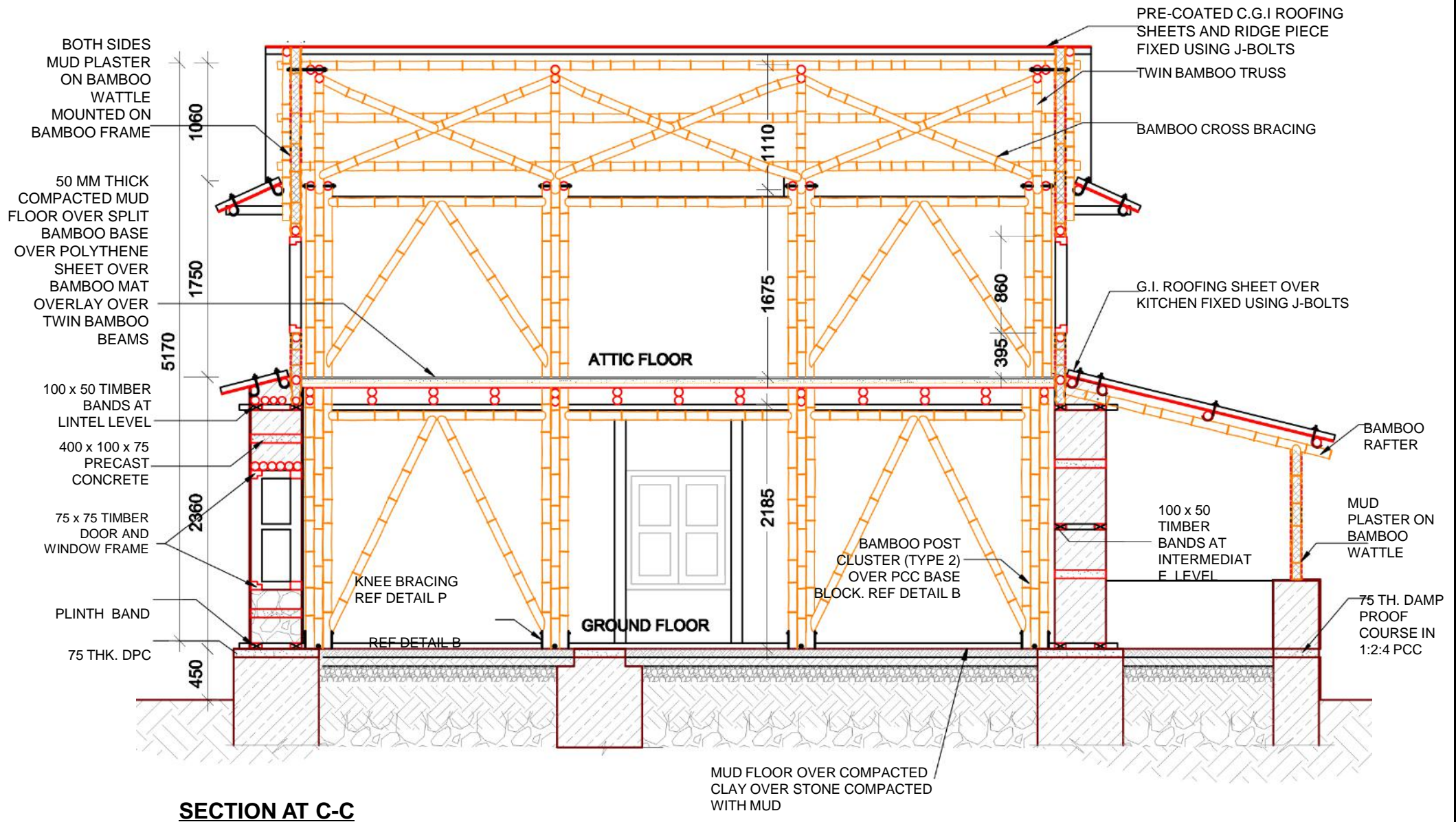

MINISTRY OF URBAN DEVELOPMENT  
DEPARTMENT OF URBAN DEVELOPMENT AND  
BUILDING CONSTRUCTION

HOUSING TYPE: B.S.M.H.-6.1

DRAWING TITLE: SECTION

SCALE: NONE

DATE:

BSMH-6.1

10/14



**FRONT ELEVATION**



**SIDE ELEVATION**



**SIDE ELEVATION**

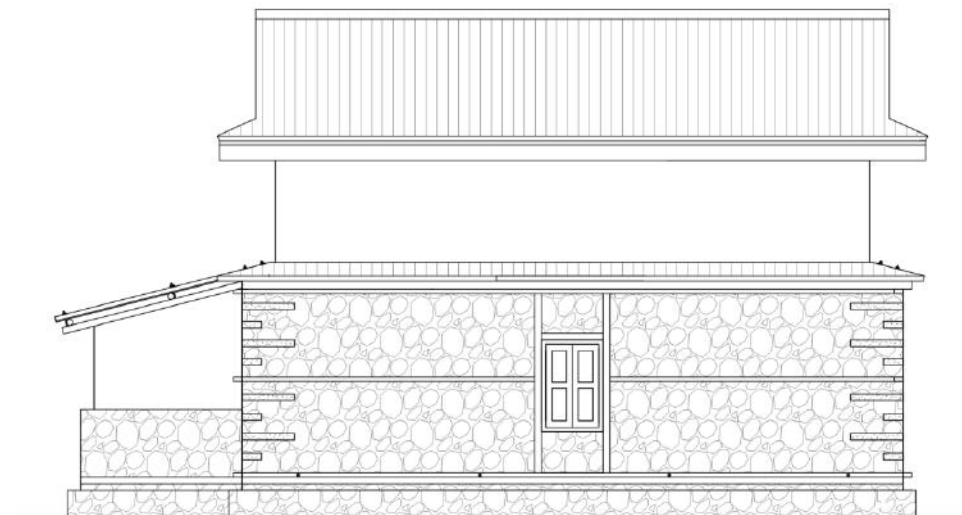

**BACK ELEVATION**



MINISTRY OF URBAN DEVELOPMENT  
DEPARTMENT OF URBAN DEVELOPMENT AND  
BUILDING CONSTRUCTION

HOUSING TYPE: B.S.M.H.-6.1

DRAWING TITLE: ELEVATIONS

SCALE: NONE

DATE:

BSMH-6.1

11/14

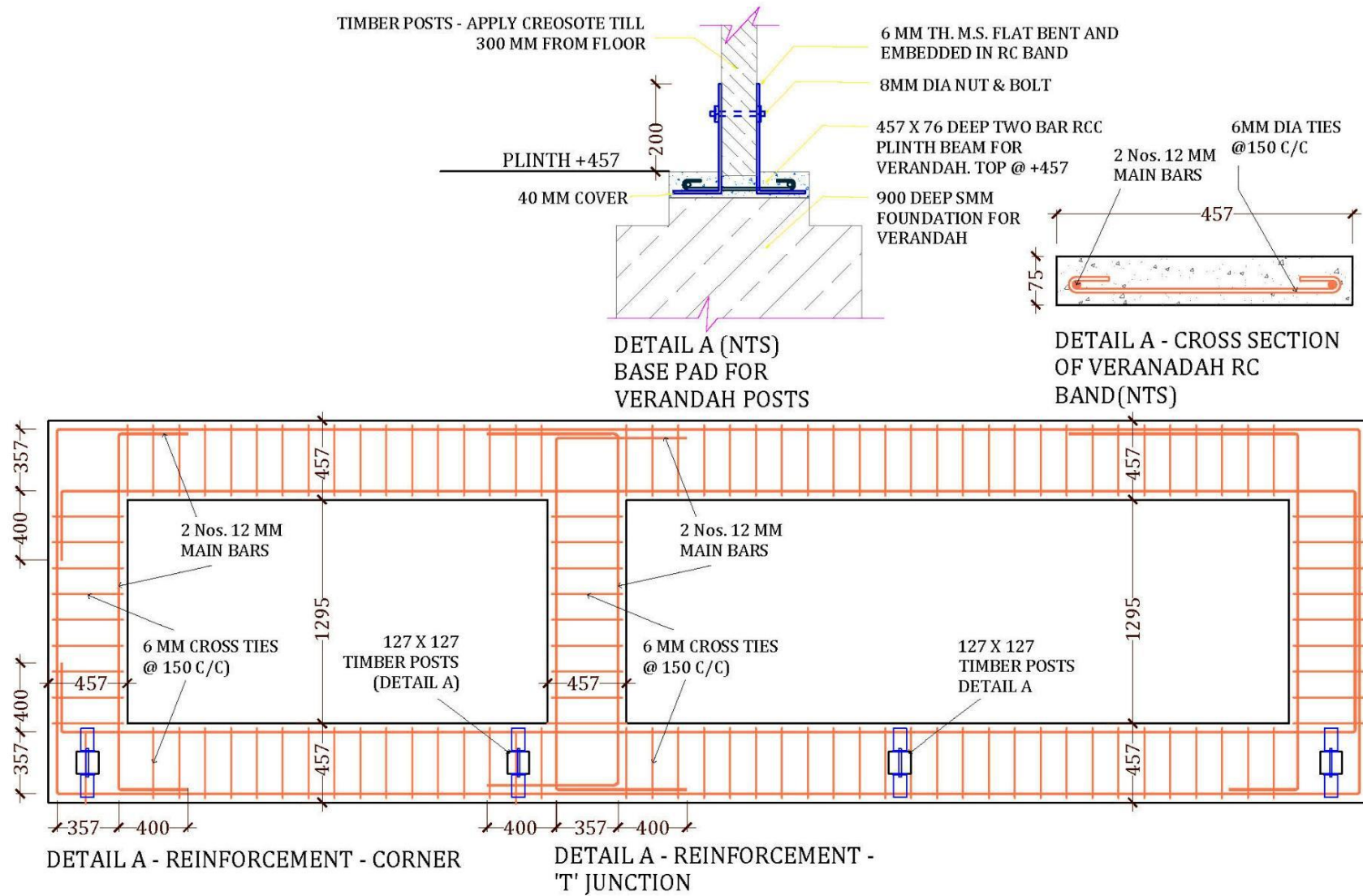

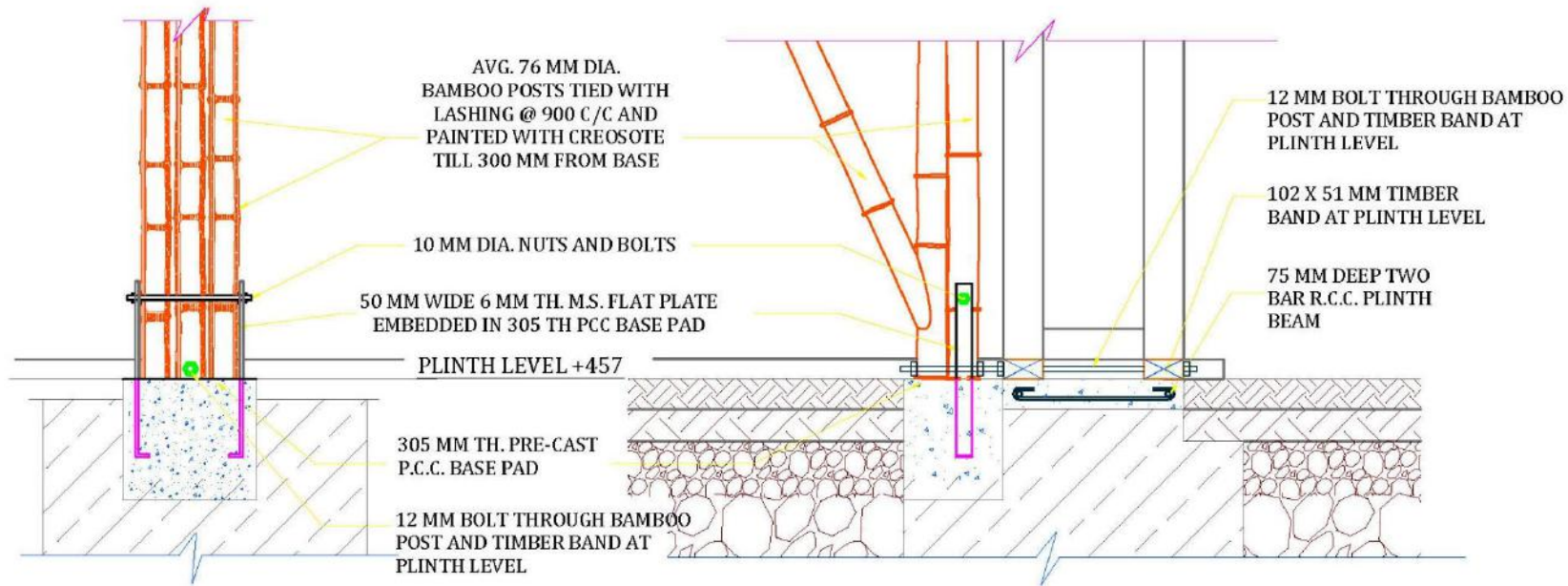

**DETAIL B (SECTION): BASE PAD FOR BAMBOO CLUSTER POSTS 'TYPE 1' AND TYPE 2'**

**DETAIL B (SIDE ELEVATION): BASE PAD FOR BAMBOO CLUSTER POSTS 'TYPE 1' AND TYPE 2'**  
 ADAPTED FROM: RE-CONSTRUCTION OF MULTI-HAZARD RESISTANT HOUSES FOR THE 2008 KOSI AFFECTED DISTRICTS IN WEST BIHAR. PART - II: TECHNICAL GUIDELINES FOR BAMBOO BASED CONSTRUCTION

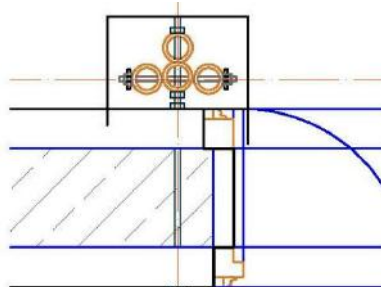

**DETAIL B (PLAN): BASE PAD FOR BAMBOO CLUSTER POSTS 'TYPE 1' AND TYPE 2'**





**TECHNICAL REQUIREMENTS**

<b>Structure System</b>	Two independent structural system; bamboo structure and stone masonry in mud mortar with 150 mm gap between them as shown in the drawings.
<b>Foundation</b>	Strip Foundation of stone masonry in mud mortar of width 850 mm and depth 750 mm. For bamboo posts, 150 x 150 mm thick PCC base pad over polythene sheet.
<b>Bands:</b>	Timber bands shall be provided at plinth, lintel and intermediate level as shown in the drawing. Band consists of two parallel timber sections of 100 x50 mm size covering entire thickness of wall. These timber shall be laterally tied with timber sections of size 38*50 mm
<b>Wall System</b>	Random rubble masonry in mud mortar. Wall thickness 457 mm
<b>Floor:</b>	50 mm thick mud flooring over split bamboos laid over joists of bamboo twins (double section) @ 400 mm c/c (Refer drawing)
<b>Roof:</b>	Lightweight roof of Corrugated Iron sheet over bamboo truss. All joints in the truss shall be properly connected as shown in the drawing.



# **RAT-TRAP BOND MASONRY**

**R.T.B.-7.1**

Rat-Trap Bond is a modular type of masonry construction in which bricks are laid on edge, thereby creating an internal cavity within the wall. The cavity improves the thermal behavior of the wall and significantly reduces the quantity of brick and mortar in the masonry. It is a Green Building technology and an appropriate option against conventional solid brick wall masonry from sustainable point of view. Rat trap bond masonry can be used both for partition wall or as a load bearing structures. As Rat trap bond construction is a modular type of masonry construction, due care must be taken while designing the wall length and height.

The design featured in Model RTB-2.1 is a two roomed single storied load bearing structure of Rat Trap bond masonry. Horizontal bands, vertical reinforcements, corner reinforcement and reinforcement in T- junctions are provided.

### **MATERIAL PROPERTIES**

Min Compressive Strength of Rat Trap Bond : 1.3 Mpa

Unit weight of RTB masonry: 15KN/m<sup>3</sup>

Young's Modulus: 715 Mpa

# **R.T.B.-7.1**



LEVEL	MATERIALS								
	Stone	Brick	Cement	Sand	Aggregate	Wood	Reinforcing Bar	CGI Sheet	GI Sheet
	Cu.m.	No.	Bags	Cu.m.	Cu.m.	Cu.m.	Kg.	Bundle	Rm.
Up to Plinth Level	19.5	2,225.0	59.0	10.3	2.5		280.4		
Super Structure		5,125.0	32.0	3.1	2.5	0.6	297.8		
Roofing		-	-	-	-	4.0	-	4.2	10.0
<b>TOTAL</b>	<b>19.5</b>	<b>7,350.0</b>	<b>91.0</b>	<b>13.4</b>	<b>5</b>	<b>4.6</b>	<b>578.2</b>	<b>4.2</b>	<b>10.0</b>



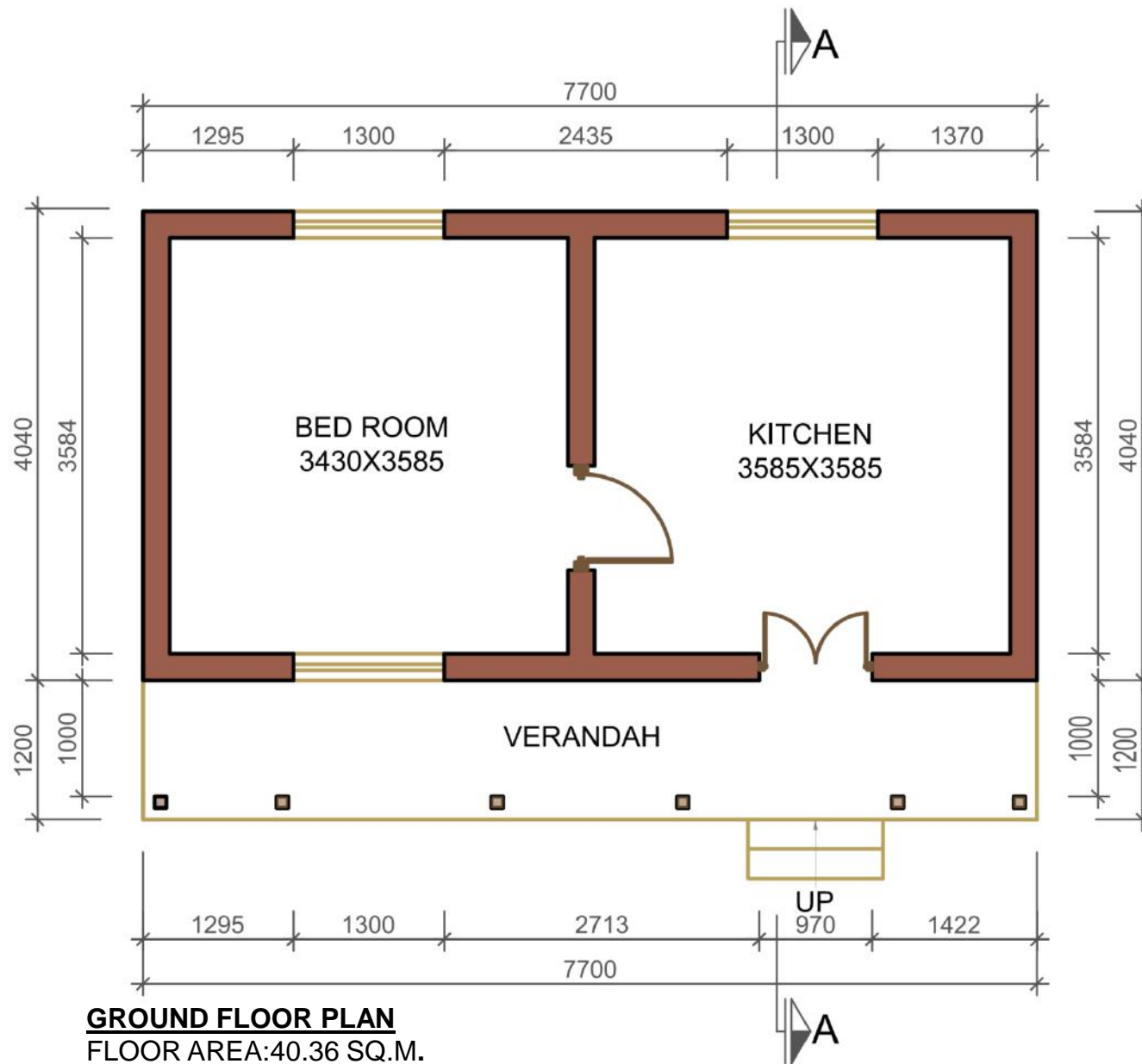

MINISTRY OF URBAN DEVELOPMENT  
DEPARTMENT OF URBAN DEVELOPMENT AND  
BUILDING CONSTRUCTION

HOUSING TYPE: R.T.B.-7.1

DRAWING TITLE: GROUND FLOOR PLAN

SCALE: NONE

DATE:

RTB-7.1

2/10

# MODEL RTB-7.1, RAT TRAP BOND MASONRY

ONE STOREY

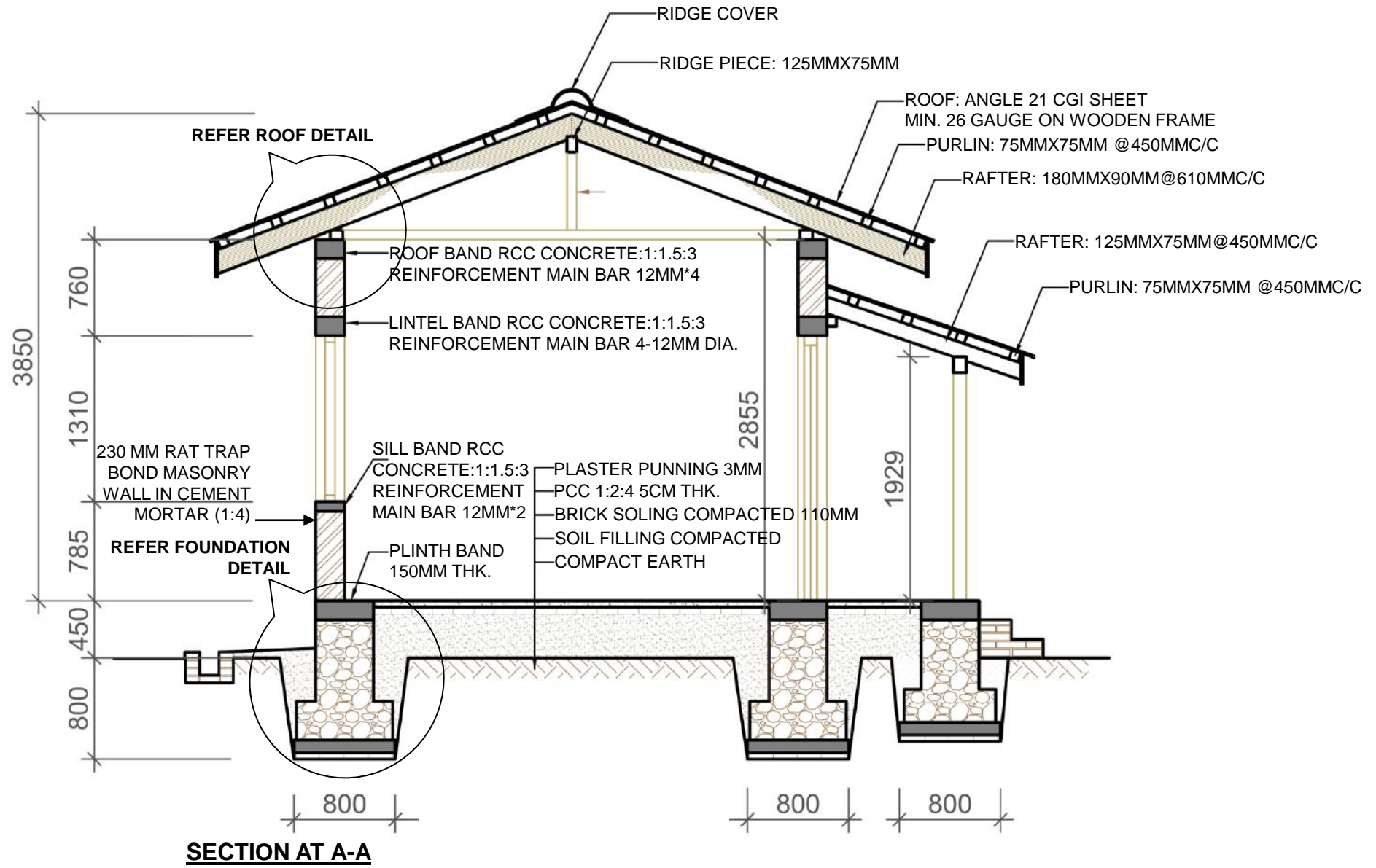

MINISTRY OF URBAN DEVELOPMENT  
 DEPARTMENT OF URBAN DEVELOPMENT AND  
 BUILDING CONSTRUCTION

HOUSING TYPE: R.T.B.-7.1

DRAWING TITLE: SECTION

SCALE: NONE

DATE:

RTB-7.1

3/10



FRONT ELEVATION



SIDE ELEVATION



SIDE ELEVATION



BACK ELEVATION



MINISTRY OF URBAN DEVELOPMENT  
DEPARTMENT OF URBAN DEVELOPMENT AND  
BUILDING CONSTRUCTION

HOUSING TYPE: R.T.B.-7.1

DRAWING TITLE: ELEVATIONS

SCALE: NONE

DATE:

RTB-7.1

4/10

# MODEL RTB-7.1, RAT TRAP BOND MASONRY

ONE STOREY

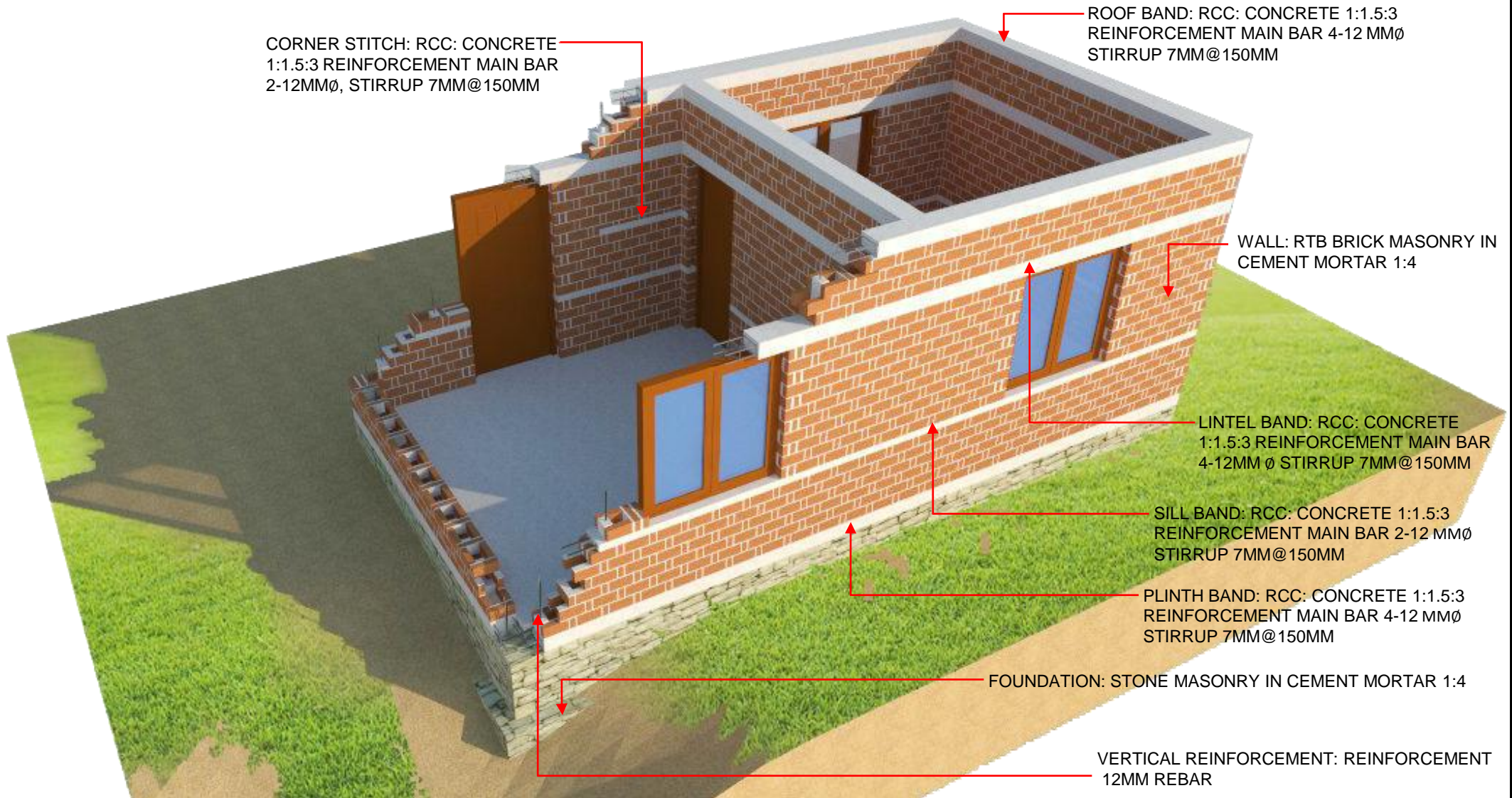

## TECHNOLOGY FOR EARTHQUAKE RESISTANT BUILDING CONSTRUCTION (RAT-TRAP BOND BRICK MASONRY IN CEMENT MORTAR)

 <p>MINISTRY OF URBAN DEVELOPMENT DEPARTMENT OF URBAN DEVELOPMENT AND BUILDNG CONSTRUCTION</p>	HOUSING TYPE: R.T.B.-7.1	SCALE: NONE	RTB-7.1
	DRAWING TITLE:SECTIONAL PERSPECTIVE	DATE:	



# MODEL RTB-7.1, RAT TRAP BOND MASONRY

ONE STOREY

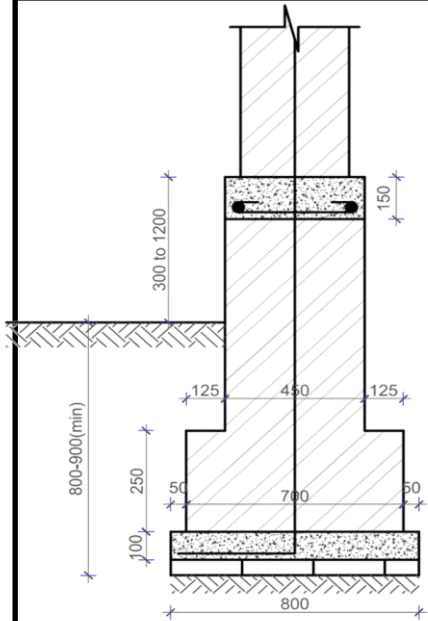

**DETAIL C**  
**FOUNDATION SECTION**

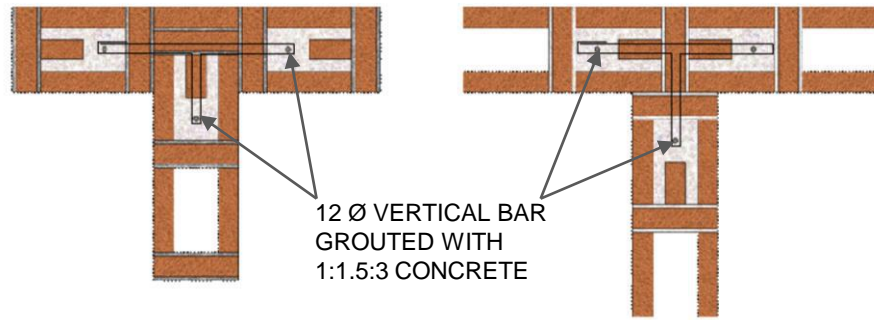

LAYER 1

LAYER 2

**RAT-TRAP BOND IN T-JUNCTION**

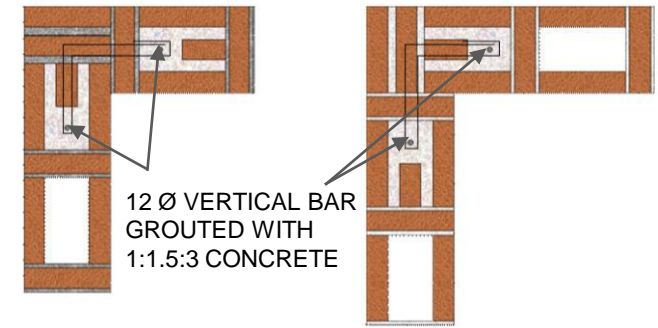

LAYER 1

LAYER 2

**RAT-TRAP BOND IN CORNER JUNCTION**

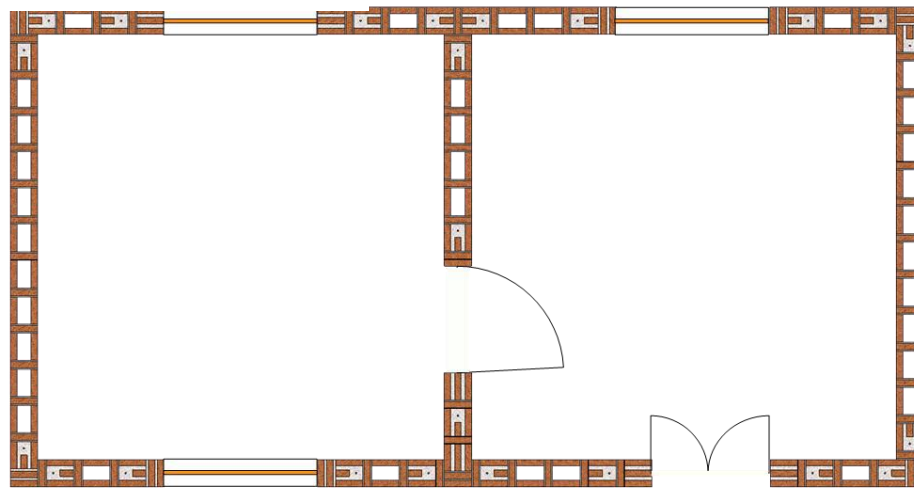

**RAT-TRAP LAYER 1**

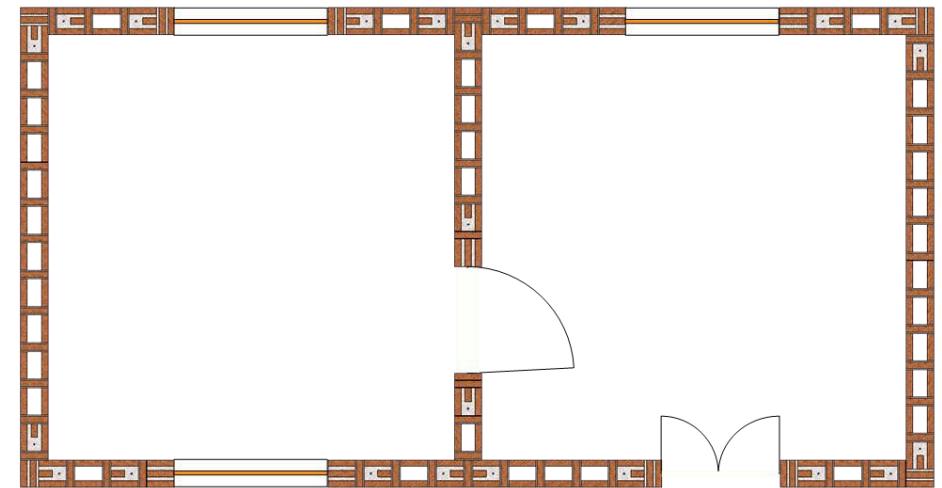

**RAT-TRAP LAYER 2**



MINISTRY OF URBAN DEVELOPMENT  
DEPARTMENT OF URBAN DEVELOPMENT AND  
BUILDING CONSTRUCTION

HOUSING TYPE: R.T.B.-7.1

DRAWING TITLE: DETAILS

SCALE: NONE

DATE:

RTB-7.1

6/10

# MODEL RTB-7.1, RAT TRAP BOND MASONRY

ONE STOREY

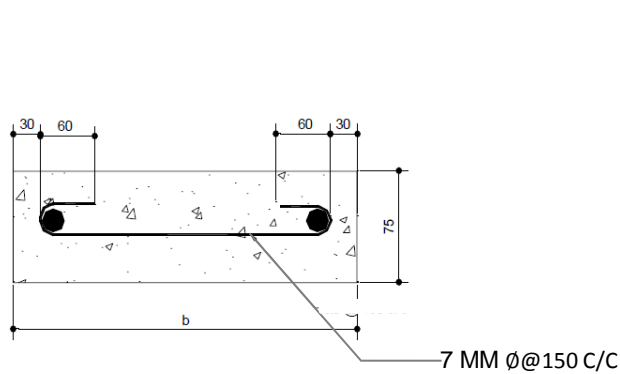

**CROSS SECTION OF RC BANDS FOR TWO BARS AND FOUR BARS**

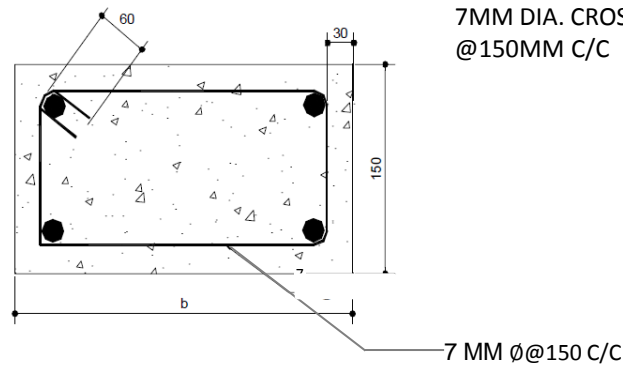

7MM DIA. CROSS TIES @150MM C/C

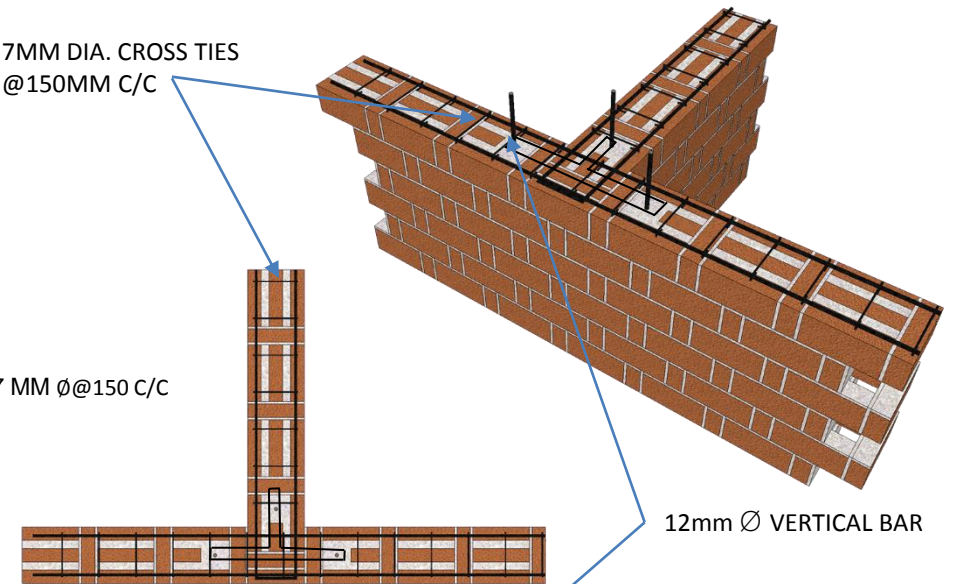

**REQUIREMENT OF BAR FOR RC BANDS**

BAND/BEAM	RC BAND MINIMUM THICKNESS	MIN. NO. OF BARS	MIN. DIAMETER OF BARS (MM)
PLINTH	150MM	4	12
SILL	75MM	2	12
LINTEL	150MM	4	12
ROOF/ GABLE	150MM	4	12
CORNER STITCH	75MM	2	12

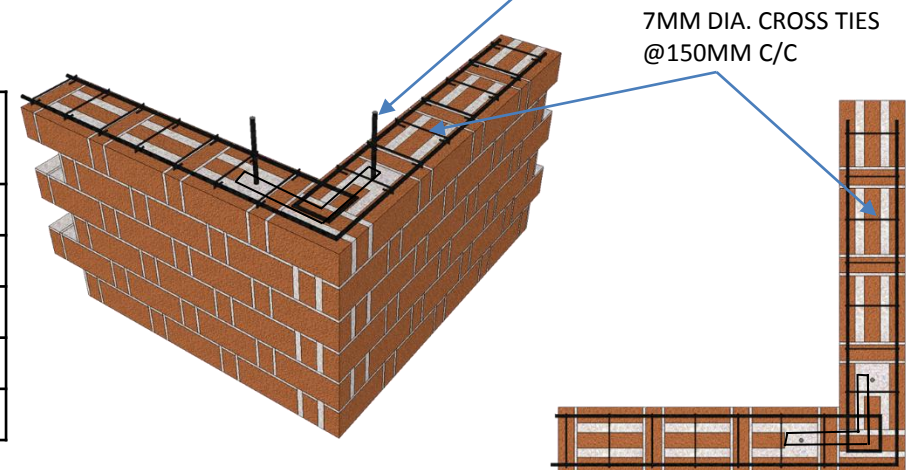

**RCC BAND AT CORNER AND T-JUNCTION**



MINISTRY OF URBAN DEVELOPMENT  
DEPARTMENT OF URBAN DEVELOPMENT AND  
BUILDING CONSTRUCTION

HOUSING TYPE: R.T.B.-7.1

DRAWING TITLE: DETAILS

SCALE: NONE

DATE:

RTB-7.1

7/10

# MODEL RTB-7.1, RAT TRAP BOND MASONRY

ONE STOREY

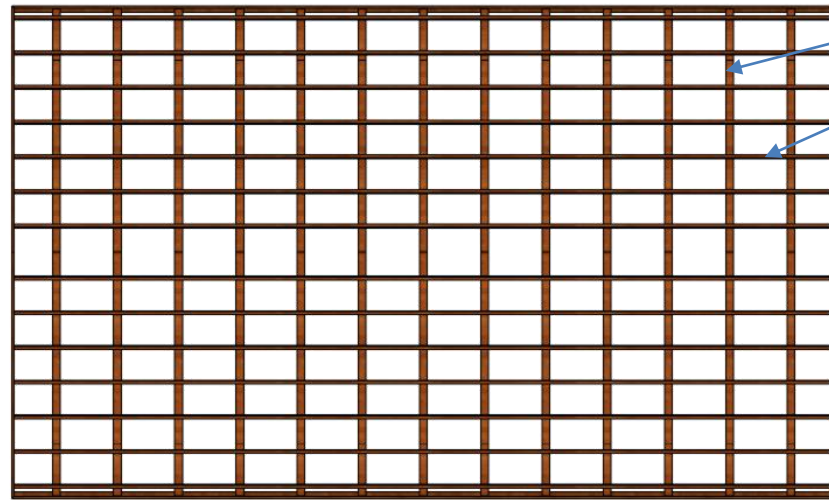

**TOP (PLAN) VIEW**

RAFTER (H180 X W90)  
PURLIN (H75 X W75)

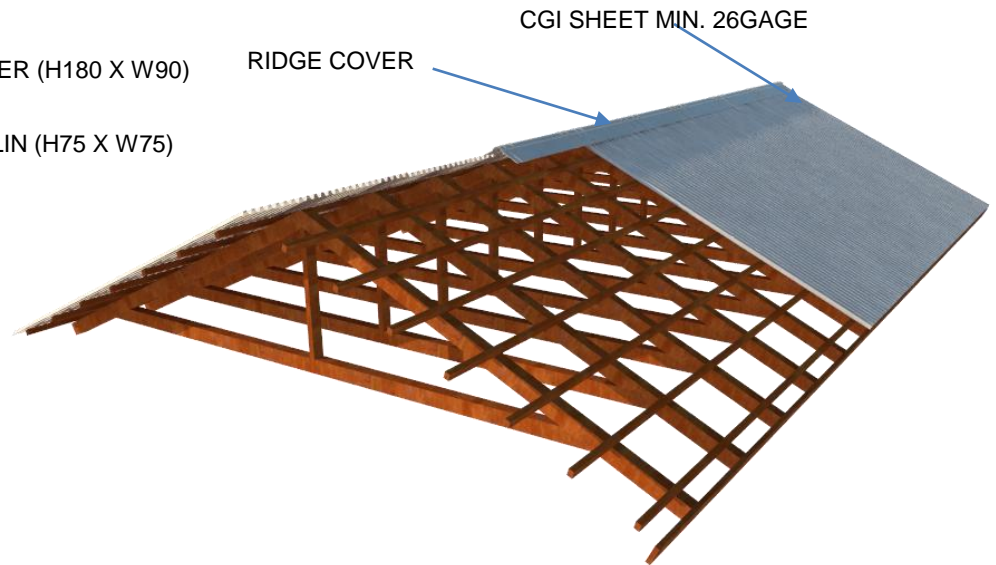

**ISOMETRIC VIEW**

CGI SHEET MIN. 26GAGE

RIDGE COVER

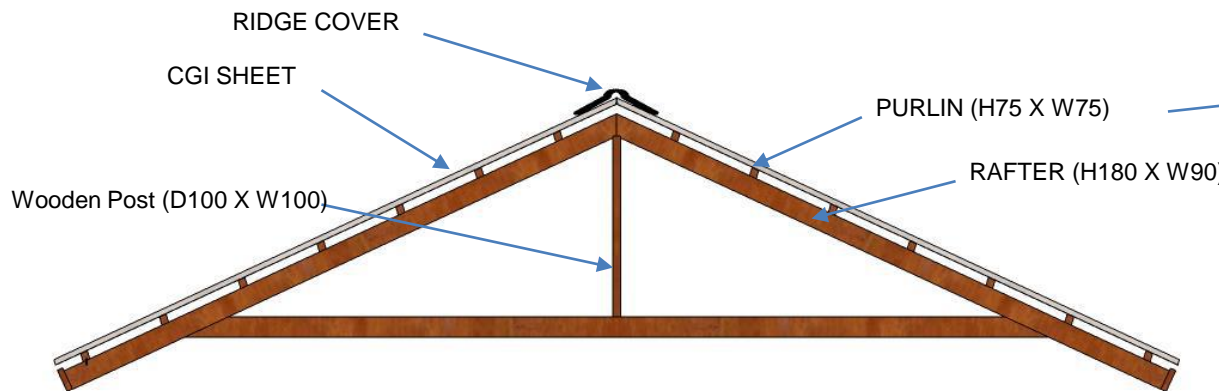

**SIDE VIEW**

RIDGE COVER  
CGI SHEET

PURLIN (H75 X W75)

RAFTER (H180 X W90)

Wooden Post (D100 X W100)

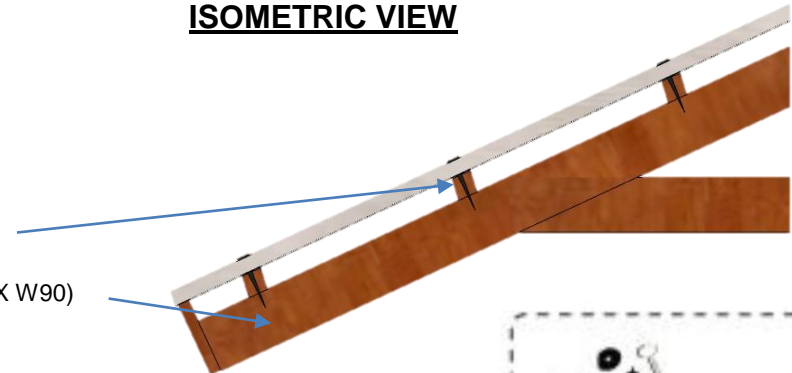

**DETAILS**

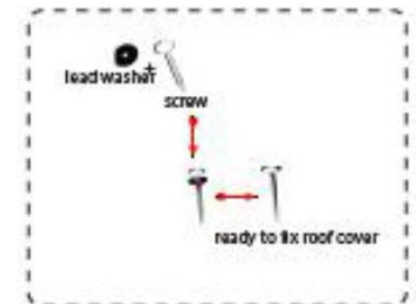

MINISTRY OF URBAN DEVELOPMENT  
DEPARTMENT OF URBAN DEVELOPMENT AND  
BUILDING CONSTRUCTION

HOUSING TYPE: R.T.B.-7.1

DRAWING TITLE: ROOF DETAILS

SCALE: NONE

DATE:

RTB-7.1

8/10

# MODEL RTB-7.1, RAT TRAP BOND MASONRY

ONE STOREY

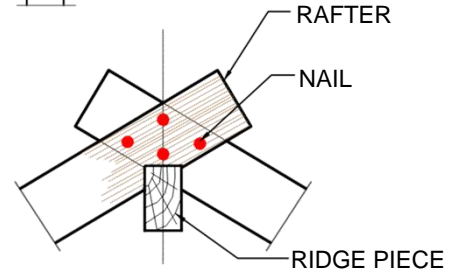
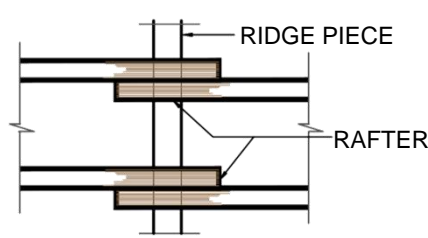
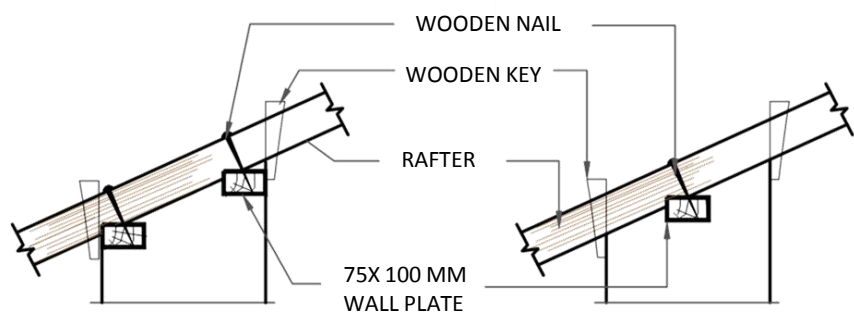
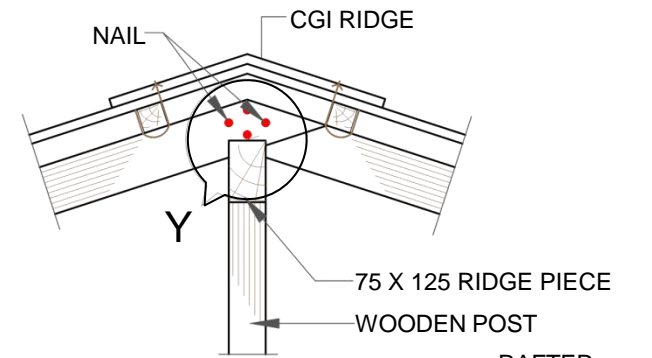
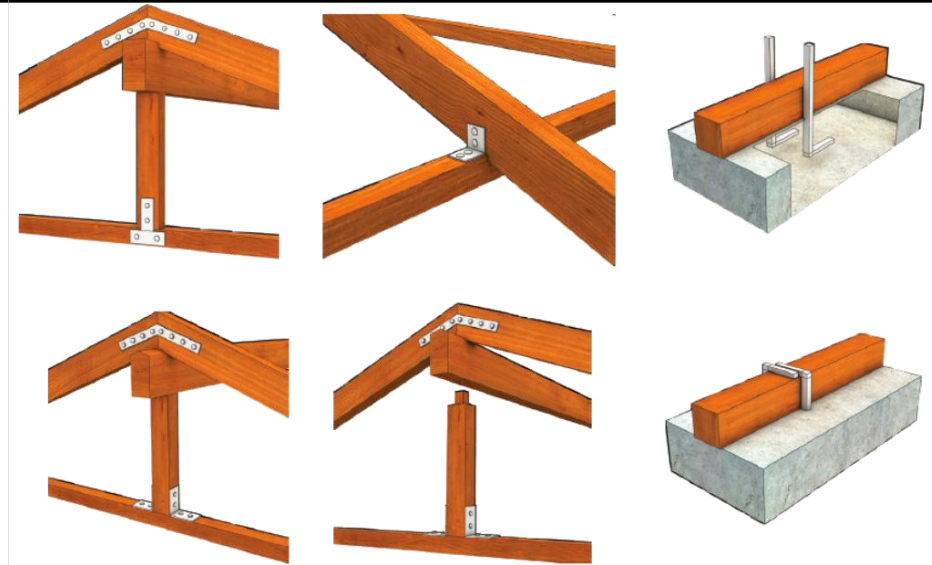
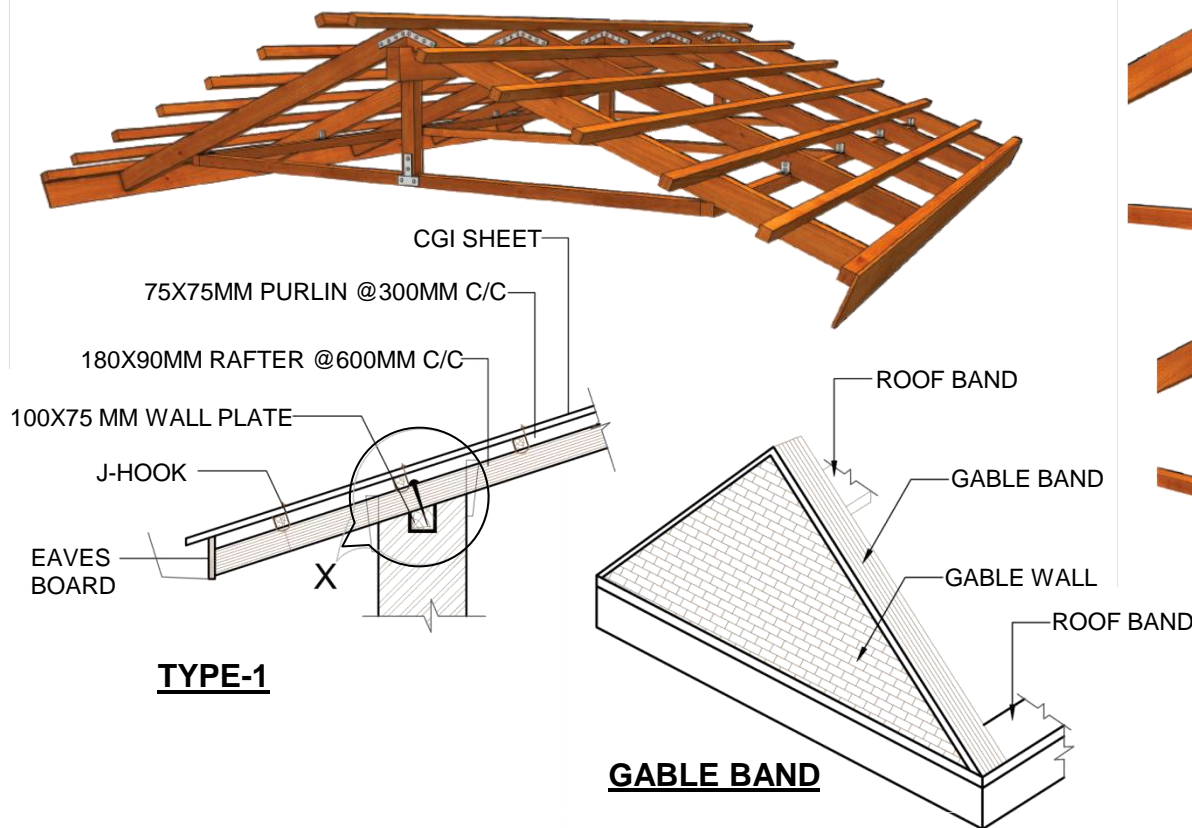

**DETAIL AT-X**

**PLAN**

**DETAIL AT-Y**



MINISTRY OF URBAN DEVELOPMENT  
DEPARTMENT OF URBAN DEVELOPMENT AND  
BUILDING CONSTRUCTION

HOUSING TYPE: R.T.B.-7.1

DRAWING TITLE: ROOF DETAILS

SCALE: NONE

DATE:

RTB-7.1

9/10

**TECHNICAL REQUIREMENTS**

<b>Structure System</b>	Load bearing Rat Trap Bond (RTB) masonry structure.
<b>Foundation</b>	Stone masonry strip footing of width 800 mm and depth 800 mm in cement sand mortar 1:4.
<b>Plinth Band</b>	RCC (1:1.5:3) plinth band shall be provided throughout the entire wall at plinth level. The minimum depth of the band shall be 150mm. Main reinforcement shall be 4 nos.12mm dia. bars with 7mm Ø stirrups at 150mm C/C.
<b>Wall System</b>	Rat trap bond brick masonry in 1:4 cement sand mortar.
<b>Sill Band</b>	RCC (1:1.5:3) sill band shall be provided throughout the entire wall at the bottom level of the openings. The minimum depth of the band shall be 75mm. Main reinforcement shall be 2 nos.12mm dia. bars with 7mm Ø stirrups at 150mm C/C.
<b>Lintel Band:</b>	RCC (1:1.5:3) lintel band shall be provided throughout the entire wall at the bottom level of the openings. The minimum depth of the band shall be 150mm. Main reinforcement shall be 4 nos.12mm dia. bars with 7mm Ø stirrups at 150mm C/C.
<b>Roof Band:</b>	RCC (1:1.5:3) roof band shall be provided throughout the entire wall at roof level. The minimum depth of the band shall be 150mm. Main reinforcement shall be 4 nos.12mm dia. bars with 7mm Ø stirrups at 150mm C/C.
<b>Roof:</b>	Lightweight roof of corrugated iron sheet over wooden truss. All joints in the truss shall be properly connected as shown in the drawing.



# EARTHBAG MASONRY

**E.B.-8.1**

Earthbag technology is a simple, inexpensive and sustainable method for building structures using ordinary soil found at construction site. The technology consists of Polypropylene bags filled with locally available soil, laid similarly to masonry with barbed wire serving as a mortar and provides tensile as well as shear strength. The featured design of Earthbag technology EB 8.1 consists of single storied structure with two rooms. The wall system uses Polypropylene bags filled with soil whereas CGI sheet is used for covering the roof along with wooden rafters and purlins.

### **MATERIAL PROPERTIES**

Soil for Earthing: 25% - 30% clay & 70% - 75% Sandy soil

Bags: Polypropylene bags

Barbed wire: 14guage, 4 pointed

Rebar: Mild steel bar of Grade Fe 250

Nominal Mix Ratio : 1:1.5:3 (C:S:A)

# **E.B.-8.1**

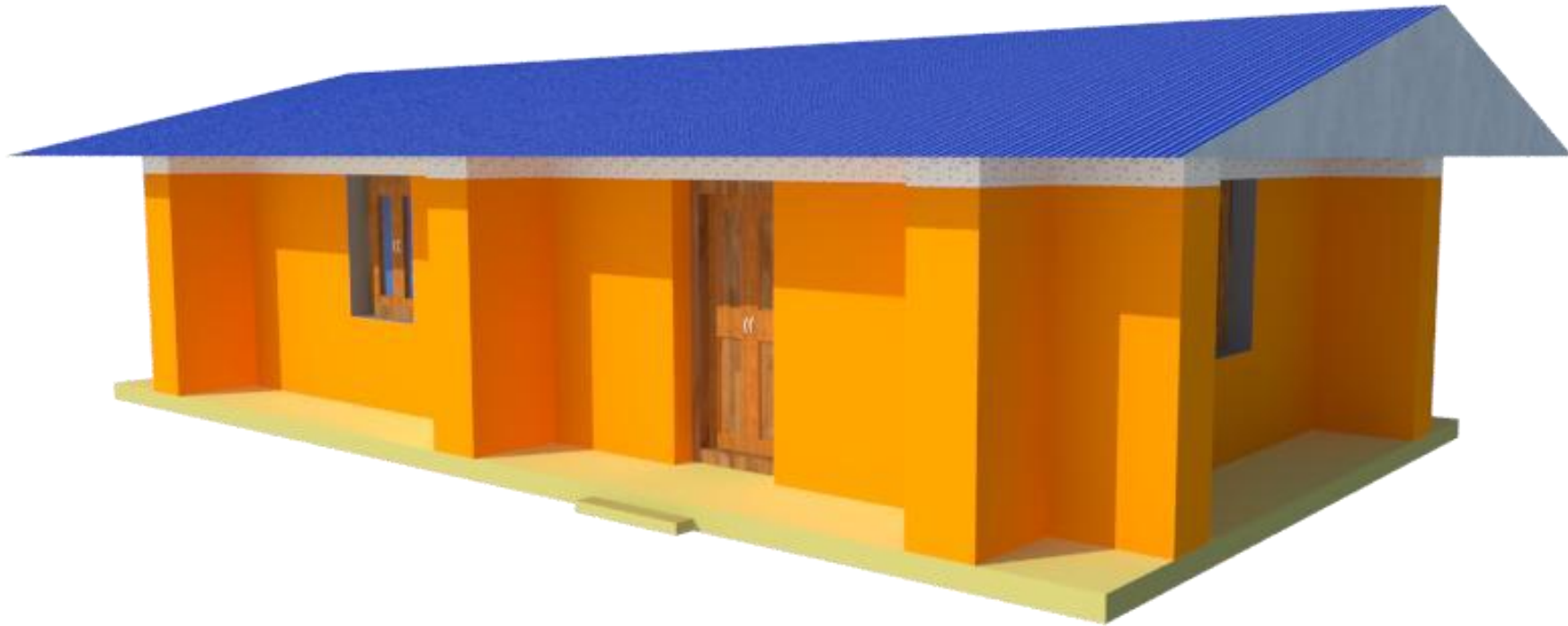

LEVEL	MATERIALS								
	Stone	Cement	Sand	Aggregate	Reinforcing Bar	CGI Sheet	GI Sheet	Wood	Earth
	Cu.m.	Bags	Cu.m.	Cu.m.	Kg.	Bundle	Sq.m.	Cu.m.	Cu.m.
Up to Plinth Level	12.3	-	-	-	-			-	-
Super Structure	-	19	1.0	2.0	237.3			0.5	25.5
Roofing	-	-	-	-	-	4.2	8.0	2.4	
<b>TOTAL</b>	<b>12.3</b>	<b>19</b>	<b>1.0</b>	<b>2.0</b>	<b>237.3</b>	<b>4.2</b>	<b>8.0</b>	<b>2.9</b>	<b>25.5</b>





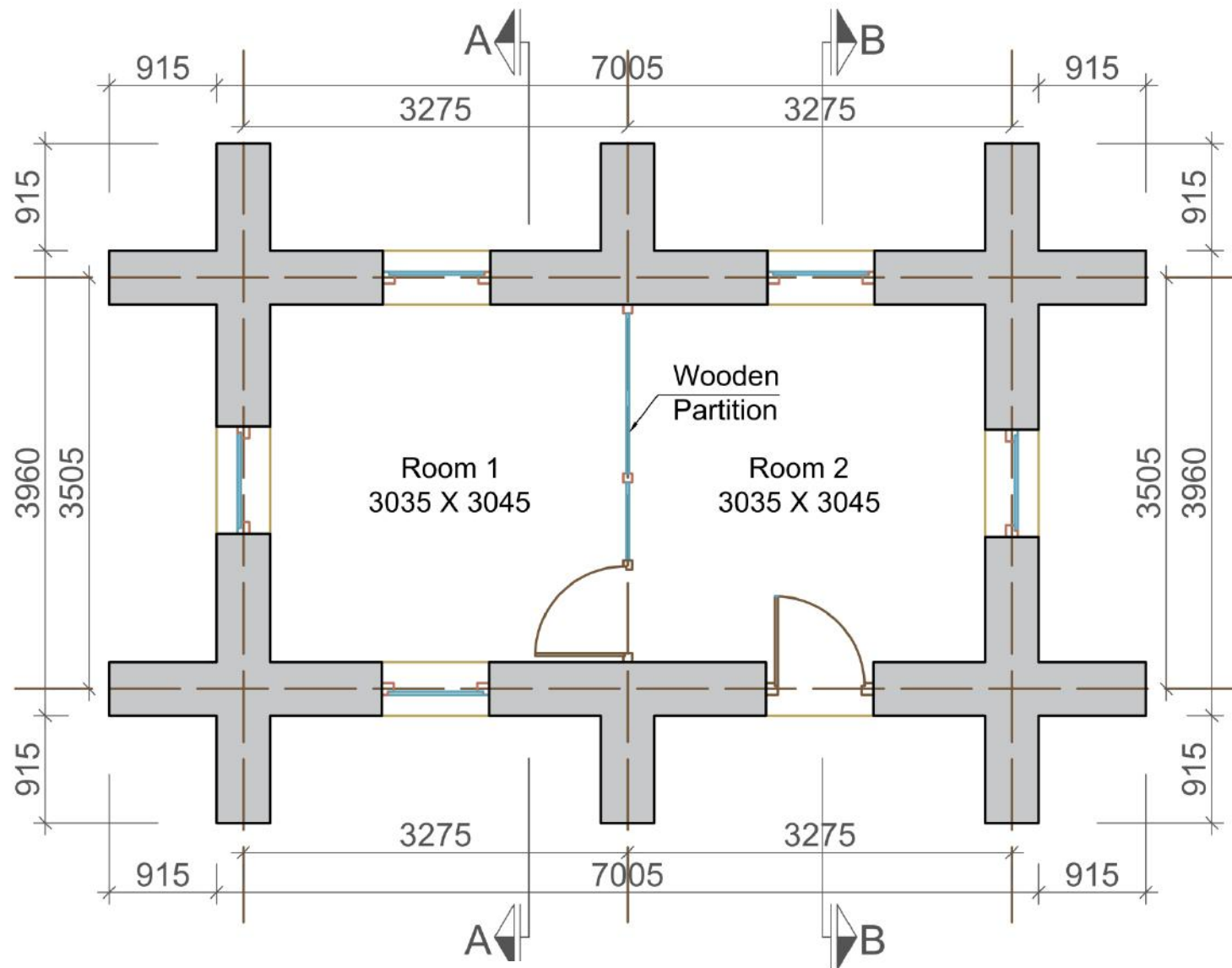

**GROUND FLOOR PLAN**

FLOOR AREA: 31.95 SQ.M.



MINISTRY OF URBAN DEVELOPMENT  
DEPARTMENT OF URBAN DEVELOPMENT AND  
BUILDING CONSTRUCTION

HOUSING TYPE: MODEL E.B.-8.1

DRAWING TITLE: FLOOR PLAN

SCALE: NONE

DATE:

E.B.-8.1  
2/11



**FRONT ELEVATION**



**SIDE ELEVATION**



**BACK ELEVATION**



**SIDE ELEVATION**



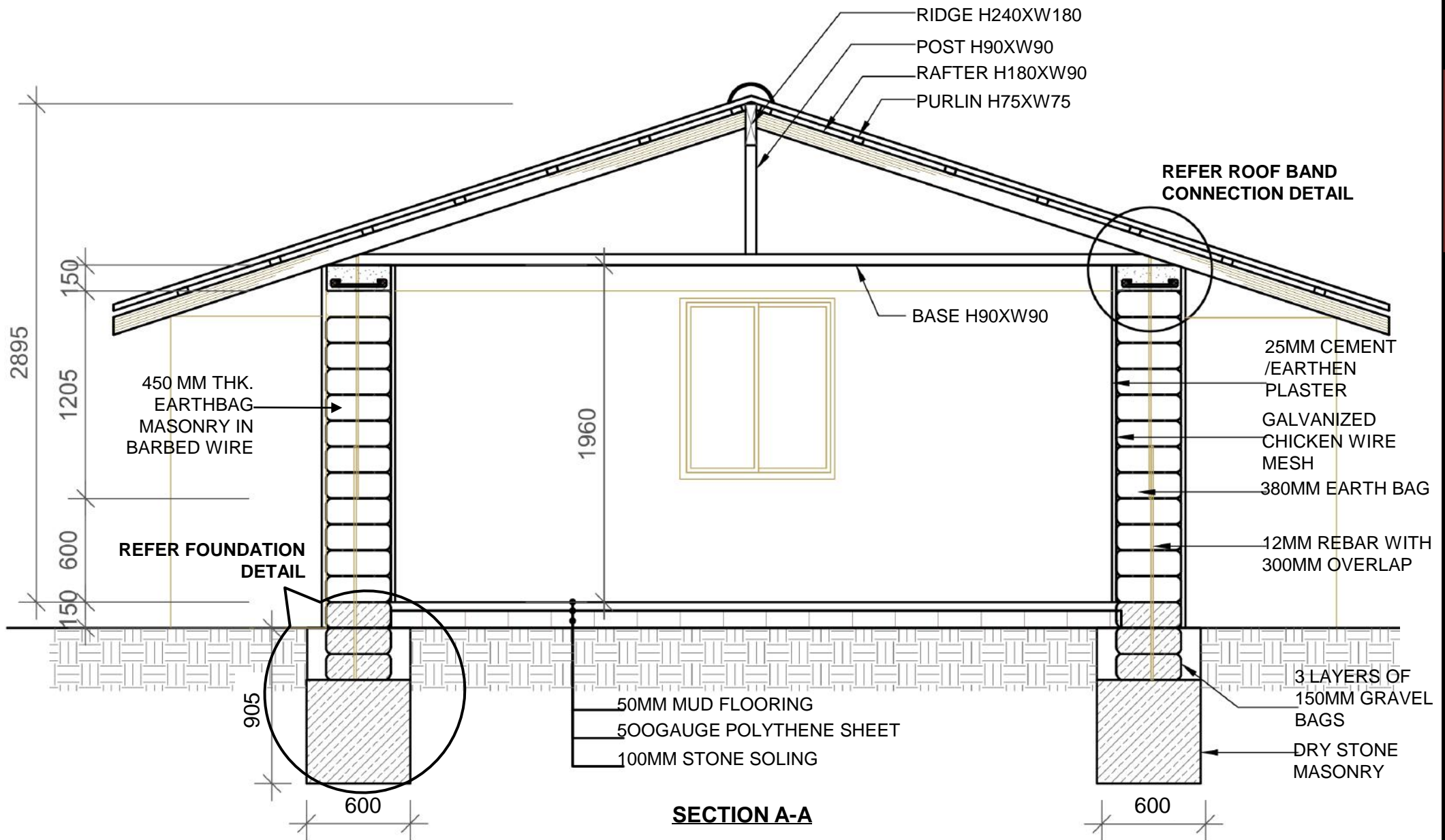

SECTION A-A



MINISTRY OF URBAN DEVELOPMENT  
DEPARTMENT OF URBAN DEVELOPMENT AND  
BUILDING CONSTRUCTION

HOUSING TYPE: MODEL E.B.-8.1

DRAWING TITLE: SECTION

SCALE: NONE

DATE:

E.B.-8.1  
4/11

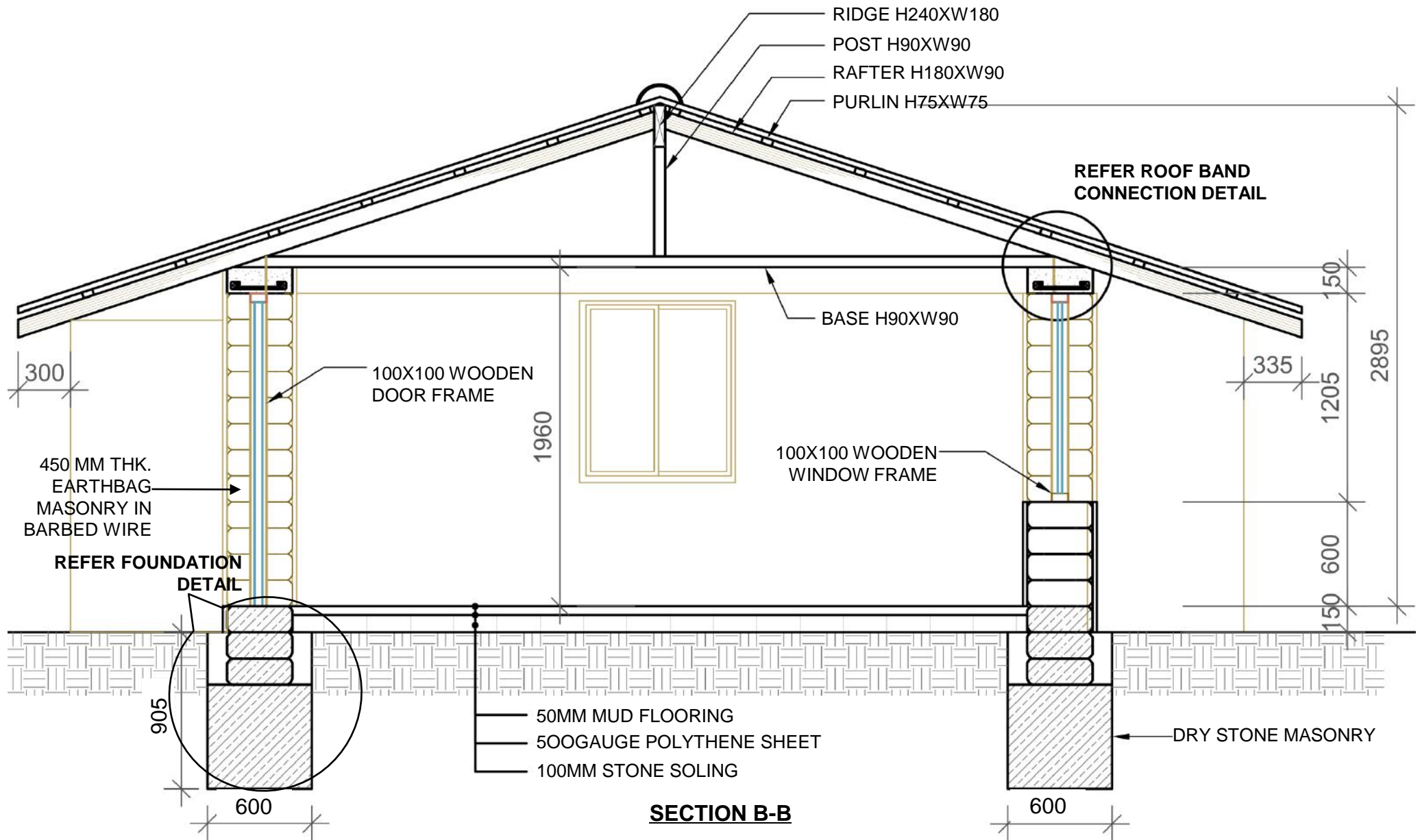

MINISTRY OF URBAN DEVELOPMENT  
 DEPARTMENT OF URBAN DEVELOPMENT AND  
 BUILDING CONSTRUCTION

HOUSING TYPE: MODEL E.B.-8.1

DRAWING TITLE: SECTION

SCALE: NONE

DATE:

E.B.-8.1  
 5/11

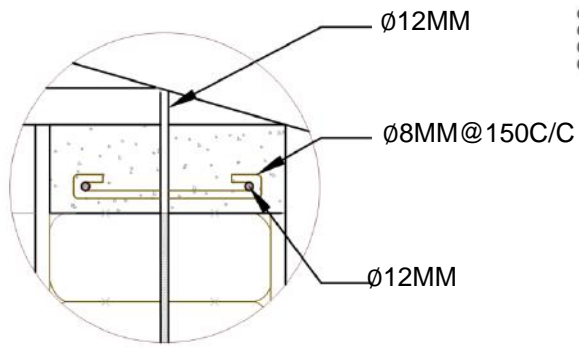

**ROOF BAND CONNECTION WITH TRUSS**

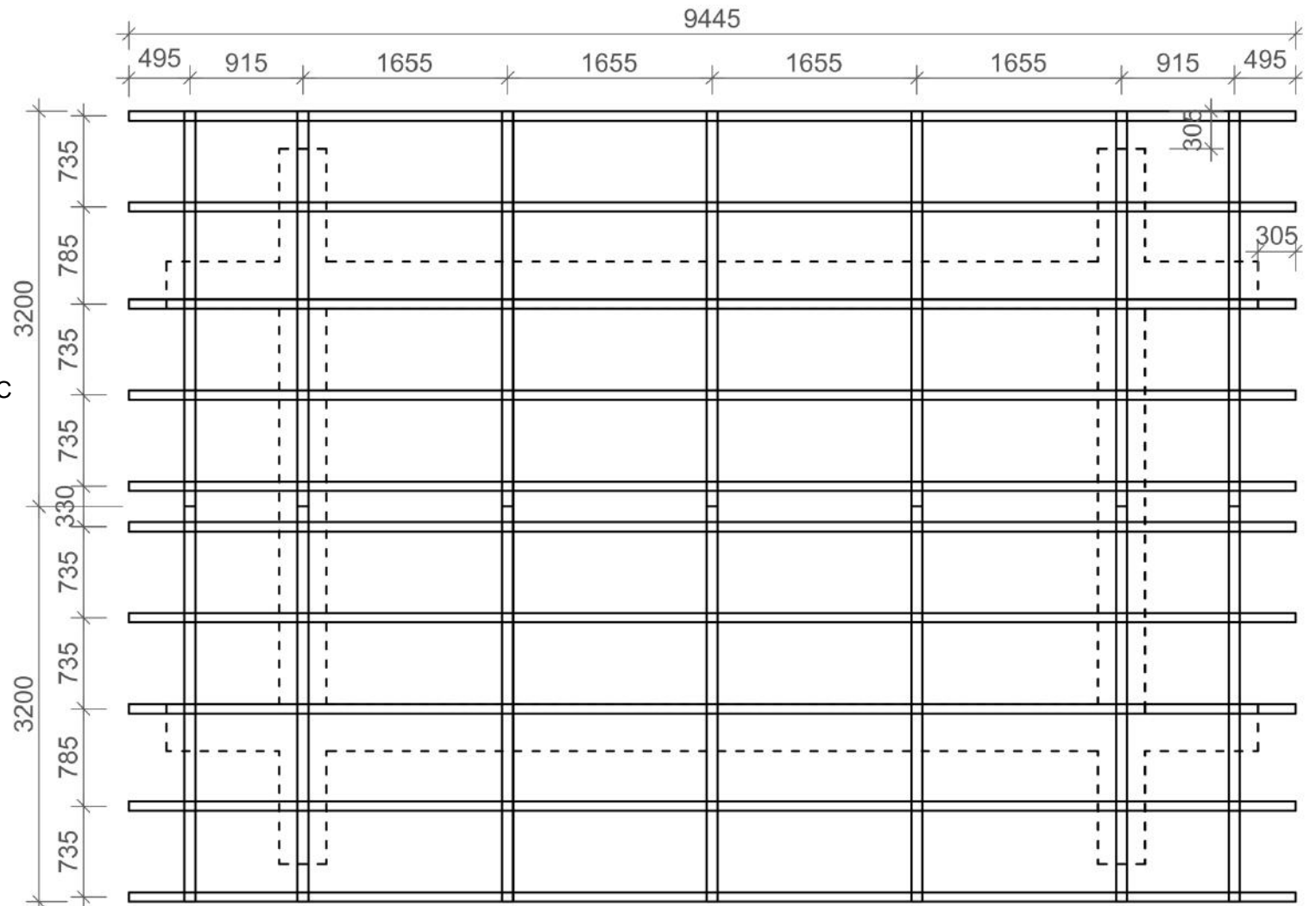

**ROOF PLAN**



MINISTRY OF URBAN DEVELOPMENT  
DEPARTMENT OF URBAN DEVELOPMENT AND  
BUILDING CONSTRUCTION

HOUSING TYPE: MODEL E.B.-8.1

DRAWING TITLE: ROOF DETAILS

SCALE: NONE

DATE:

E.B.-8.1  
6/11

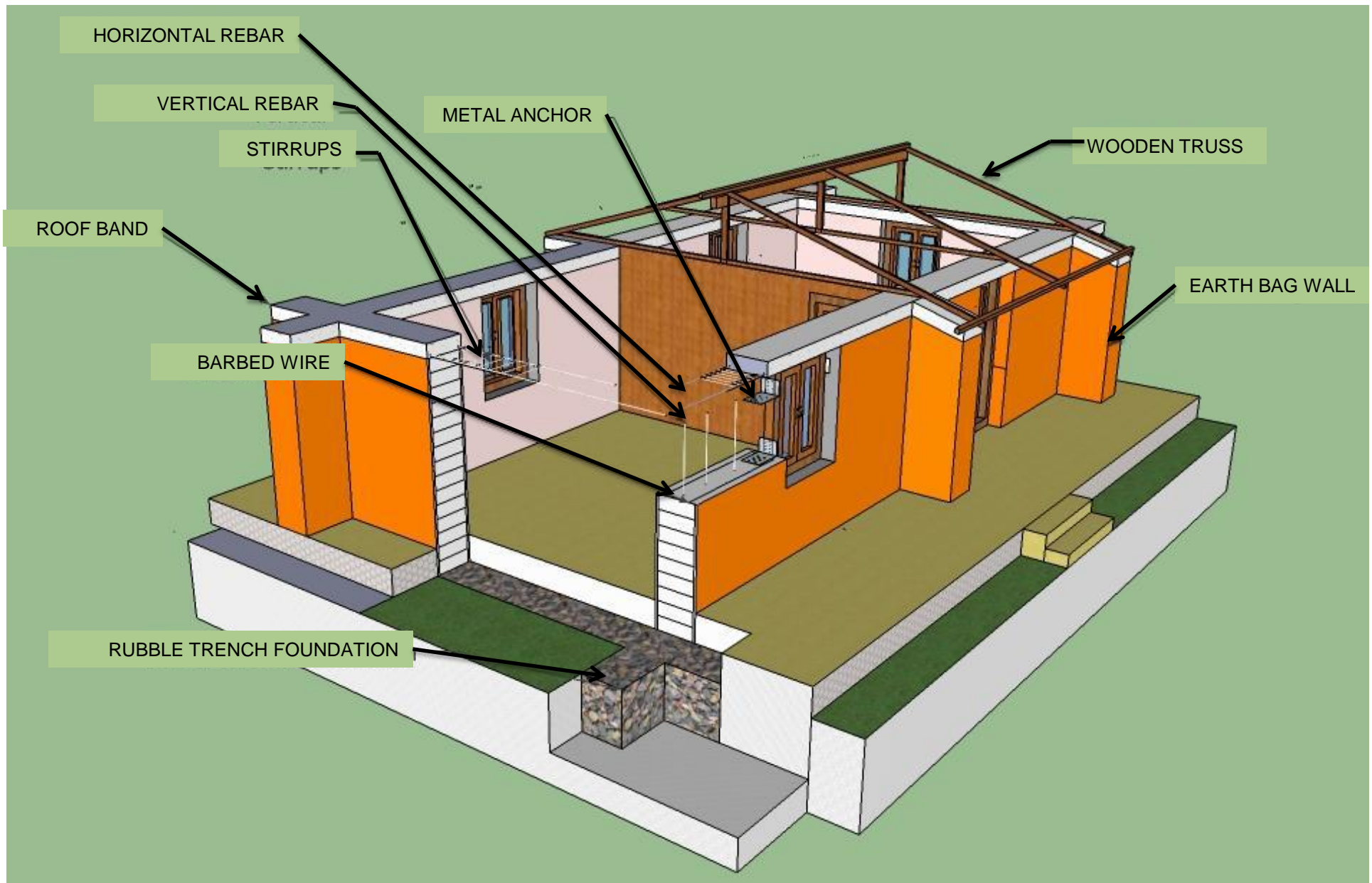

MINISTRY OF URBAN DEVELOPMENT  
DEPARTMENT OF URBAN DEVELOPMENT AND  
BUILDING CONSTRUCTION

HOUSING TYPE: MODEL E.B.-8.1

DRAWING TITLE: SECTIONAL PERSPECTIVE

SCALE: NONE

DATE:

E.B.-8.1  
7/11

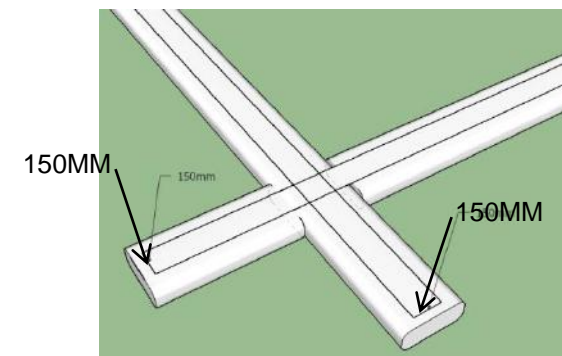
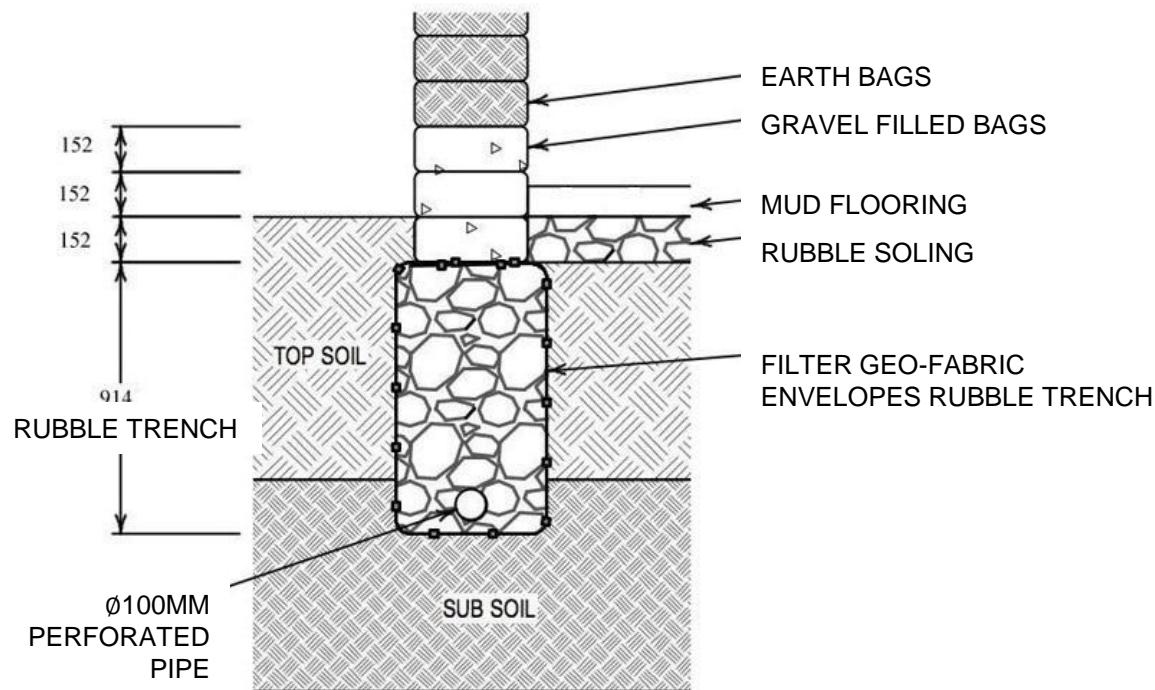

**BARBED WIRE SHOULD BE LAID CENTRALLY WITH A MINIMUM GAP OF 150MM AS SHOWN IN THE FIGURE ABOVE**

**BASE WIDTH OF FOOTING = 200 + 1 BAG WIDTH**

**FOUNDATION SECTION**



**CONSTRUCTION SEQUENCE**

- 1 SURVEY THE SITE AND SAMPLE THE SOIL. GET ADVICE FROM AN ENGINEER

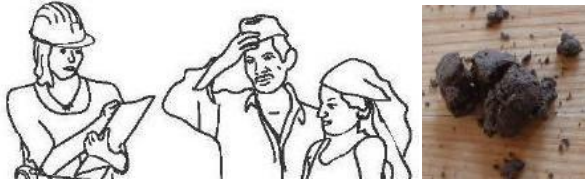

- 4 BUILD RUBBLE TRENCH FOUNDATION  
INSTALL FRENCH DRAIN & PLUMBING

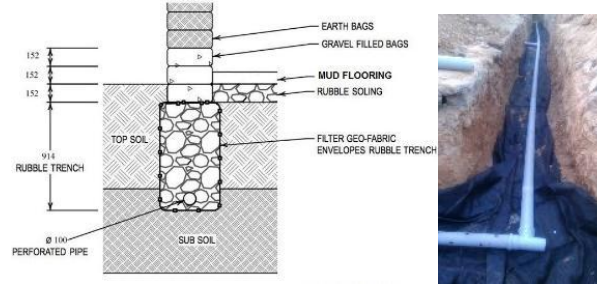

- 7 LAY SECOND OR THIRD GRAVEL BAG LAYER ABOVE FLOOR LEVEL



- 2 LEVEL THE BUILDING SITE AND COVER WITH TARP TO PROTECT BAGS FROM RAIN & SUN



- 5 FILL AND PLACE FIRST COURSE OF GRAVEL BAGS



- 8 USE SLIDERS AND ALWAYS OVERLAP THE BAGS WHILE BUILDING THE WALL

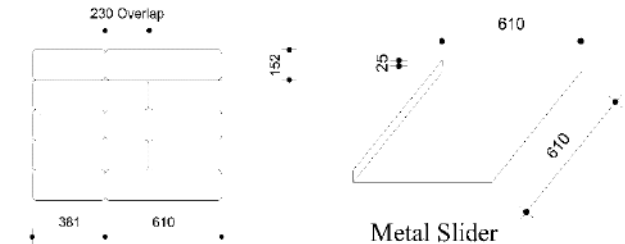

- 3 MARK THE FOOTPRINT, INCLUDING CORNER & WALL BUTTRESSES, EXCAVATE TRENCH 3FT DEEP, 2FT WIDE

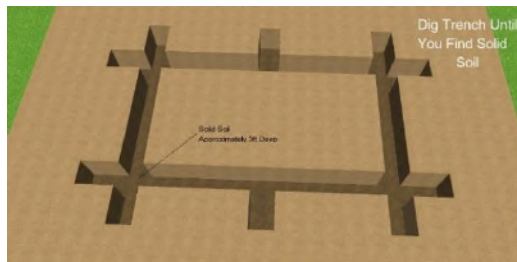

- 6 LAY TWO STRANDS OF 4-POINT BARBED WIRE ON TOP OF EACH COURSE AND ADD WALL TIES



- 9 MAKE DOOR THRESHOLDS, INSTALL DOOR FRAMES AND OPTIONAL DOOR BUCKS

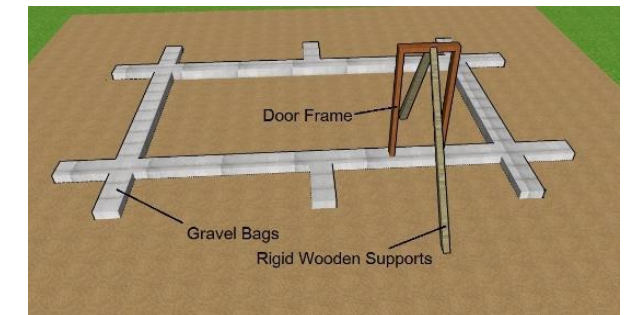



**CONSTRUCTION SEQUENCE**

**10** PREPARE SOIL FOR EARTH BAGS:  
SIEVE AND MAINTAIN 10% MOISTURE



**14** TAMP, LEVEL AND FLATTEN WALLS  
AFTER EACH COURSE



**17** USE ANCHOR PLATES TO ATTACH DOORS AND  
WINDOWS

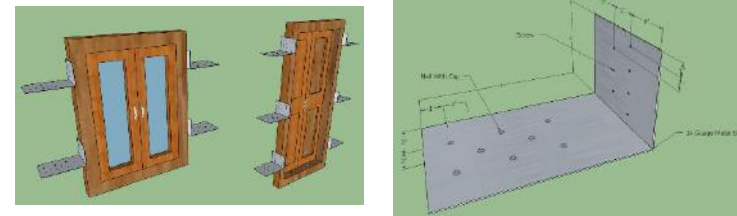

**11** FILL BAGS WITH EARTH, PLACE FIRST  
COURSE AND TAMP



**15** PLACE THE WINDOW FRAME SO THE  
LINTEL LEVEL COINCIDES WITH THE  
BOND BEAM LEVEL



**18** INSTALL GALVINIZED/PLASTIC MESH FOR  
PLASTERING



**12** REPEAT STEP 6 AFTER EACH COURSE

**13** PREVENT CORNER DROP

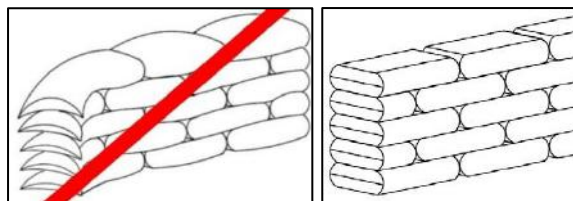

**16** INSTALL VERTICAL REBARS AT SILL  
AND LINTEL LEVEL

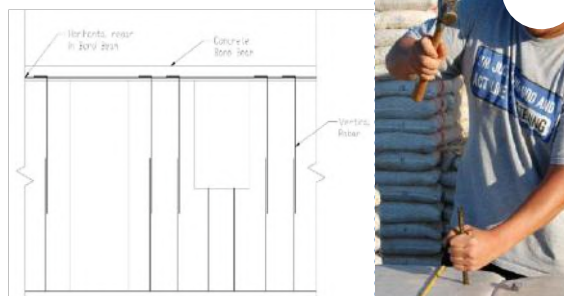

**19** INSTALL BOND BEAM, LIGHTWEIGHT ROOF AND  
ELECTRICAL WIRING



**20** PLASTER AND PAINT



**TECHNICAL REQUIREMENTS**

<b>Structure System</b>	Load bearing Earthbag masonry structure.
<b>Foundation</b>	Strip Foundation of dry stone masonry of width 600 mm and depth 900 mm.
<b>Plinth</b>	Three polypropylene bags filled with gravel shall be placed up to plinth level.
<b>Wall System</b>	450 mm thick Earthbag masonry shall be interconnected in each layers with barbed wire. Buttress shall be provided along the unsupported length of wall as shown in drawing.
<b>Roof Band:</b>	RCC (1:1.5:3) roof band shall be provided throughout the wall at roof level. The minimum depth of the band shall be 150mm. Main reinforcement shall be 2 nos.12mm dia. bars with 8mm Ø stirrups at 150mm C/C.
<b>Roof:</b>	Lightweight roof of corrugated iron sheet over wooden truss. All joints in the truss shall be properly connected as shown in the drawing.



# LIGHT GAUGE STEEL STRUCTURE

**L.G.S.-9.1**

**L.G.S.-9.2**

Cold Form Light gauge steel construction is a structural system consisting of thin steel sections clad with light gauge steel panel, Cellular light weight concrete, Cement fiber board, gypsum board or calcium silicate board. The steel sections used here are called *cold formed* sections, meaning that the sections are formed, or given shape at room temperature. This kind of technology requires high level of planning and precision as cold formed sections are fabricated at factory. Similarly skilled manpower are required in site for precise execution of designs. Featured design L.G.S 9.1 is a single storied residential unit with 2 bedrooms. Model L.G.S 9.2 is a two storied residential units with 4 bedrooms.

### **MATERIAL PROPERTIES**

The raw materials used for the LGS steel frame is Galvanized cold form steel stripe

Yield strength:

Min. 450 N/mm<sup>2</sup> for LGS 9.1

Min. 350 N/mm<sup>2</sup> for LGS-9.2

Galvanized zinc coated: Min. 275gsm

# L.G.S.-9.1

# L.G.S.-9.2



LEVEL	MATERIALS								
	Stone	Brick	Cement	Sand	Aggregate	Reinforcing Bar	CGI Sheet	GI Sheet	MS angles & Plates
	Cu.m.	No.	Bags	Cu.m.	Cu.m.	Kg.	Bundle	Sq.m.	Cu.m.
<b>Up to Plinth Level</b>	42.1	15,702.0	115.5	13.0	11.1	468.5			-
<b>Super Structure</b>		-	2.5	0.3	-	-			4,184.8
<b>Roofing</b>		-	-	-	-	-	8.8	32.9	1,753.2
<b>TOTAL</b>	<b>42.1</b>	<b>15,702.0</b>	<b>118</b>	<b>13.3</b>	<b>11.1</b>	<b>468.5</b>	<b>8.8</b>	<b>32.9</b>	<b>5,938.0</b>



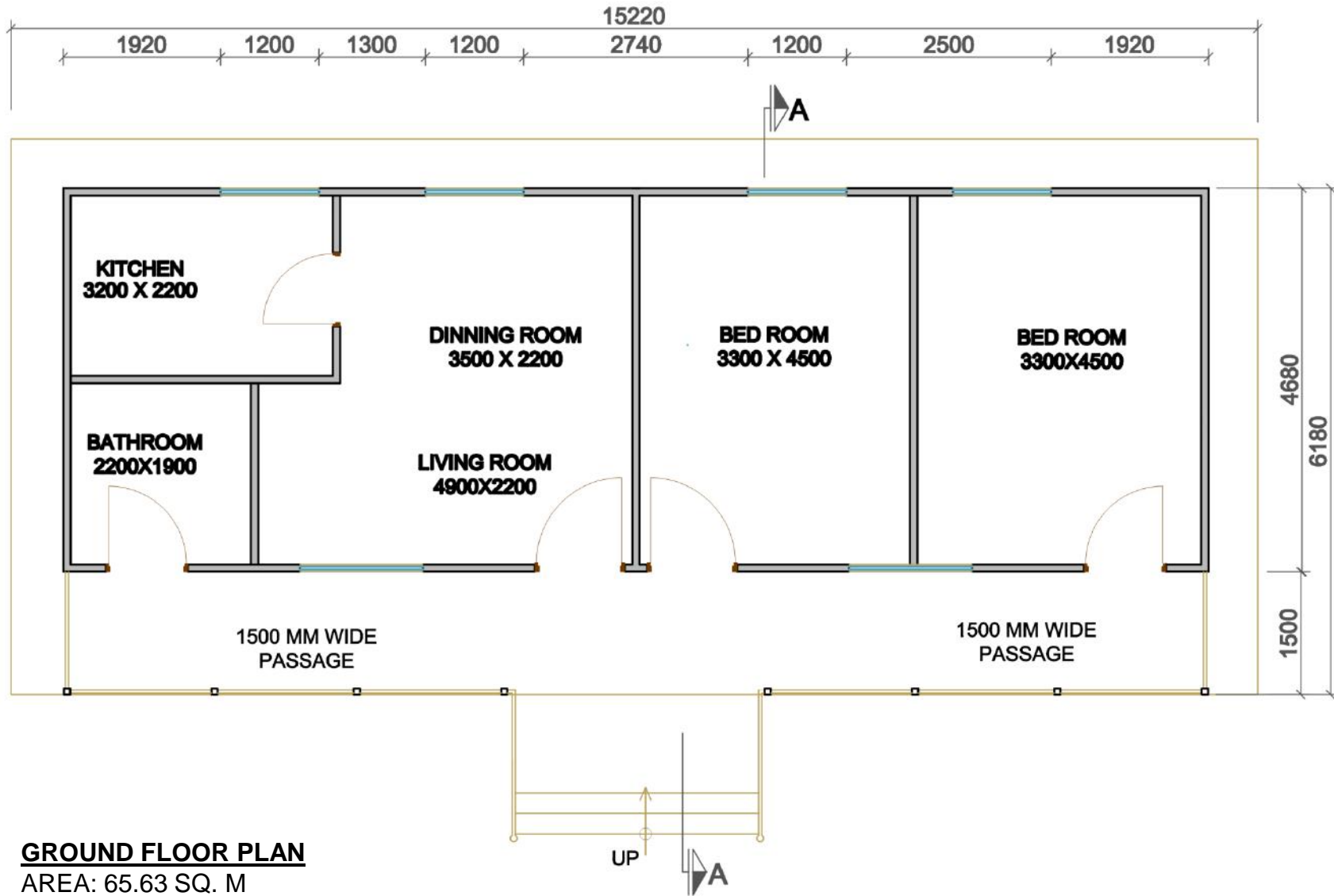

MINISTRY OF URBAN DEVELOPMENT  
DEPARTMENT OF URBAN DEVELOPMENT AND  
BUILDING CONSTRUCTION

HOUSING TYPE: MODEL L.G.S.-9.1

DRAWING TITLE: FLOOR PLAN

SCALE: NONE

DATE:

L.G.S 9.1  
2/9

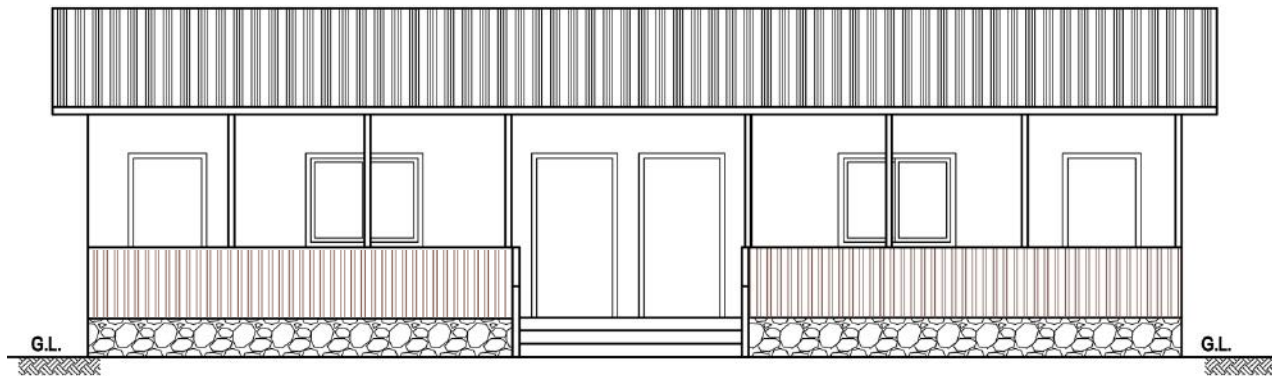

**FRONT ELEVATION**

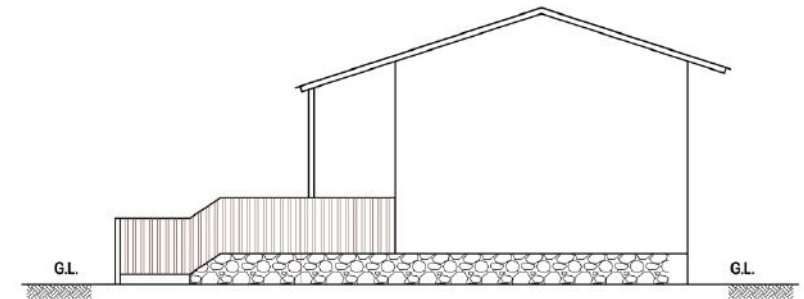

**SIDE ELEVATION**

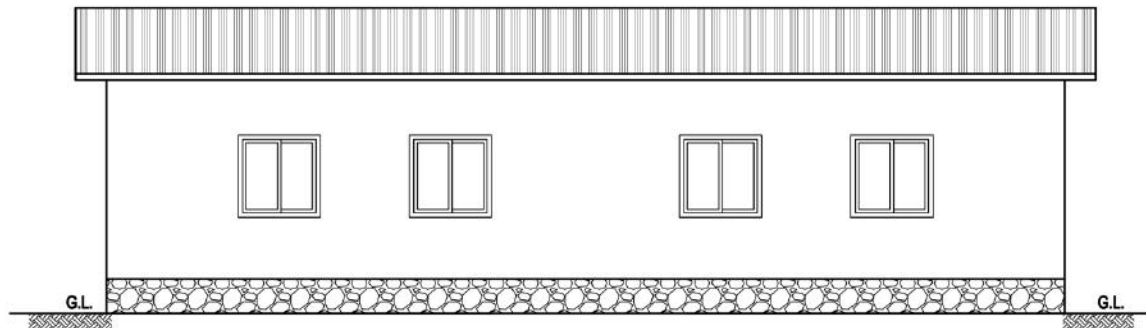

**BACK ELEVATION**

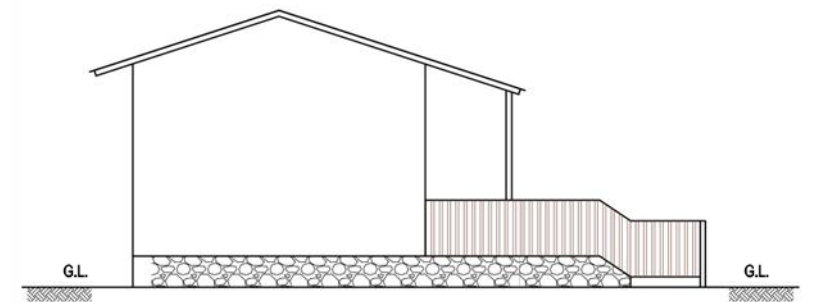

**SIDE ELEVATION**



**MINISTRY OF URBAN DEVELOPMENT  
DEPARTMENT OF URBAN DEVELOPMENT AND  
BUILDING CONSTRUCTION**

**HOUSING TYPE: MODEL L.G.S.-9.1**

**DRAWING TITLE: ELEVATIONS**

**SCALE: NONE**

**DATE:**

**L.G.S 9.1  
3/9**

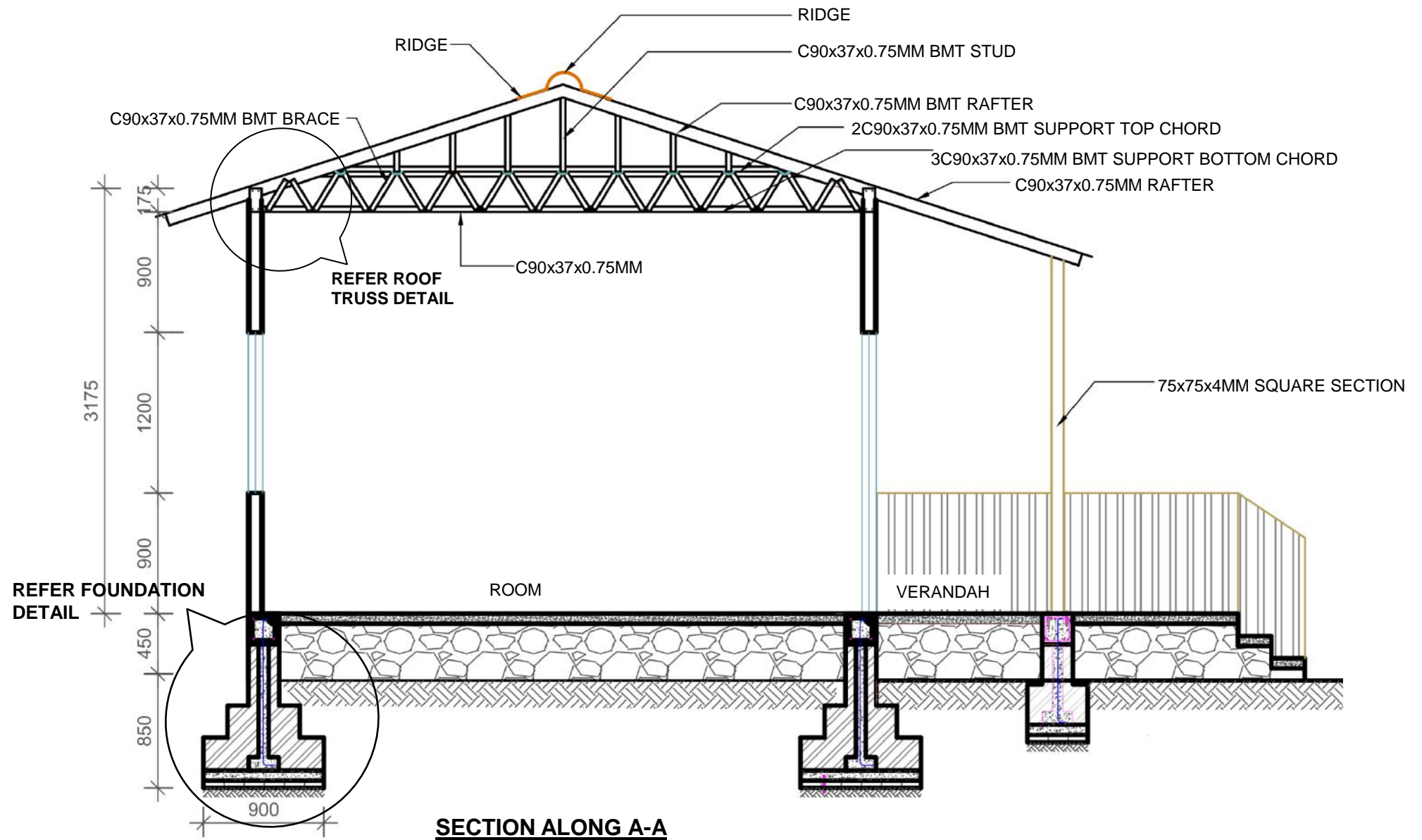

MINISTRY OF URBAN DEVELOPMENT  
DEPARTMENT OF URBAN DEVELOPMENT AND  
BUILDING CONSTRUCTION

HOUSING TYPE: MODEL L.G.S.-9.1

DRAWING TITLE: SECTION

SCALE: NONE

DATE:

L.G.S 9.1  
4/9



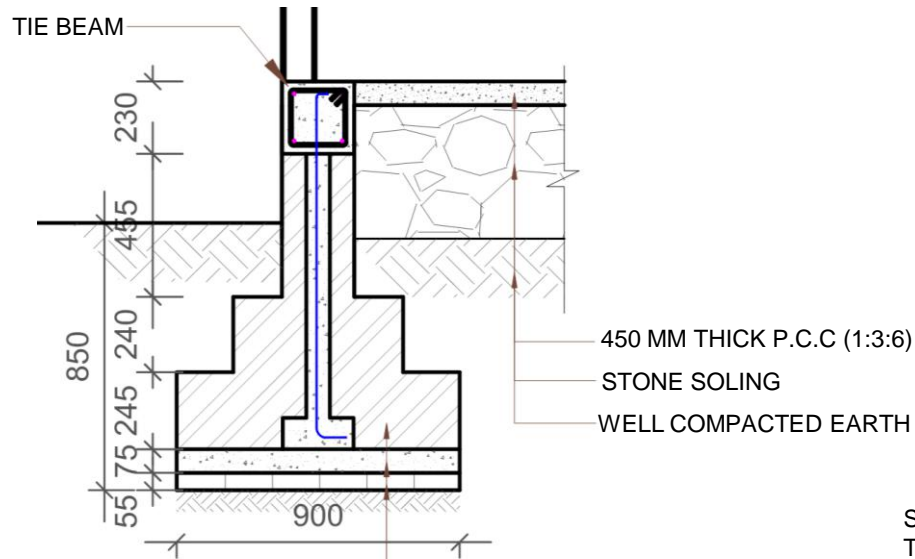

**FOUNDATION SECTION**

75MM THICK P.C.C (1:3:6)  
 ONE LAYER FLAT BRICK SOLING  
 WELL COMPACTED EARTH

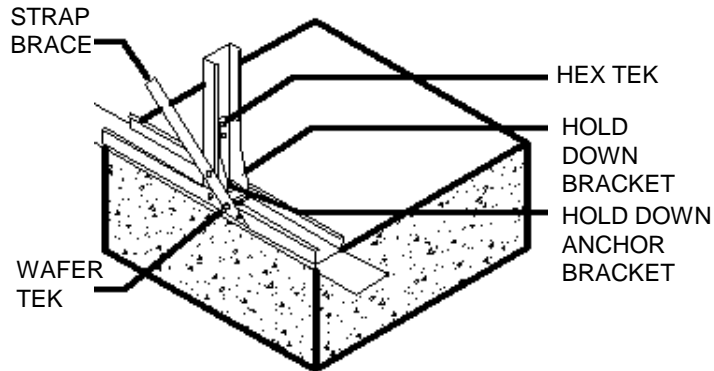

**CONNECTION DETAILS AT DPC LEVEL**

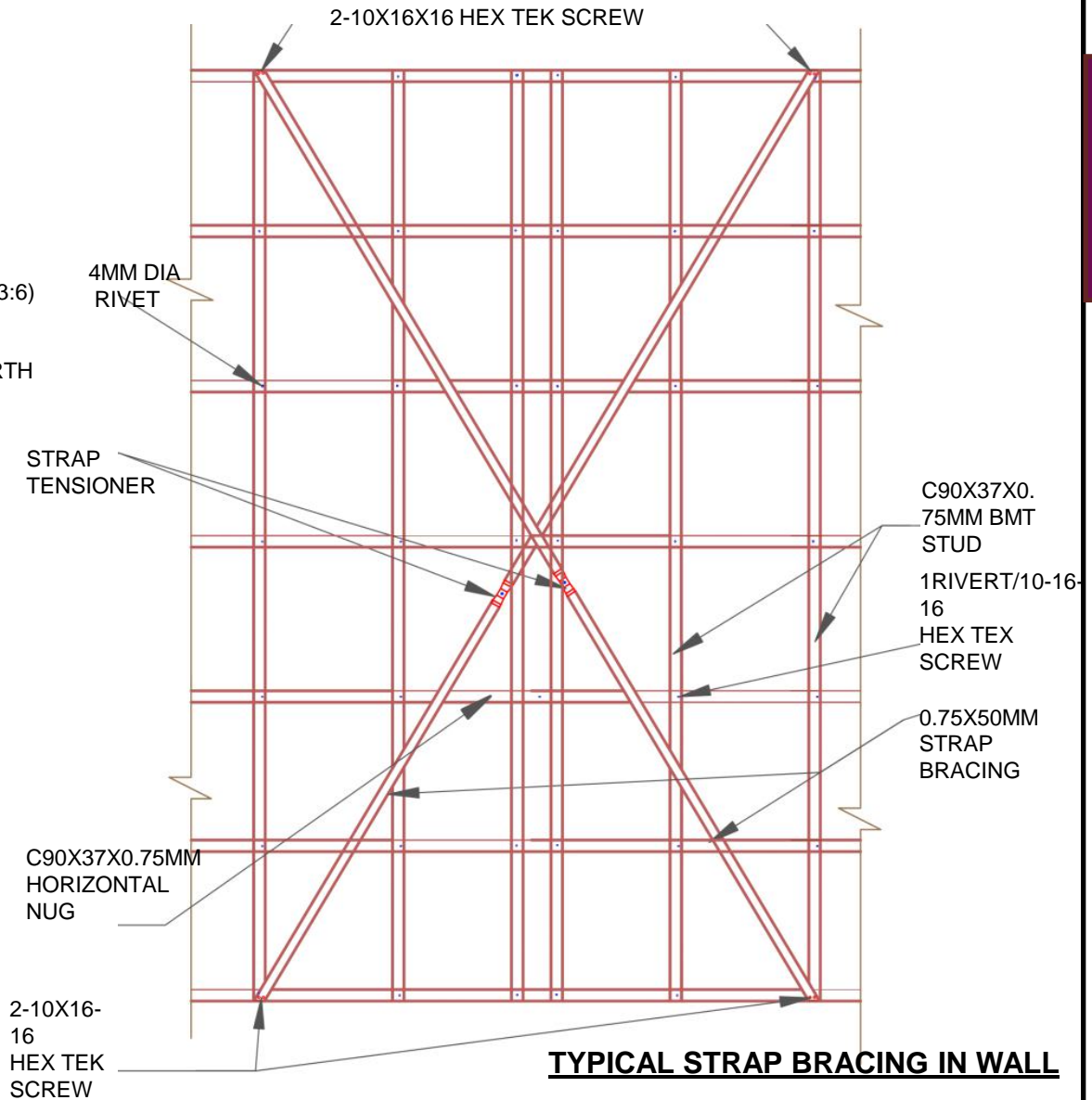

**TYPICAL STRAP BRACING IN WALL**



MINISTRY OF URBAN DEVELOPMENT  
 DEPARTMENT OF URBAN DEVELOPMENT AND  
 BUILDING CONSTRUCTION

**HOUSING TYPE: MODEL L.G.S.-9.1**

**DRAWING TITLE: DETAILS**

**SCALE: NONE**

**DATE:**

**L.G.S 9.1**

**5/9**

# MODEL L.G.S.-9.1, LIGHT GAUGE STEEL STRUCTURE

ONE STOREY

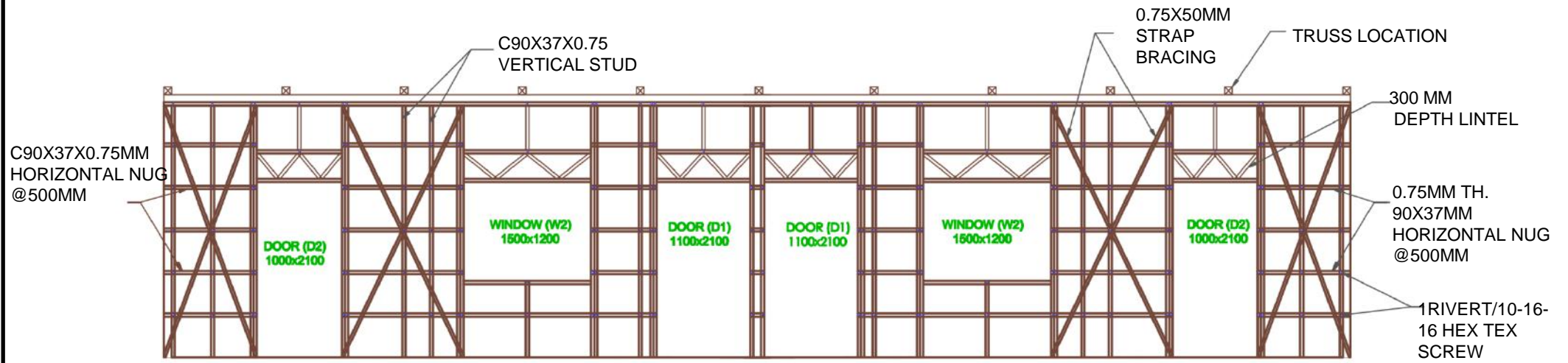

**STRUCTURAL ELEVATION 1**

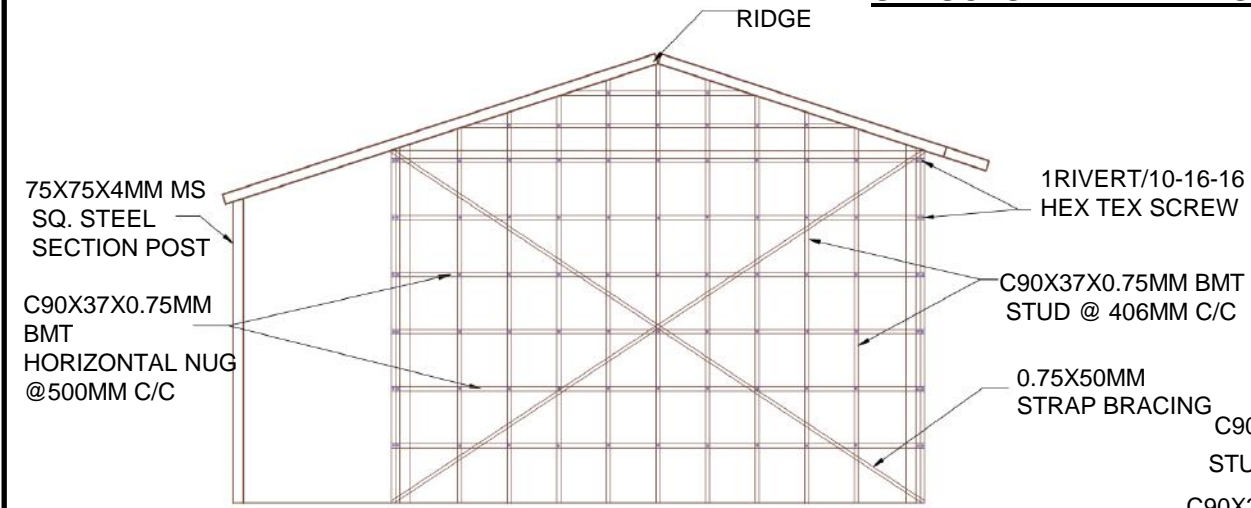

**STRUCTURAL ELEVATION 2**

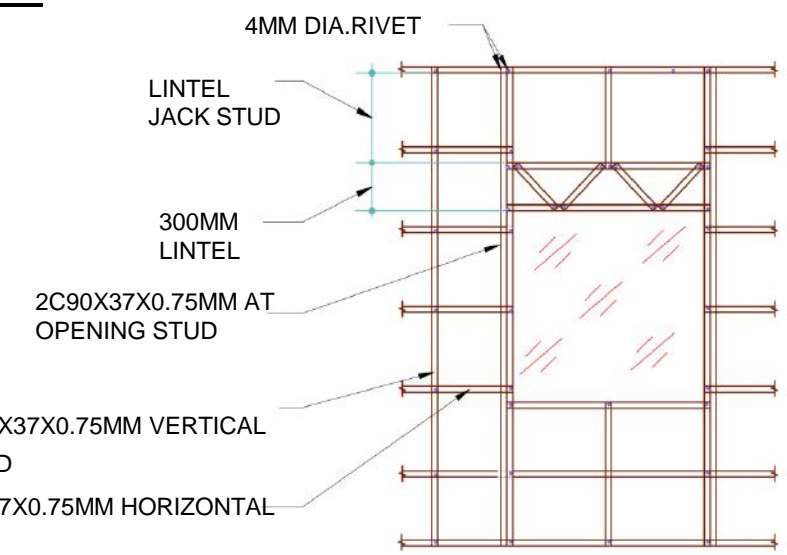

**TYPICAL ELEVATION DETAIL AT OPENING**

ALL SECTIONS C90X37X0.95MM BMT

 <p>MINISTRY OF URBAN DEVELOPMENT DEPARTMENT OF URBAN DEVELOPMENT AND BUILDING CONSTRUCTION</p>	HOUSING TYPE: MODEL L.G.S.-9.1	SCALE: NONE	L.G.S 9.1 6/9
	DRAWING TITLE: DETAILS	DATE:	

# MODEL L.G.S.-9.1, LIGHT GAUGE STEEL STRUCTURE

ONE STOREY

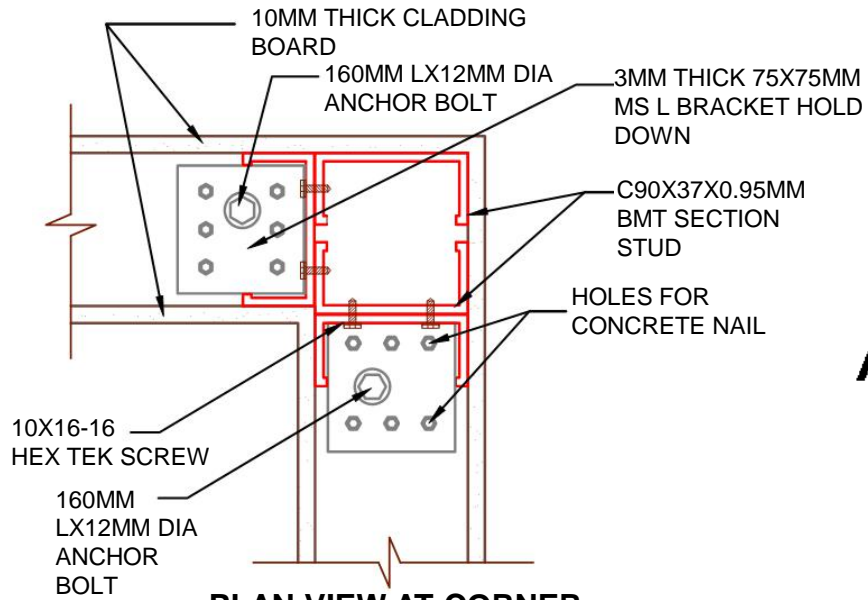

**PLAN VIEW AT CORNER**

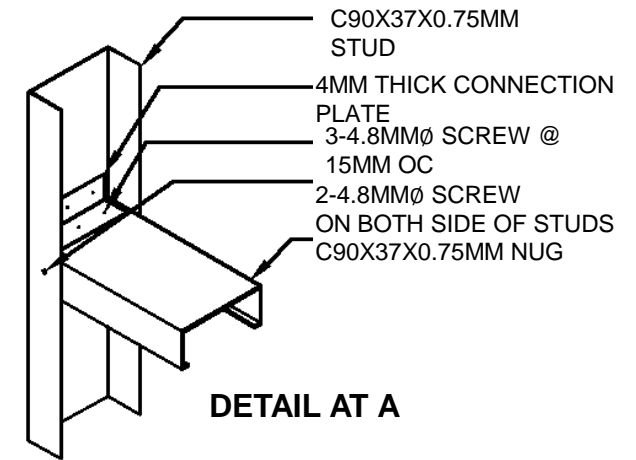
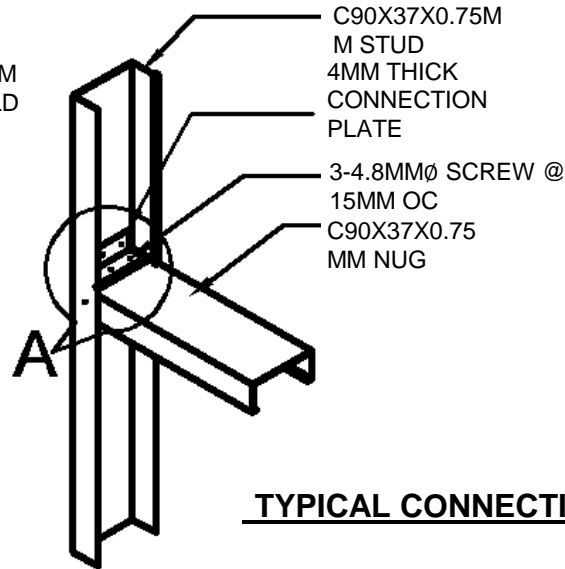

**DETAIL AT A**

**TYPICAL CONNECTION DETAILS OF STUD AND NUG.**

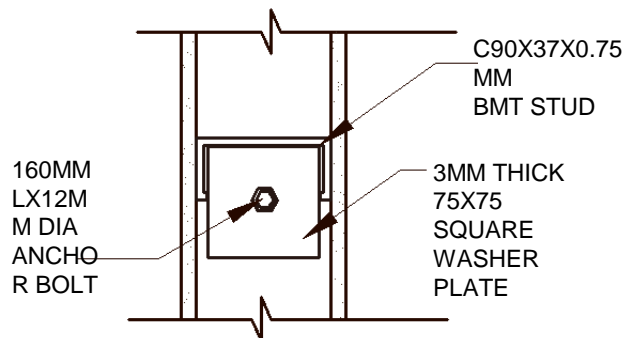

**PLAN VIEW AT WALL STUD**

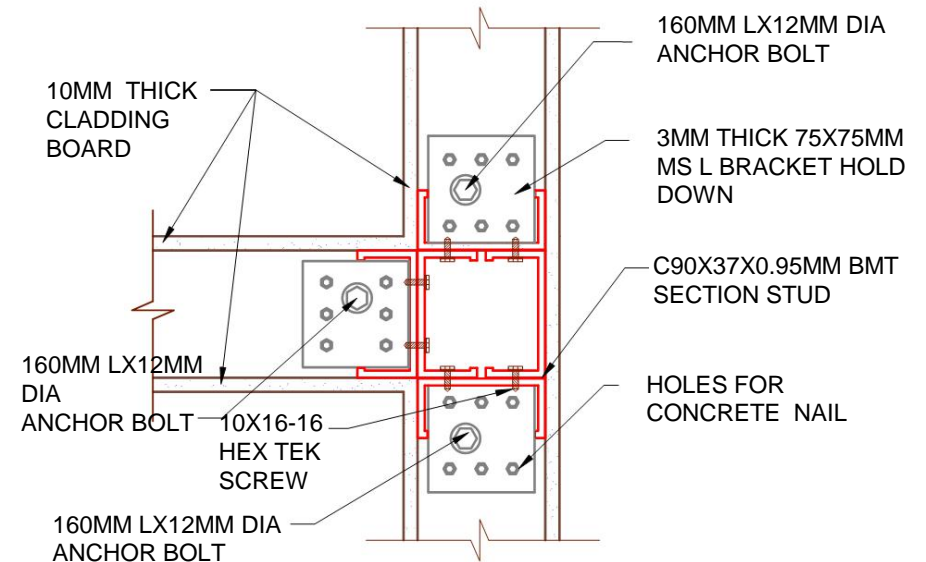

**PLAN VIEW AT INTERSECTION**



MINISTRY OF URBAN DEVELOPMENT  
DEPARTMENT OF URBAN DEVELOPMENT AND BUILDING CONSTRUCTION

HOUSING TYPE: MODEL L.G.S.-9.1

DRAWING TITLE: DETAILS

SCALE: NONE

DATE:

L.G.S 9.1

7/9

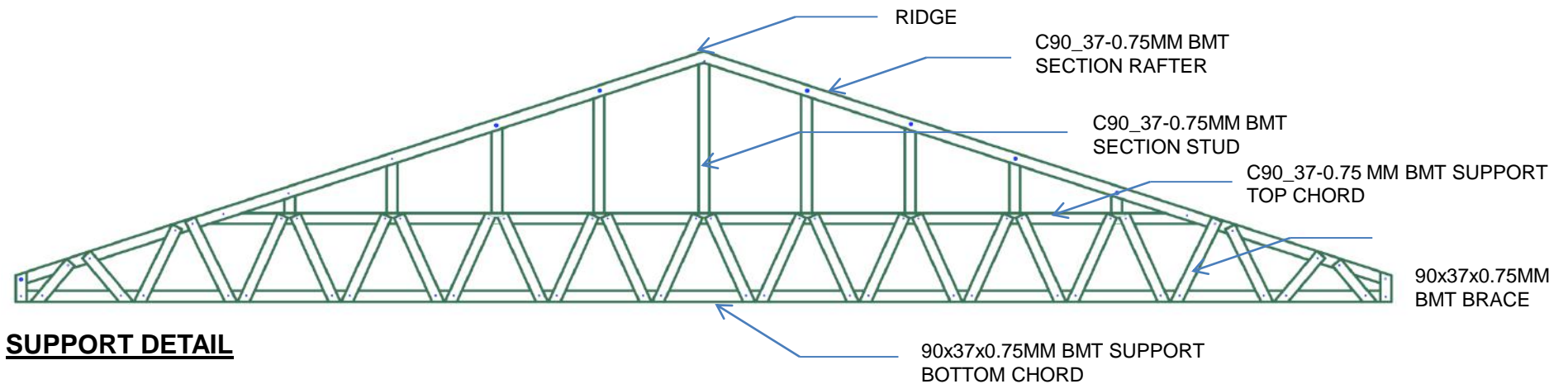
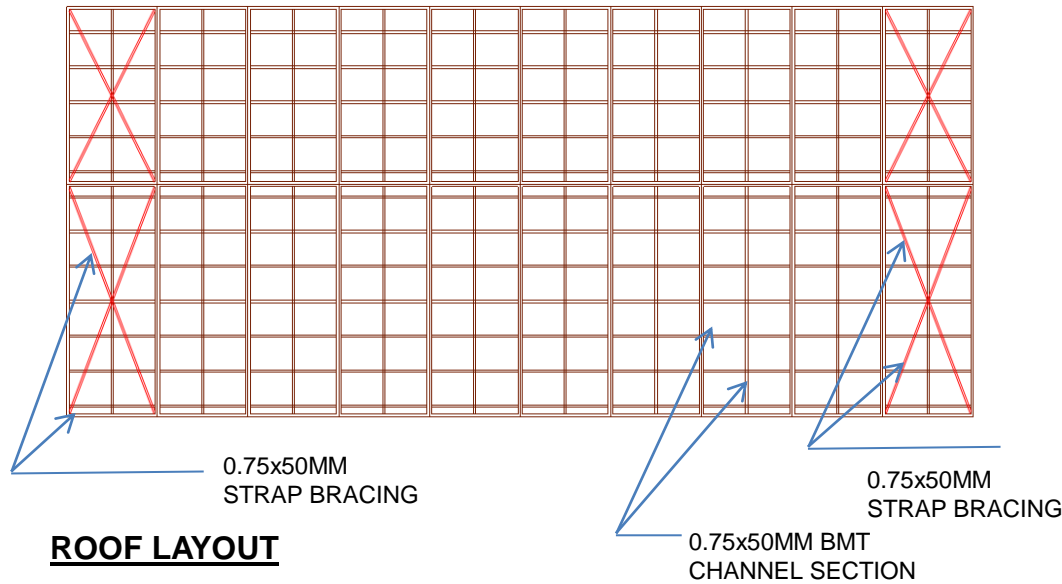

**TECHNICAL REQUIREMENTS**

<b>Structure System</b>	Structural system consisting of thin steel sections clad with materials like light gauge steel panel, Cellular light weight concrete, Cement fiber board, gypsum board, calcium silicate board etc.
<b>Foundation</b>	Strip footing of Random rubble masonry in cement sand mortar with width 900 mm and depth 850 mm.
<b>Plinth Band</b>	R.C.C (1:1.5:3) plinth band of size 230x 230 mm. Main reinforcement shall be 4 nos. of 12mm dia. Bars with 8mm Ø rings at 150mm C/C
<b>Wall System</b>	Wall frames shall be of cold formed steel channel sections of minimum thickness 0.75mm. All the vertical studs and horizontal nog of the wall frames shall be at the spacing mentioned in the drawings.
<b>Bracing:</b>	K Bracing and X Bracing made up of cold formed steel channel sections of minimum thickness 0.75mm as mentioned in drawing
<b>Roof System:</b>	Truss shall be of Cold formed steel channel section of minimum thickness 0.55mm and depth of web 90 mm covered with light roofing materials.





LEVEL	MATERIALS								
	Brick	Cement	Sand	Aggregate	Reinforcing Bar	CGI Sheet	GI Sheet	MS angles & Plates	Wall Board
	No.	Bags	Cu.m.	Cu.m.	Kg.	Bundle	Sq.m.	Cu.m.	Sq.m.
Up to Plinth Level	2,973.0	87.5	6.4	9.5	594.5			-	2.5
Super Structure	-	2.5	0.3	-	-			4,184.8	244.3
Roofing	-	-	-	-	-	5.4	14.8	2,629.8	
<b>TOTAL</b>	<b>2,973.0</b>	<b>2.5</b>	<b>6.7</b>	<b>9.5</b>	<b>594.5</b>	<b>5.4</b>	<b>14.8</b>	<b>6,814.6</b>	<b>246.8</b>





**GROUND FLOOR PLAN**  
FLOOR AREA: 36.19 SQ. M.

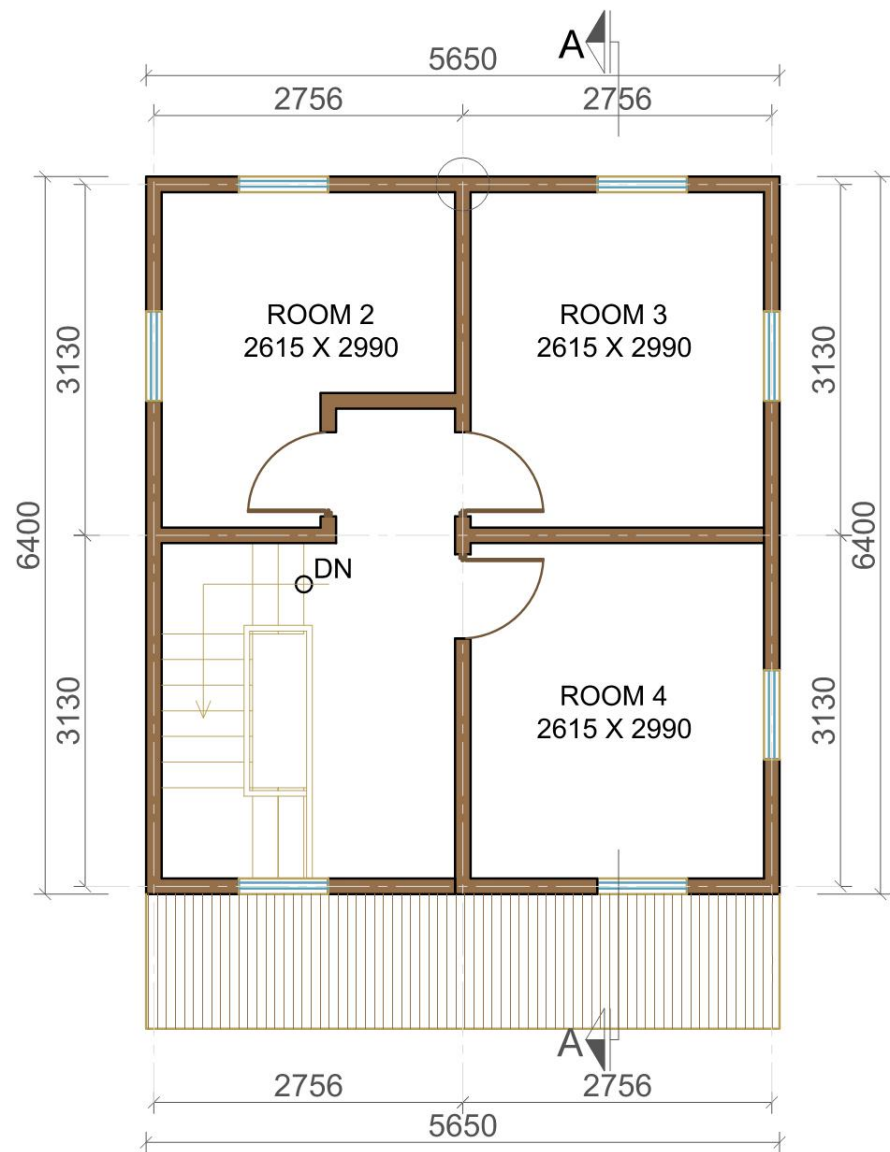

**FIRST FLOOR PLAN**  
FLOOR AREA: 36.19 SQ. M.



**MINISTRY OF URBAN DEVELOPMENT  
DEPARTMENT OF URBAN DEVELOPMENT AND  
BUILDING CONSTRUCTION**

**HOUSING TYPE: MODEL L.G.S.-9.2**

**DRAWING TITLE: FLOOR PLANS**

**SCALE: NONE**

**DATE:**

**L.G.S.-9.2**

**2/7**



**FRONT ELEVATION**

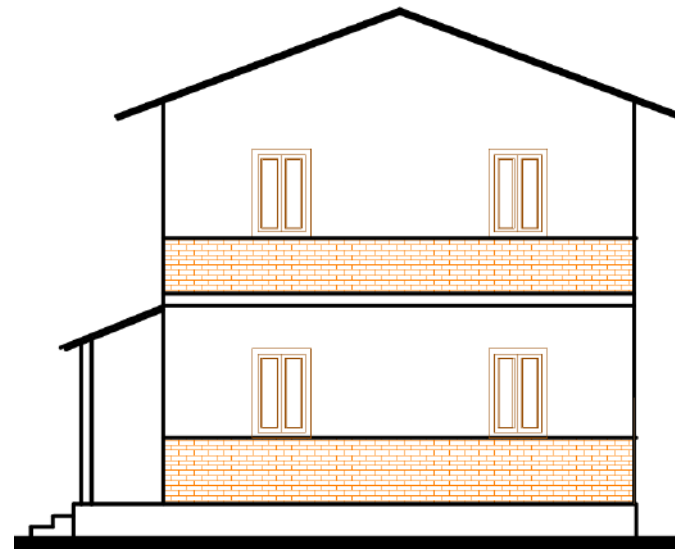

**SIDE ELEVATION**

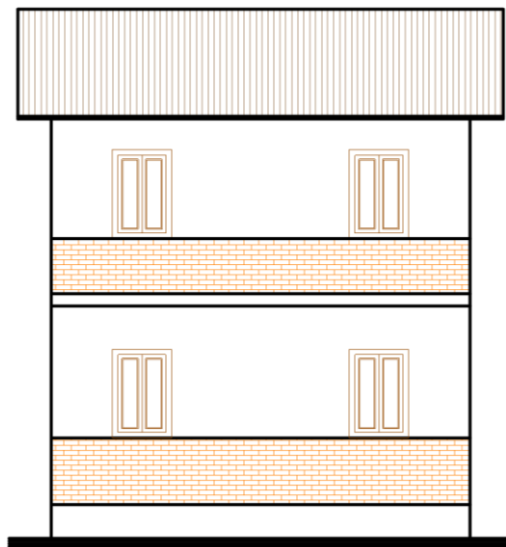

**BACK ELEVATION**

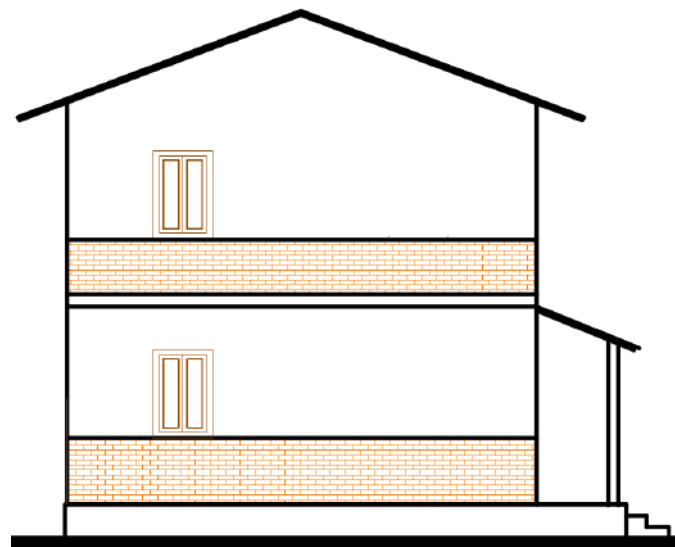

**SIDE ELEVATION**



MINISTRY OF URBAN DEVELOPMENT  
DEPARTMENT OF URBAN DEVELOPMENT AND  
BUILDING CONSTRUCTION

HOUSING TYPE: MODEL L.G.S.-9.2

DRAWING TITLE: ELEVATIONS

SCALE: NONE

DATE:

L.G.S.-9.2

3/7



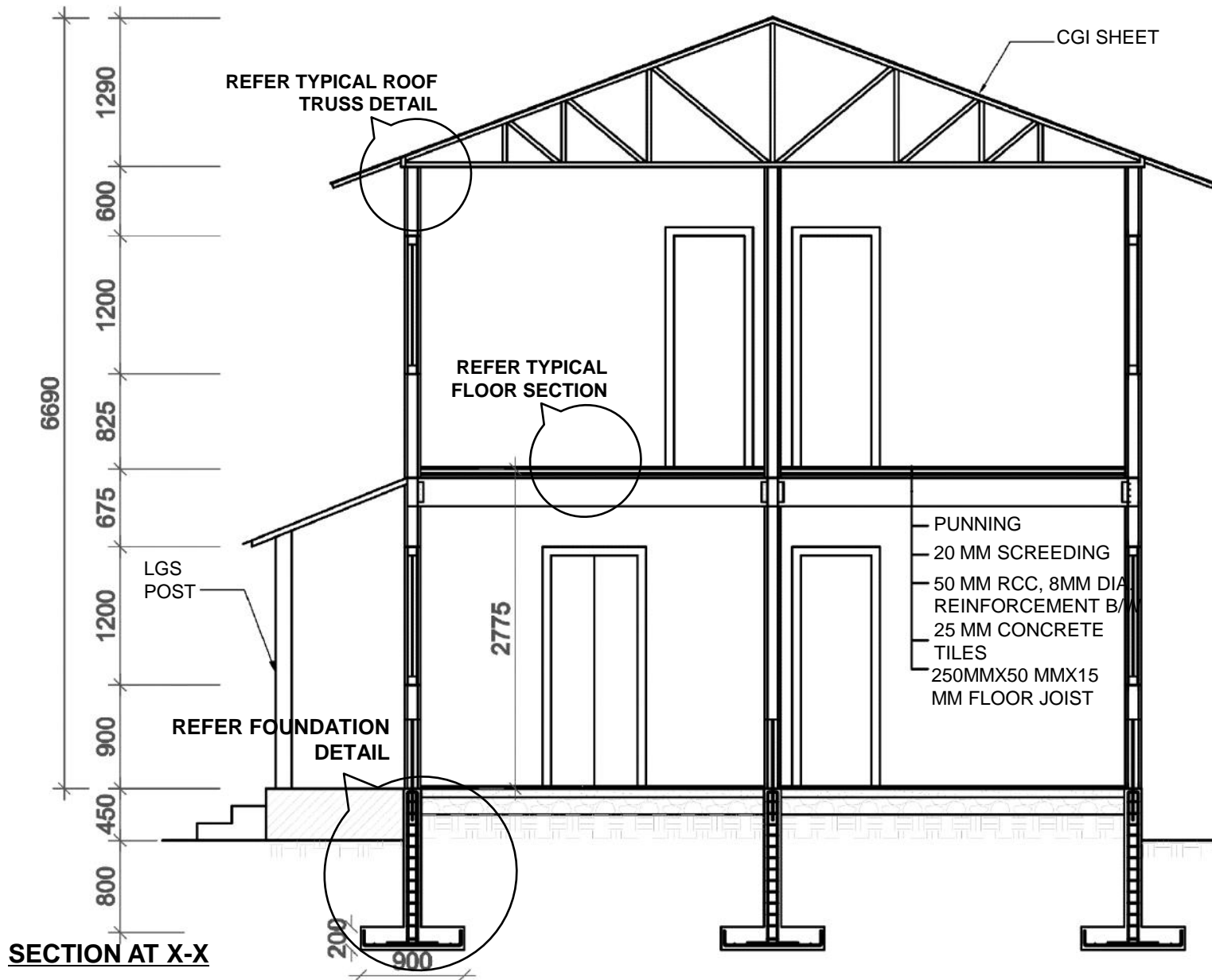

 <p>MINISTRY OF URBAN DEVELOPMENT DEPARTMENT OF URBAN DEVELOPMENT AND BUILDING CONSTRUCTION</p>	HOUSING TYPE: MODEL L.G.S.-9.2	SCALE: NONE	L.G.S.-9.2
	DRAWING TITLE: SECTION	DATE:	4/7

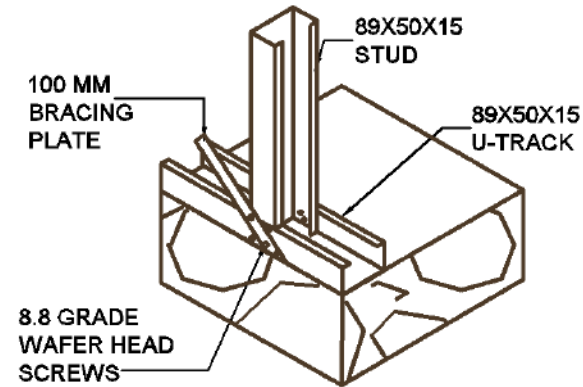
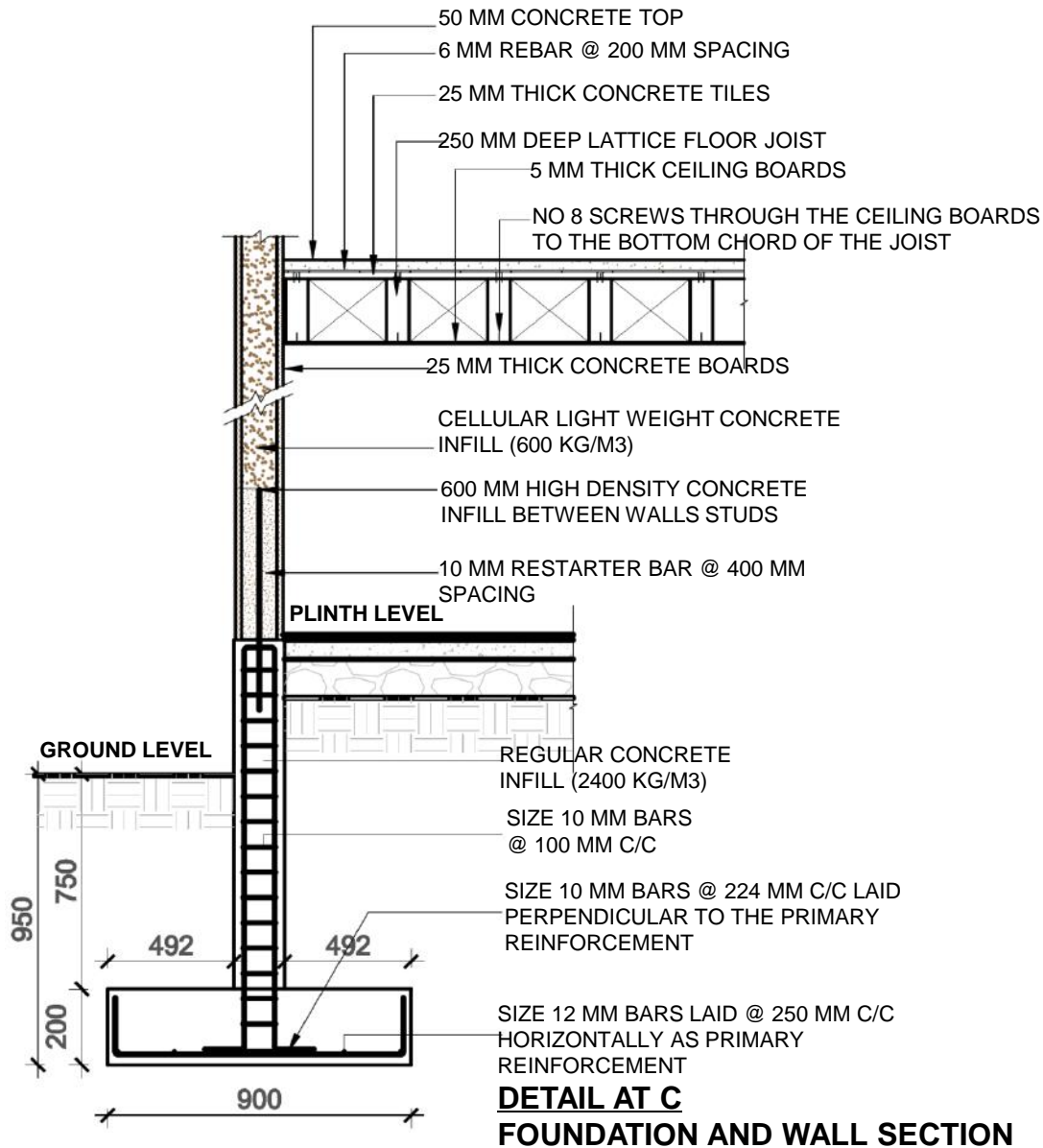

**U-TRACK OVER CONCRETE SLAB**

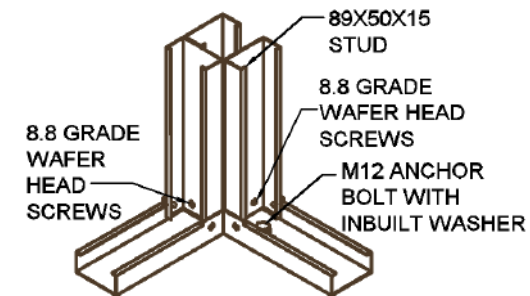

**FRAME CONNECTION TO WALL L BRACKET HOLD DOWN**



MINISTRY OF URBAN DEVELOPMENT  
 DEPARTMENT OF URBAN DEVELOPMENT AND  
 BUILDING CONSTRUCTION

HOUSING TYPE: MODEL L.G.S.-9.2

DRAWING TITLE: DETAILS

SCALE: NONE

DATE:

L.G.S.-9.2

5/7

# MODEL L.G.S.-9.2, LIGHT GAUGE SHEET STRUCTURE

TWO STOREY

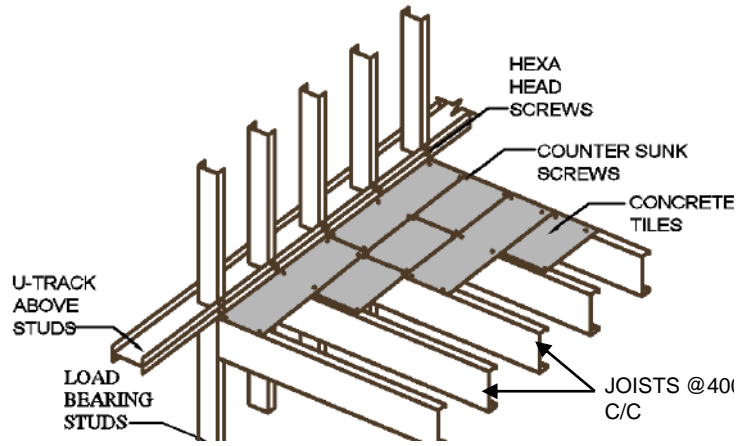

**TYPICAL FLOOR SECTIONS**

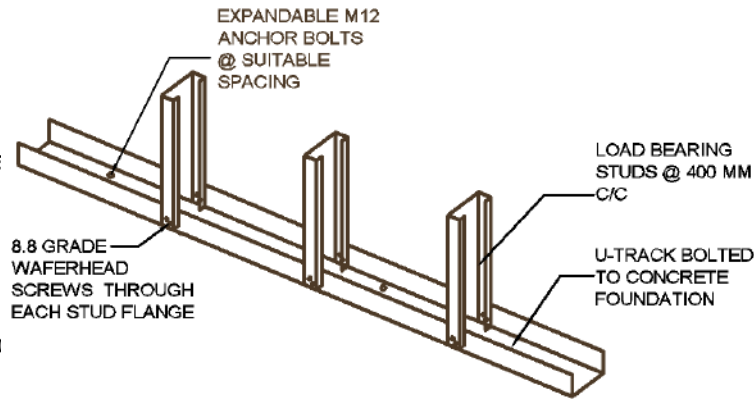

**ISOMETRIC VIEW OF STUDS ARRANGEMENT**

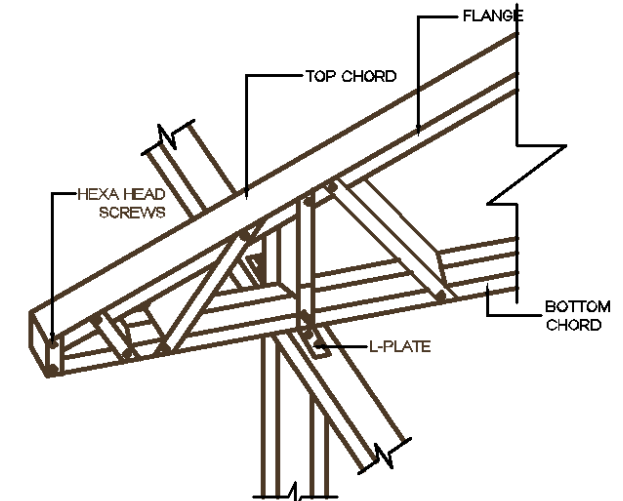

**TYPICAL ROOF TRUSS TO STUD CONNECTIONS**

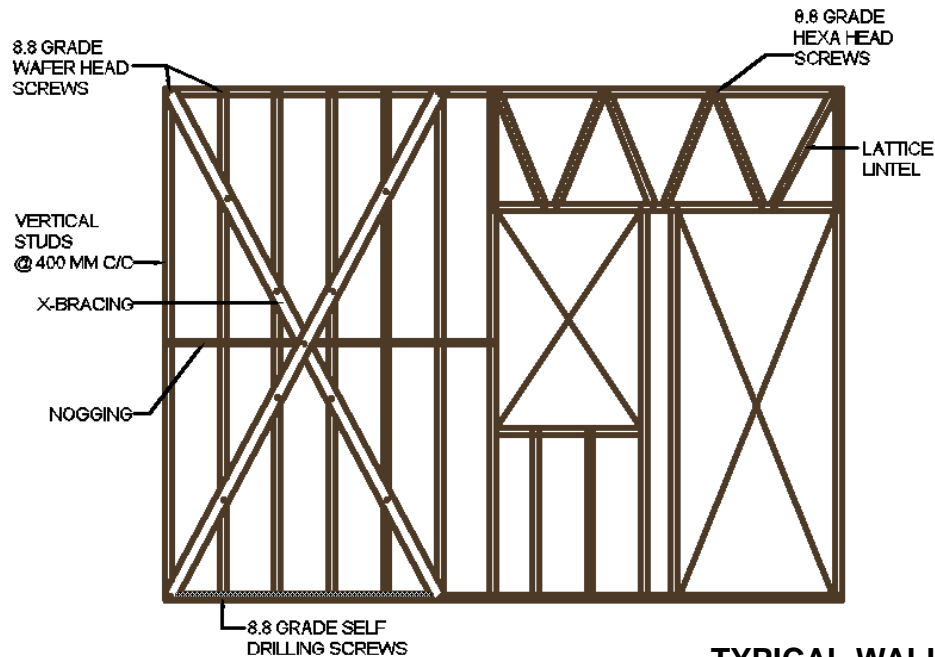

**TYPICAL WALL SECTION**

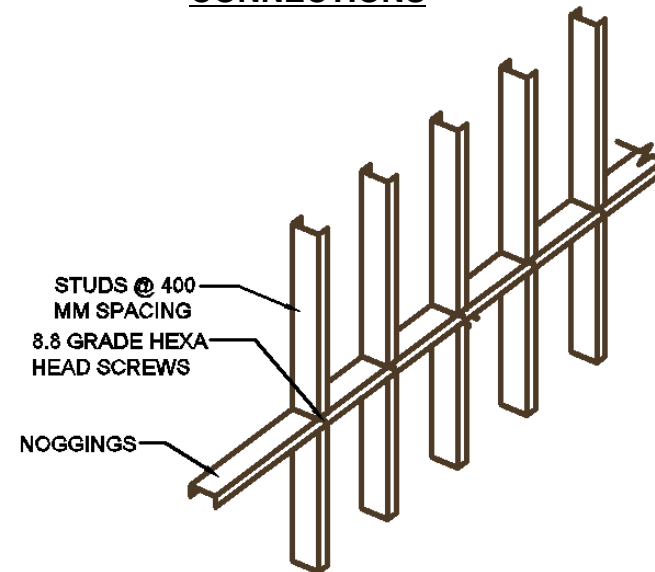

**TYPICAL NOGGING SECTION**



MINISTRY OF URBAN DEVELOPMENT  
DEPARTMENT OF URBAN DEVELOPMENT AND  
BUILDING CONSTRUCTION

HOUSING TYPE: MODEL L.G.S.-9.2

DRAWING TITLE: DETAILS

SCALE: NONE

DATE:

L.G.S.-9.2

6/7

**TECHNICAL REQUIREMENTS**

<b>Structure System</b>	Structural system consisting of thin steel sections clad with Cellular light weight concrete tiles. Minimum tensile strength and yield strength of Light gauge steel to be 350 Mpa and 450 Mpa respectively.
<b>Foundation</b>	Reinforced Concrete strip footing of size as specified in detail drawing on foundation of width 900mm and depth 950mm.LGS tracks shall be bolted to the foundation using M12 expandable bolts at an interval of 1.2m-1.8m.
<b>Wall System</b>	Wall frames shall be of cold formed steel channel sections. All the vertical studs and horizontal joists of the wall frames shall be at the spacing mentioned in the drawings.
<b>Flooring System</b>	The flooring System shall be of 50 mm RCC on 25 mm concrete tiles on 250 x 50 x 15 mm floor joists
<b>Roof System</b>	Light roof steel truss covered with CGI sheets. All members of the truss or joints shall be properly connected as shown in detail drawings.



# STEEL STRUCTURE

**S.S.-10.1**

S.S 10.1 is a structural system consisting of mild steel columns and beams to make steel moment resisting frame system. Both the gravity and lateral load is resisted by moment resisting frame. The floor system is made of profile metal decking system over which the thin layer of RCC is laid. The roofing system consists of MS Steel tubes truss with CGI Sheet. The infill wall consists of light weight partition wall made of light weight material having density less than 1000Kg/m<sup>3</sup>

The featured design consists of two storey residential building consisting of 6 nos. of room.

### **MATERIAL PROPERTIES AND SPECIFICATION**

Structural Steel Yield Strength: Fe250

CGI Sheet: min 53 gauge

Infill material density  $\geq$  1000kg/m<sup>3</sup>

Mix ratio grade: 1:1.5:3

Tensile Strength of rebar: Fe 500

# **S.S.-10.1**



LEVEL	MATERIALS										
	Brick	Cement	Sand	Aggregate	Reinforcing Bar	MS pipe	Steel sections	CGI Sheet	GI Plain sheet	Aluminium Door	Aluminium Window
	No.	Bags	Cu.m.	Cu.m.	Kg.	Kg.	Kg.	Bundle	Sq.m.	Sq.m.	Sq.m.
Up to Plinth Level	3,384.0	130.0	11.0	13.0	974.0	-	-			-	-
Super Structure	-	111.0	5.0	10.0	582.0	-	3,930.1			10.3	22.6
Roofing	-	-	-	-	-	845.4	-	6.3	11.1	-	-
<b>TOTAL</b>	<b>3,384.0</b>	<b>241.0</b>	<b>16.0</b>	<b>23.0</b>	<b>1,556.0</b>	<b>845.4</b>	<b>3,930.1</b>	<b>6.3</b>	<b>11.1</b>	<b>10.3</b>	<b>22.6</b>



MINISTRY OF URBAN DEVELOPMENT  
DEPARTMENT OF URBAN DEVELOPMENT AND  
BUILDING CONSTRUCTION

HOUSING TYPE: MODEL S.S-10.1

SCALE: NONE

S.S.-10.1

DRAWING TITLE: ESTIMATION AND 3D-VIEW

DATE:

1/11

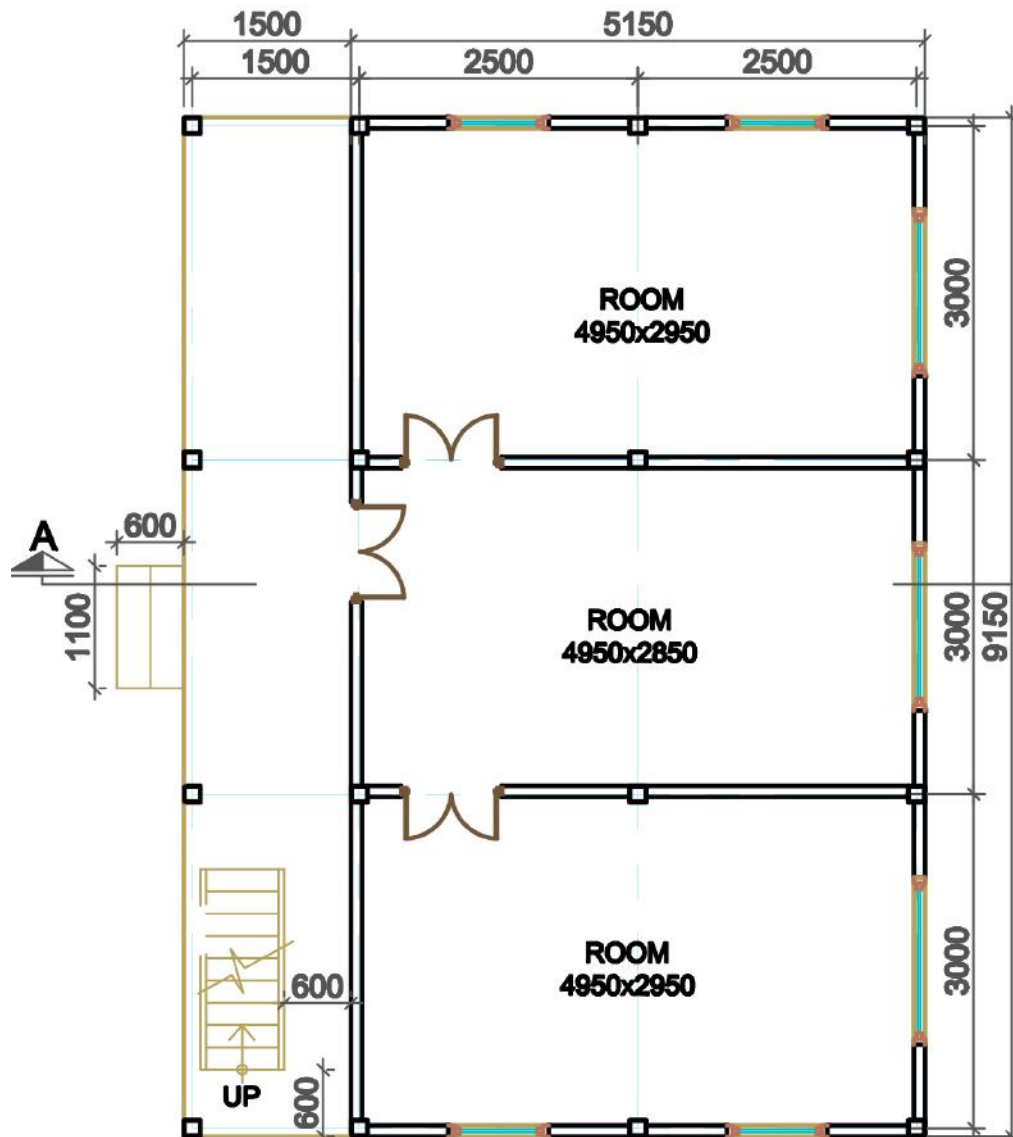

**GROUND FLOOR PLAN**

AREA: 60.85 SQ.M

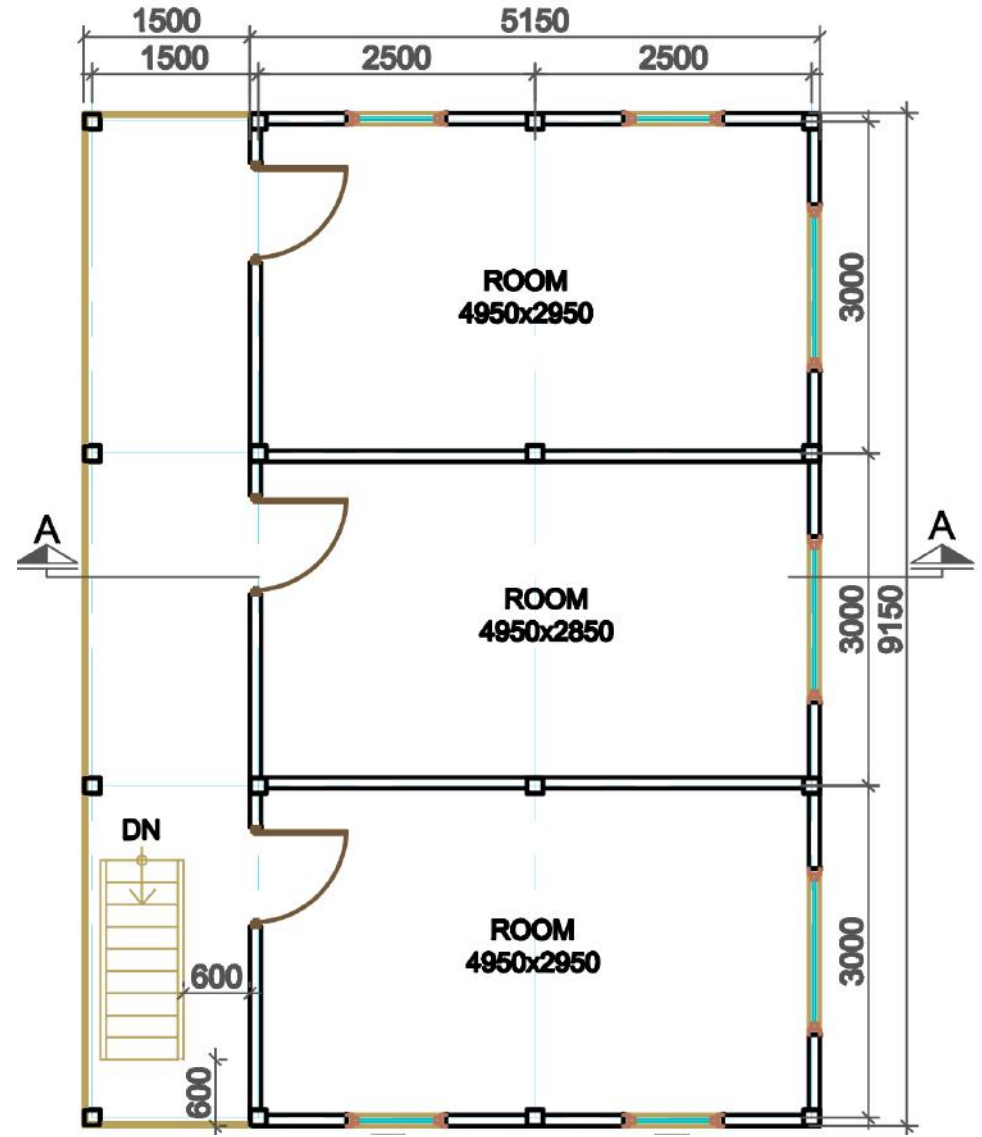

**FIRST FLOOR PLAN**

AREA: 60.85 SQ.M



MINISTRY OF URBAN DEVELOPMENT  
DEPARTMENT OF URBAN DEVELOPMENT AND  
BUILDING CONSTRUCTION

HOUSING TYPE: MODEL S.S-10.1

DRAWING TITLE: FLOOR PLANS

SCALE: NONE

DATE:

S.S.-10.1

2/11



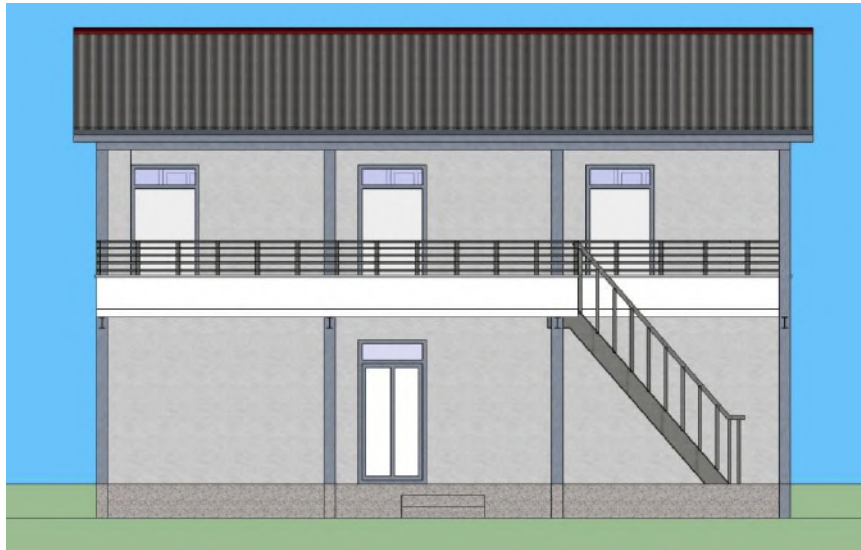

**FRONT ELEVATION**



**RIGHT SIDE ELEVATION**



**BACK ELEVATION**



**LEFT SIDE ELEVATION**



**MINISTRY OF URBAN DEVELOPMENT  
DEPARTMENT OF URBAN DEVELOPMENT AND  
BUILDING CONSTRUCTION**

**HOUSING TYPE: MODEL S.S-10.1**

**DRAWING TITLE: ELEVATIONS**

**SCALE: NONE**

**DATE:**

**S.S.-10.1**

**3/11**

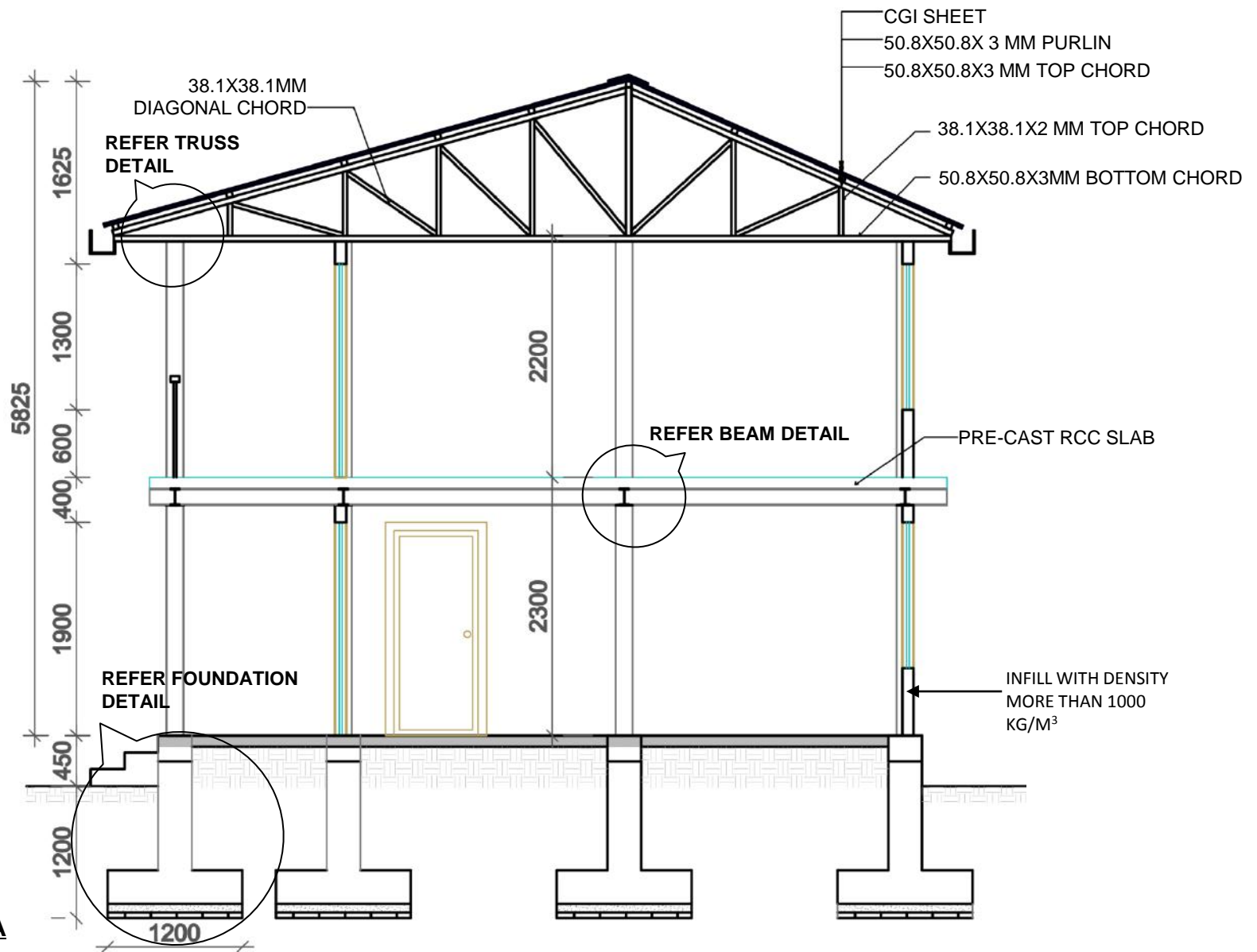

**SECTION AT A-A**



MINISTRY OF URBAN DEVELOPMENT  
DEPARTMENT OF URBAN DEVELOPMENT AND  
BUILDING CONSTRUCTION

HOUSING TYPE: MODEL S.S-10.1

DRAWING TITLE: SECTION

SCALE: NONE

DATE:

S.S.-10.1

4/11

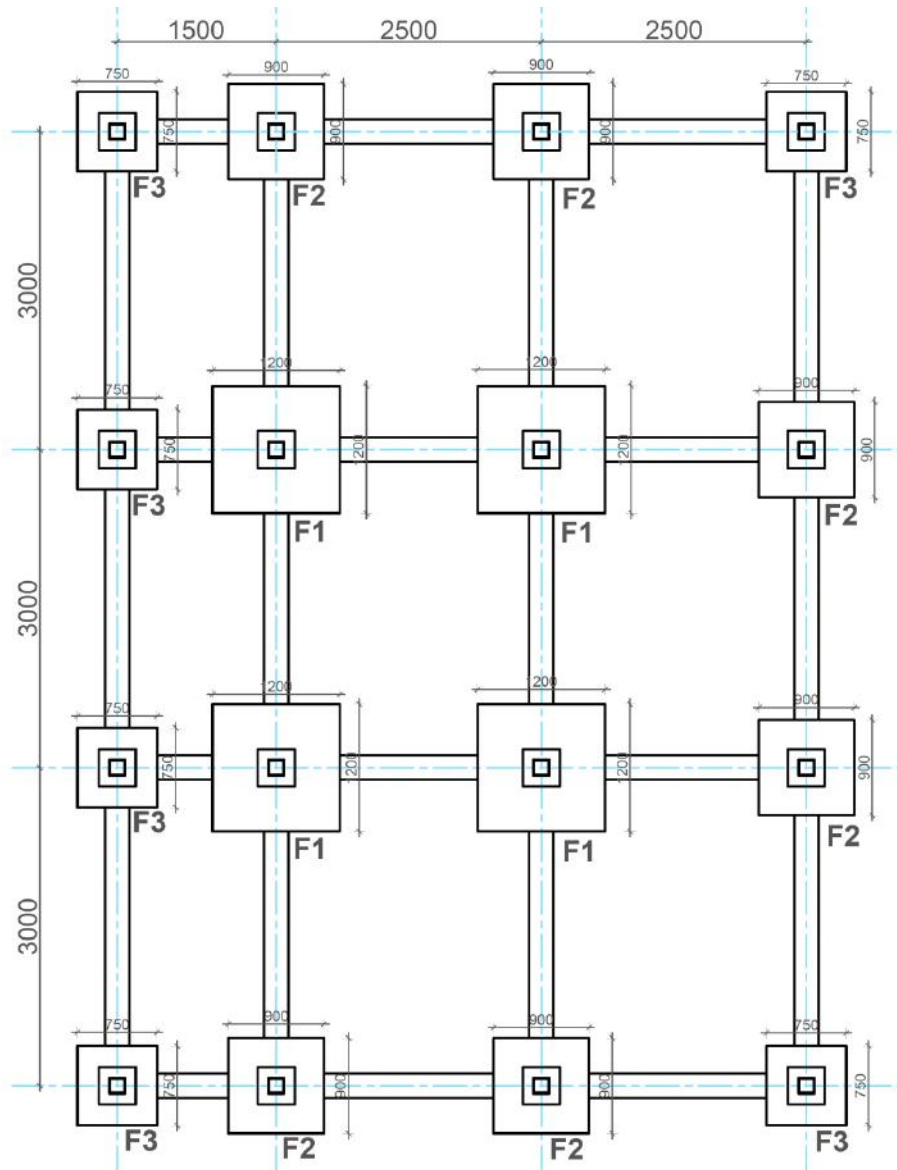

**FOUNDATION TRENCH PLAN**

**FOUNDATION DETAIL**

Serial No.	Foundation Type	Foundation Size (LxB)	Footing sizes and reinforcement details	
			Depth (D)	Rebar
1	F1	1200x1200	300	T10@150mm c\c-bothway
2	F2	900x900	300	T10@150mm c\c-bothway
3	F3	750x750	300	T10@150mm c\c-bothway



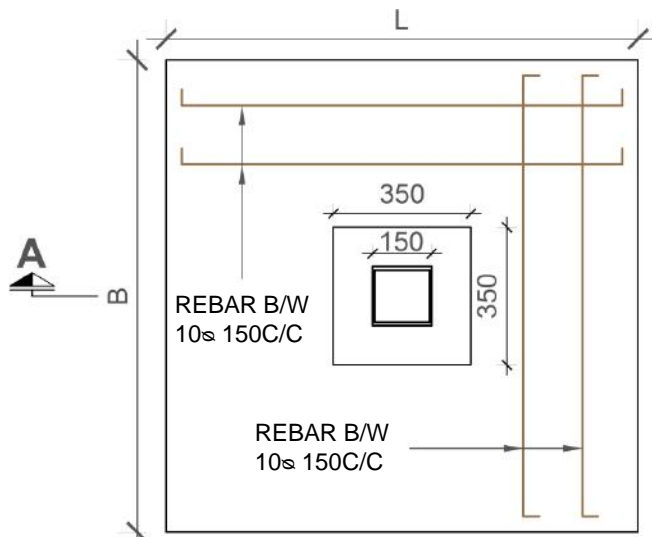

**FOUNDATION PLAN**

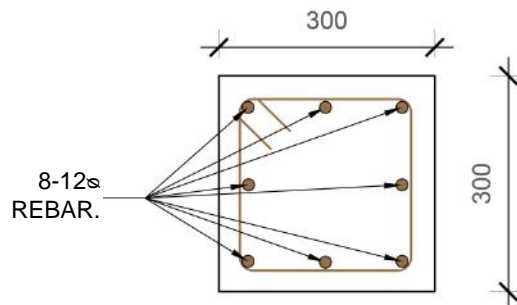

**PEDESTAL COLUMN**

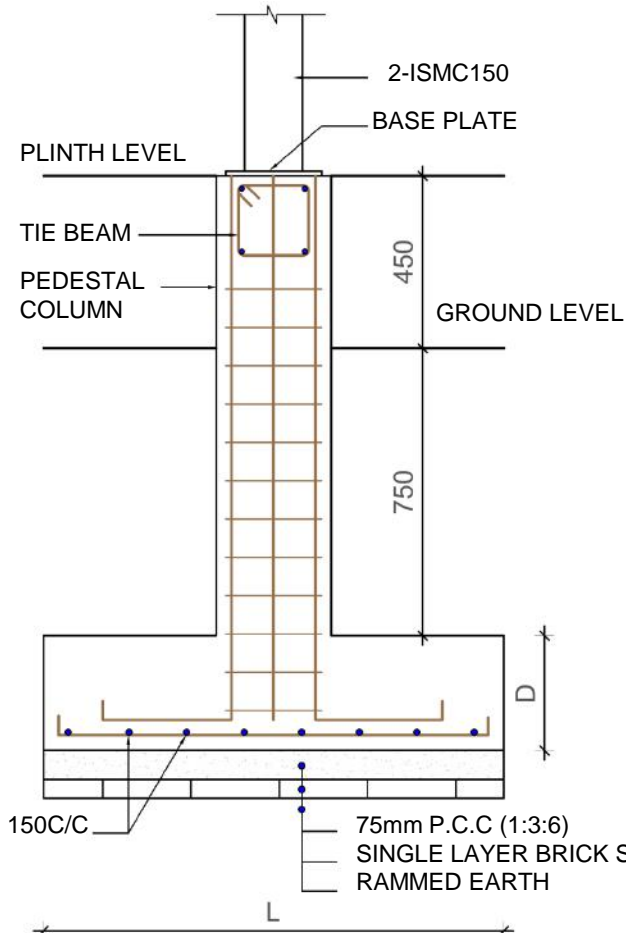

**FOUNDATION SECTION AT A-A**

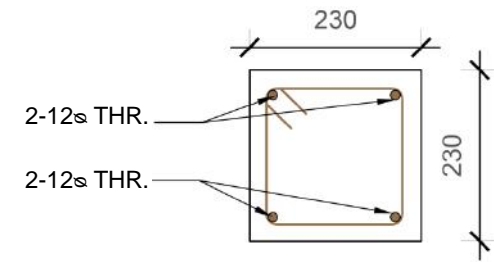

**TIE BEAM**

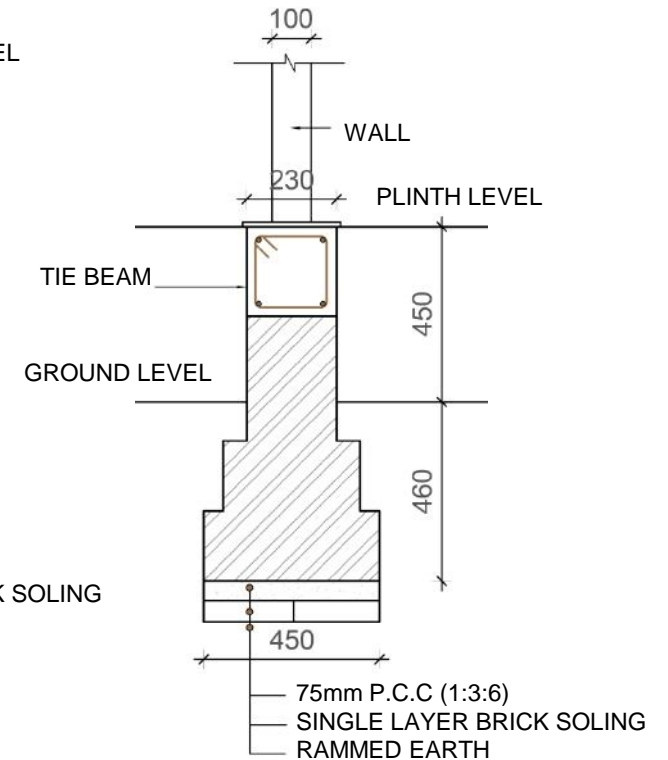

**TOE WALL**



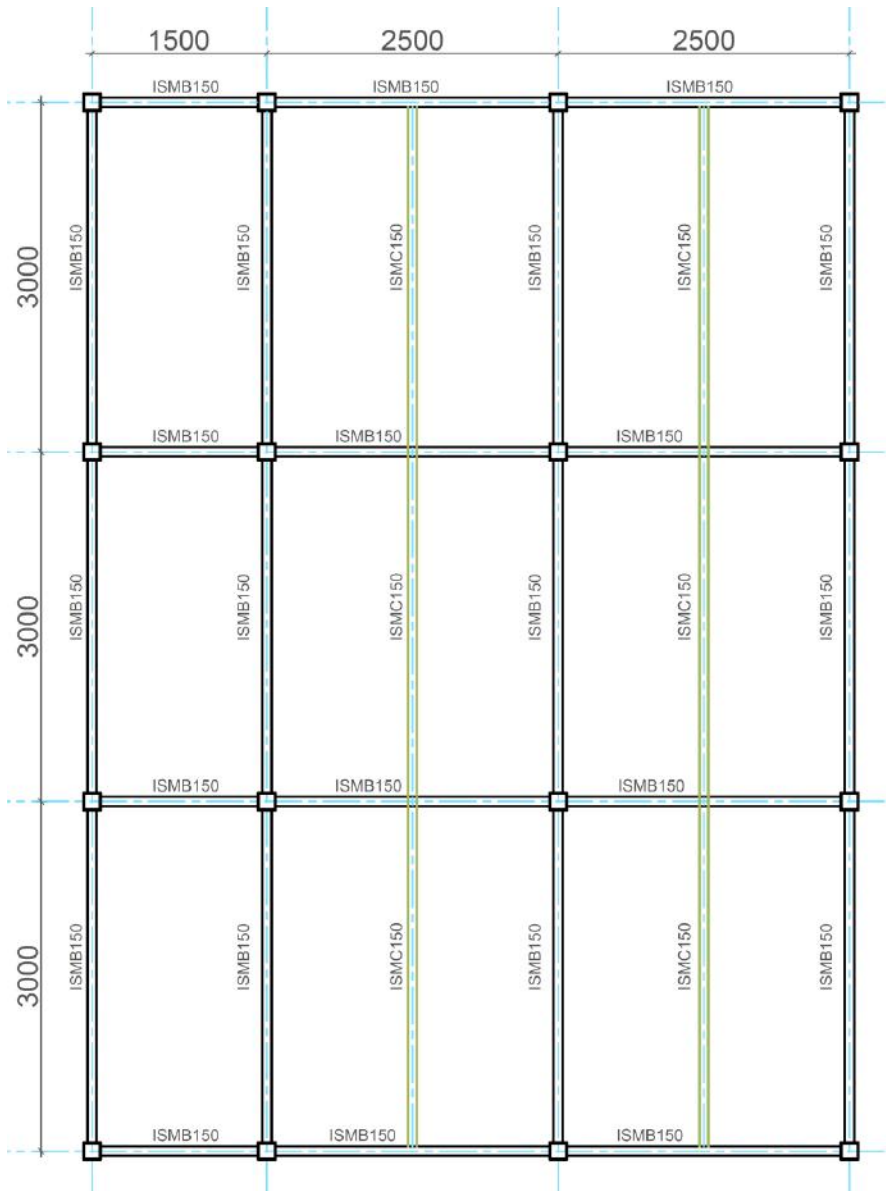

**BEAM-COLUMN PLAN**

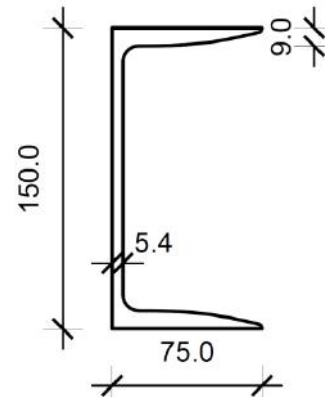

**ISMC150  
(SECONDARY BEAM)**

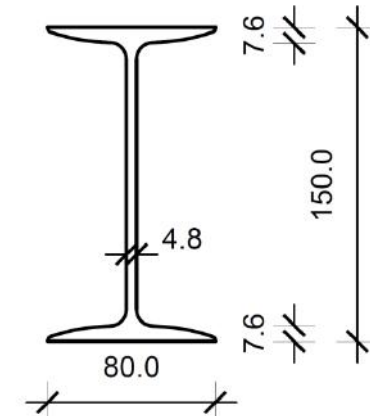

**ISMB150  
(PRIMARY BEAM)**

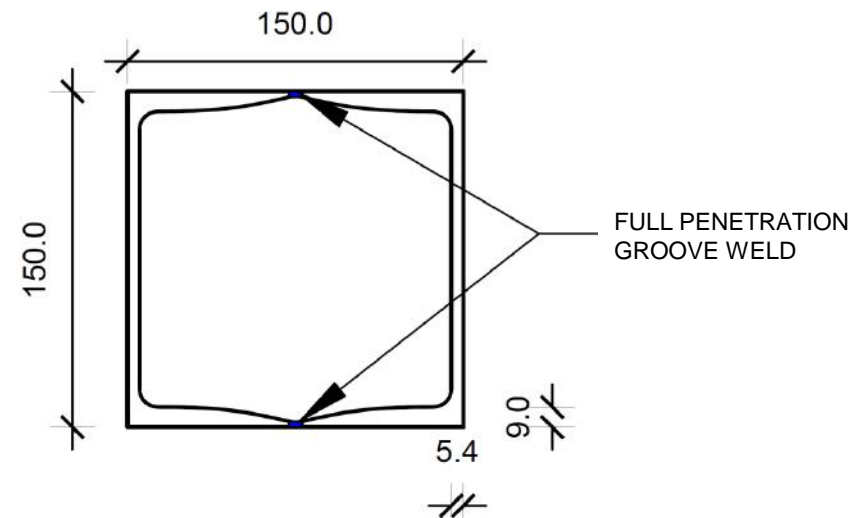

**2-ISMC150(COLUMN)**



MINISTRY OF URBAN DEVELOPMENT  
DEPARTMENT OF URBAN DEVELOPMENT AND  
BUILDING CONSTRUCTION

HOUSING TYPE: MODEL S.S-10.1

DRAWING TITLE: STRUCTURE DETAILS

SCALE: NONE

DATE:

S.S.-10.1

7/11

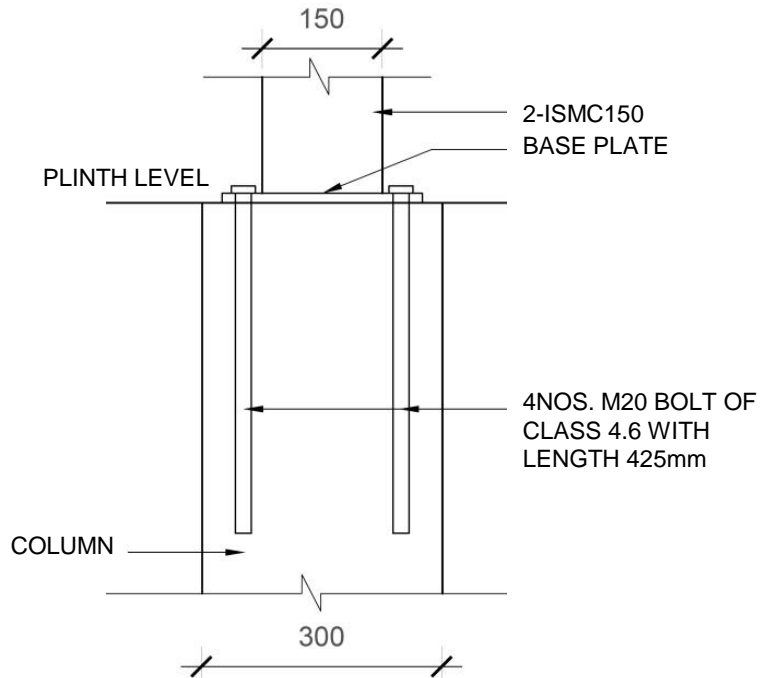

**BASE PLATE CONNECTION SECTION**

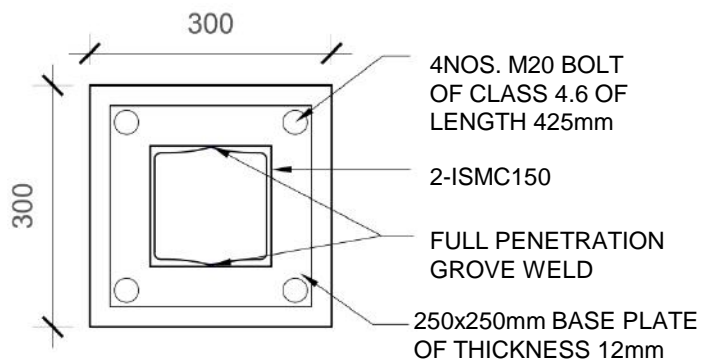

**BASE PLATE CONNECTION PLAN**

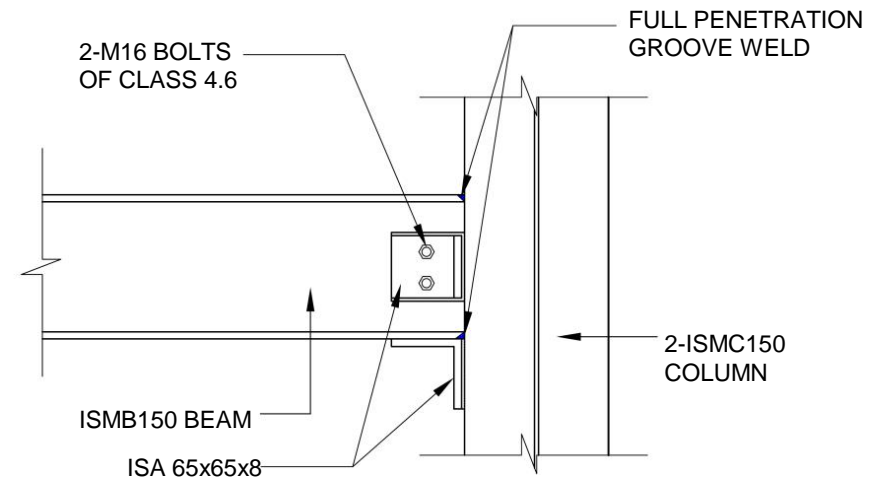

**BEAM AND COLUMN CONNECTION**

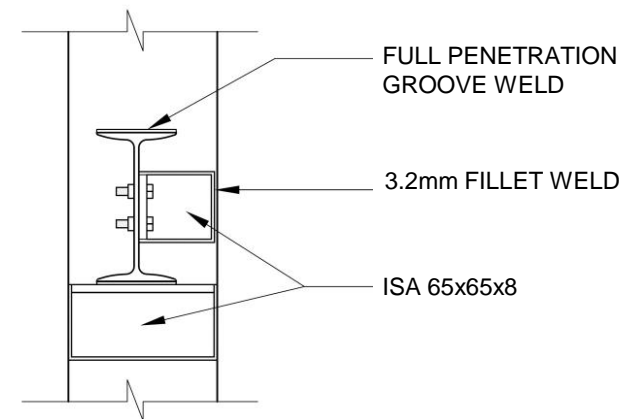

**BEAM AND COLUMN CONNECTION**



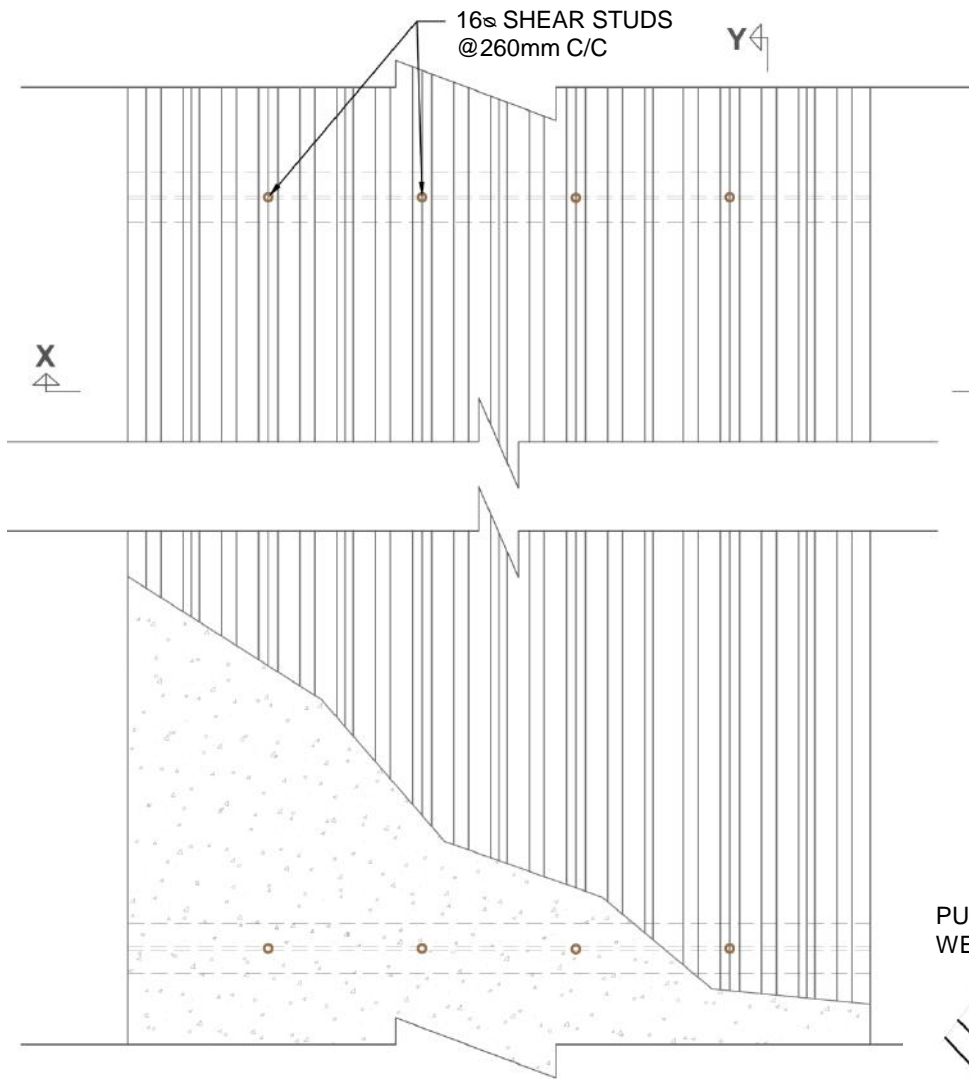

**COMPOSITE FLOOR PLAN**

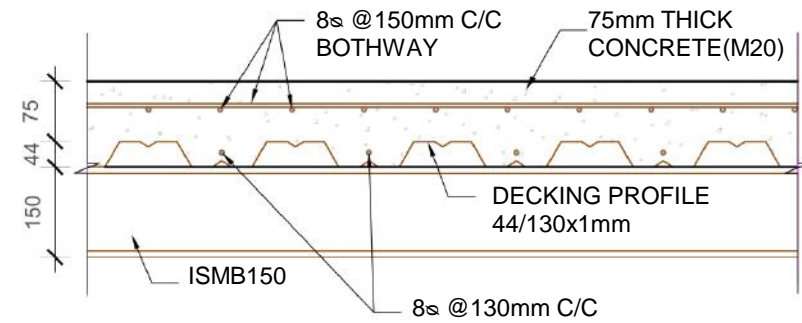

**SECTION AT X-X**

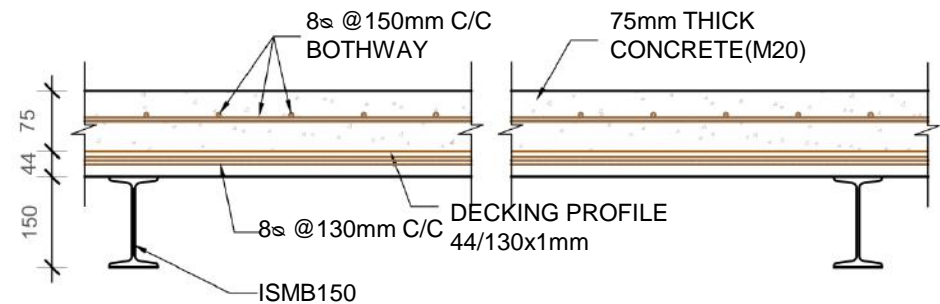

**SECTION AT Y-Y**

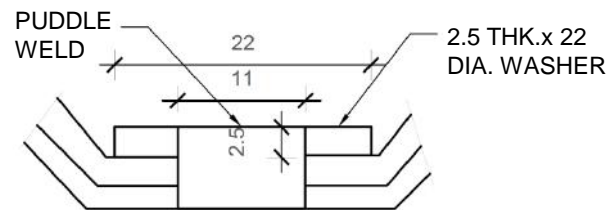

**LAP DETAIL**

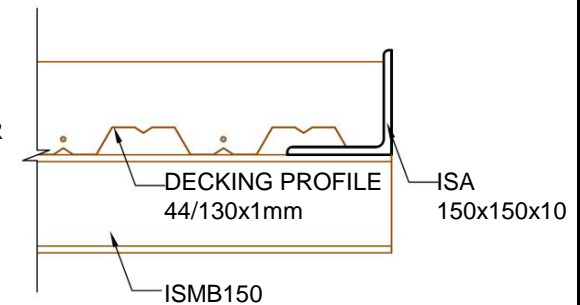

**END ANGLE DETAIL**



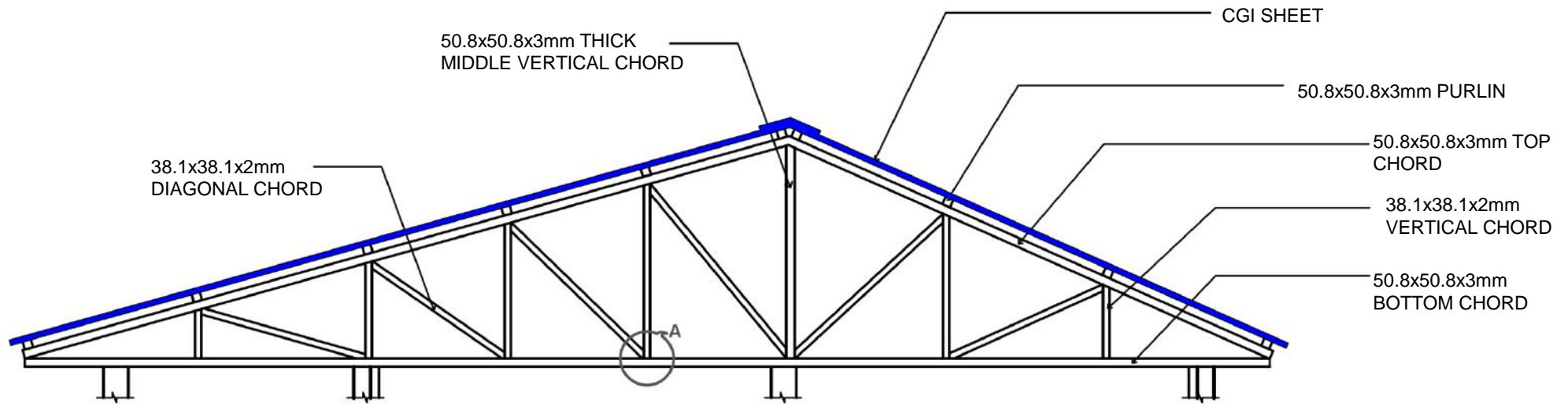

**TRUSS DETAIL**

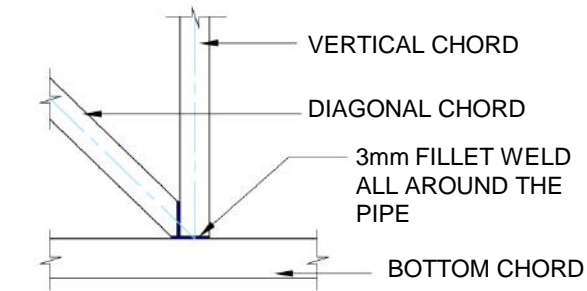

**DETAIL AT A**

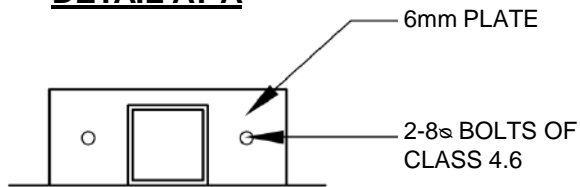

**CLEFT DETAIL**

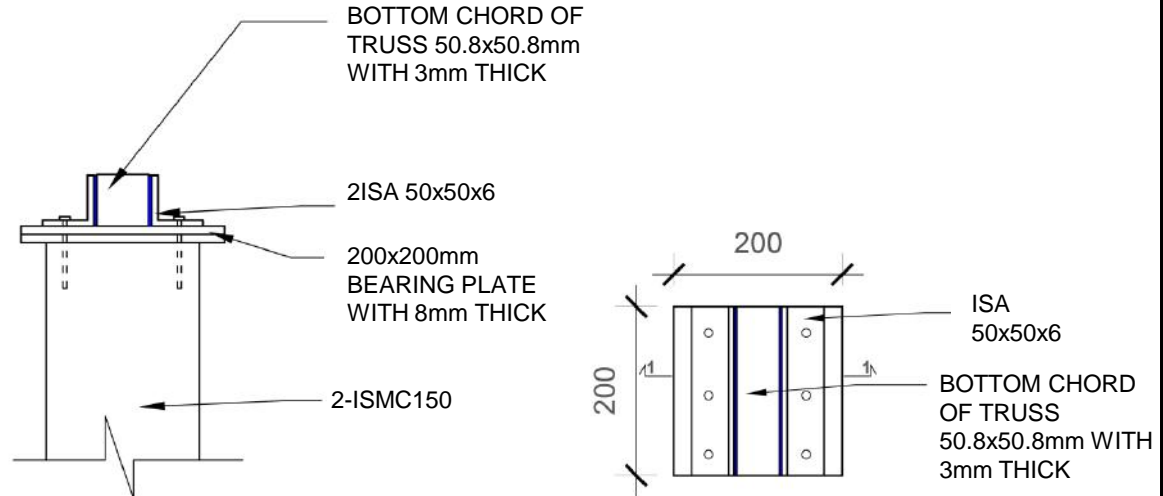

**SECTION AT 1-1**

**PLAN**

**TRUSS COLUMN CONNECTION DETAIL**



MINISTRY OF URBAN DEVELOPMENT  
DEPARTMENT OF URBAN DEVELOPMENT AND  
BUILDING CONSTRUCTION

HOUSING TYPE: MODEL S.S-10.1

DRAWING TITLE: STRUCTURE DETAILS

SCALE: NONE

DATE:

S.S.-10.1

10/11



**TECHNICAL REQUIREMENTS**

<b>Structure System</b>	Moment resisting steel frame system.
<b>Foundation</b>	Isolated footing shown in detail drawing. Depth of Pedestal Column of 1.05 meters from ground level and width shown as per design in table.
<b>Tie beam:</b>	R.C.C (1:1.5:3) tie beam of size 230x 230 mm. Main reinforcement shall be 4 nos. of 12mm dia. Bars with 8mm Ø rings at 150mm C/C
<b>Wall System</b>	Infill walls with density more than 1000 kg/m <sup>3</sup> on moment resisting steel frame.
<b>Column:</b>	Two ISMC150 column with full penetration groove weld in factory is used in structure.
<b>Beam:</b>	ISMB 150 shall be used as primary beam. ISMC 150 shall be used for Secondary Beam.
<b>Flooring System:</b>	The flooring System shall be made of profile metal decking system. Thin layer of RC concrete shall be laid as shown in detail drawing.
<b>Roof System:</b>	Light roof steel truss covered with CGI sheets. All members of the truss or joints shall be properly connected as shown in detail drawings.



# TIMBER STRUCTURE

T.S.-11.1

T.S 11.1 is a structural system consisting of timber studs (vertical members) and horizontal member load bearing system. The gravity load is resisted by the studs and lateral load is resisted by the timber bracing located at strategic positions. The floor system consists of wooden joist over which the wooden planks are laid. The roofing system consists of wooden truss system with CGI sheet. The timber planks are used as light weight partition walls. The featured design consists of two storied resident having 6 number of rooms.

### **PROPERTIES OF TIMBER**

Density: 640 kg/m<sup>3</sup>

Modulus of Elasticity:  $9.4 \times 10^3$  N/mm<sup>2</sup>

Binding & tension along Grains, Extreme Fiber Stress, inside location: 13.7 N/mm<sup>2</sup>

Binding & tension along Grains, Extreme Fiber Stress, outside location: 11.4 N/mm<sup>2</sup>

Shear Stress, Horizontal in Beams all locations: 1 N/mm<sup>2</sup>

Shear Stress, along grains all locations: 1.4 N/mm<sup>2</sup>

Compressive Stress, inside location (parallel to grains): 8.6 N/mm<sup>2</sup>

Compressive Stress, outside location (parallel to grains): 7.7 N/mm<sup>2</sup>

# T.S.-11.1



LEVEL	MATERIALS										
	Brick	Cement	Sand	Aggregate	Reinforcing Bar	MS Angle & Plates	Wood	CGI Sheet	GI Plain sheet	Aluminium Door	Aluminium Window
	No.	Bags	Cu.m.	Cu.m.	Kg.	Kg.	Cu.m.	Bundle	Sq.m.	Sq.m.	Sq.m.
Up to Plinth Level	3,652.7	113	16.7	8.7	630.0	-	-			-	-
Super Structure	-	18	1.2	2.2	-	526.3	16.3			10.3	22.6
Roofing	-	-	-	-	-	-	0.2	6.7	11.4	-	-
<b>TOTAL</b>	<b>3,652.7</b>	<b>131</b>	<b>17.9</b>	<b>10.9</b>	<b>630.0</b>	<b>526.3</b>	<b>16.5</b>	<b>6.7</b>	<b>11.4</b>	<b>10.3</b>	<b>22.6</b>



MINISTRY OF URBAN DEVELOPMENT  
DEPARTMENT OF URBAN DEVELOPMENT AND  
BUILDING CONSTRUCTION

HOUSING TYPE: MODEL T.S-11.1

SCALE: NONE

T.S.-11.1

DRAWING TITLE: ESTIMATE AND 3D-VIEW

DATE:

1/8

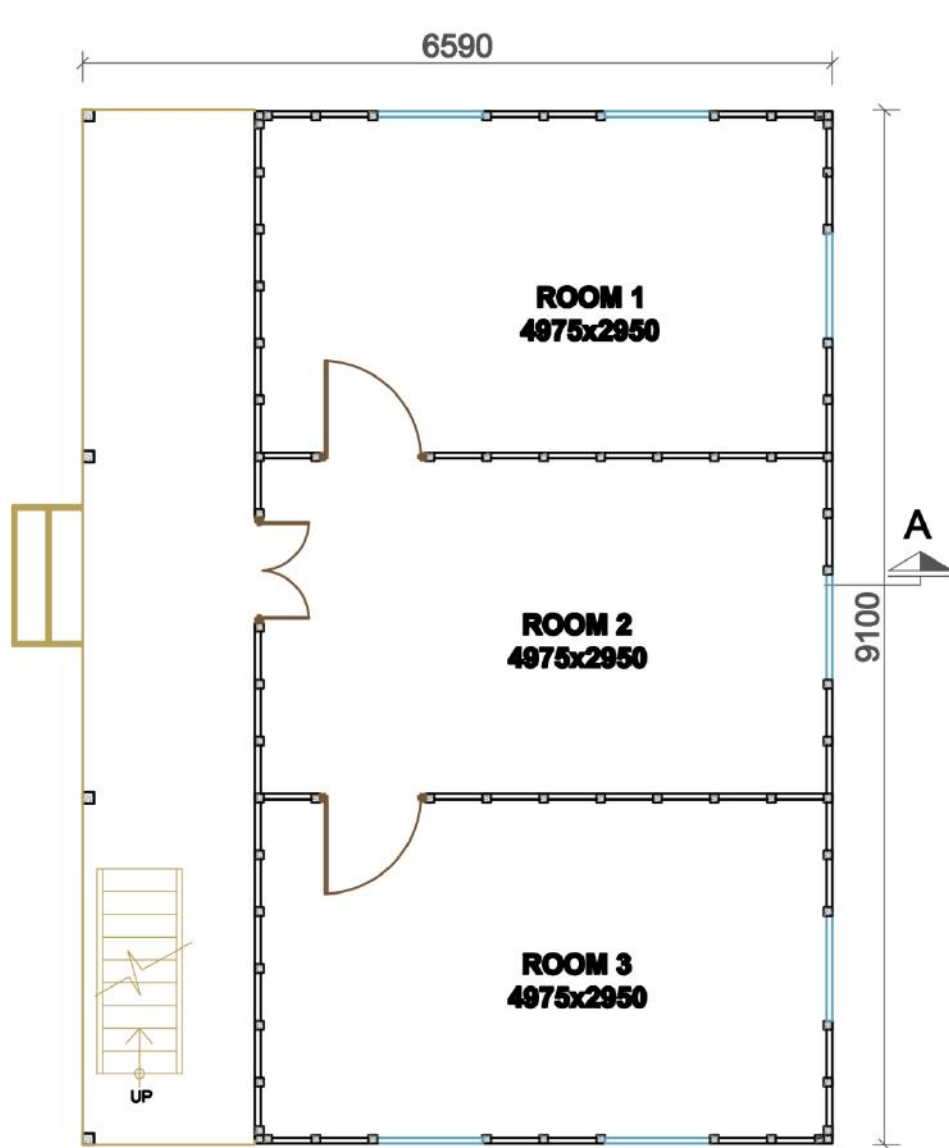

**GROUND FLOOR PLAN**  
AREA: 61.64 SQ.M.

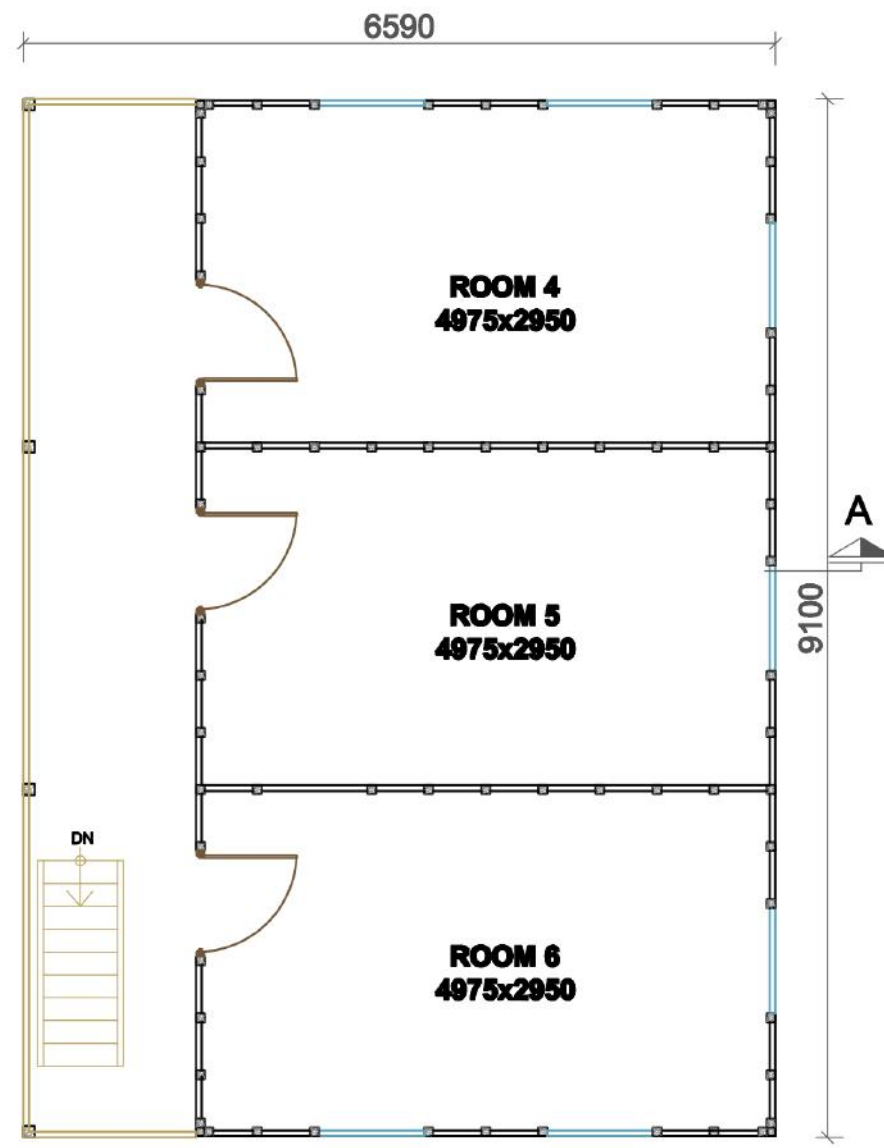

**FIRST FLOOR PLAN**  
AREA: 61.64 SQ.M.



MINISTRY OF URBAN DEVELOPMENT  
DEPARTMENT OF URBAN DEVELOPMENT AND  
BUILDING CONSTRUCTION

HOUSING TYPE: MODEL T.S-11.1

DRAWING TITLE: FLOOR PLANS

SCALE: NONE

DATE:

T.S.-11.1

2/8



**FRONT ELEVATION**



**RIGHT SIDE ELEVATION**



**BACK ELEVATION**

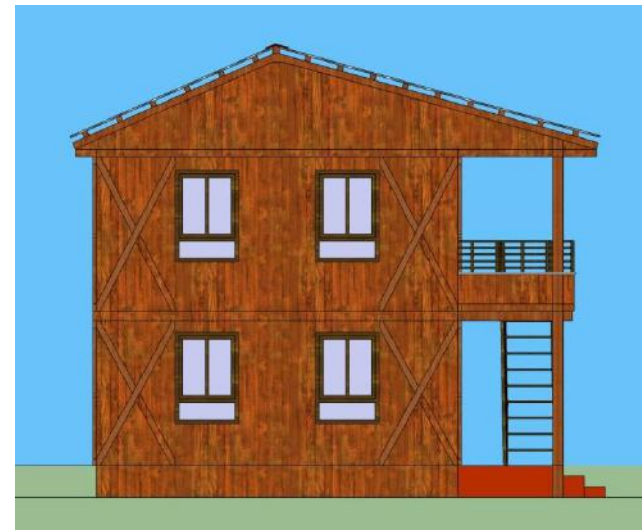

**LEFT SIDE ELEVATION**



MINISTRY OF URBAN DEVELOPMENT  
DEPARTMENT OF URBAN DEVELOPMENT AND  
BUILDING CONSTRUCTION

HOUSING TYPE: MODEL T.S-11.1

DRAWING TITLE: ELEVATIONS

SCALE: NONE

DATE:

T.S.-11.1

3/8

# MODEL T.S.-11.1, TIMBER STRUCTURE

TWO STOREY

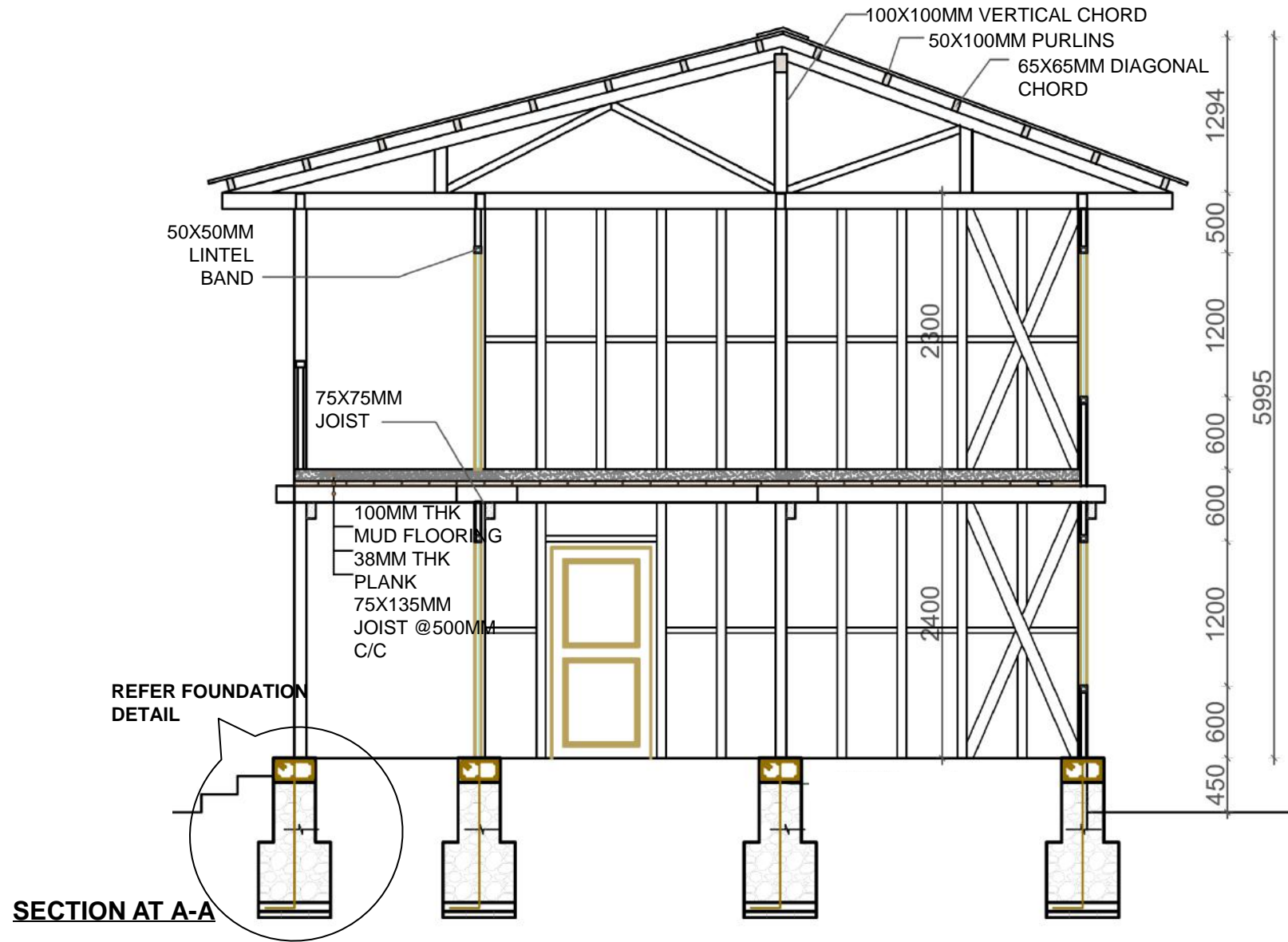

MINISTRY OF URBAN DEVELOPMENT  
 DEPARTMENT OF URBAN DEVELOPMENT AND  
 BUILDING CONSTRUCTION

HOUSING TYPE: MODEL T.S-11.1

DRAWING TITLE: SECTION

SCALE: NONE

DATE:

T.S.-11.1

4/8

# MODEL T.S.-11.1, TIMBER STRUCTURE

# TWO STOREY

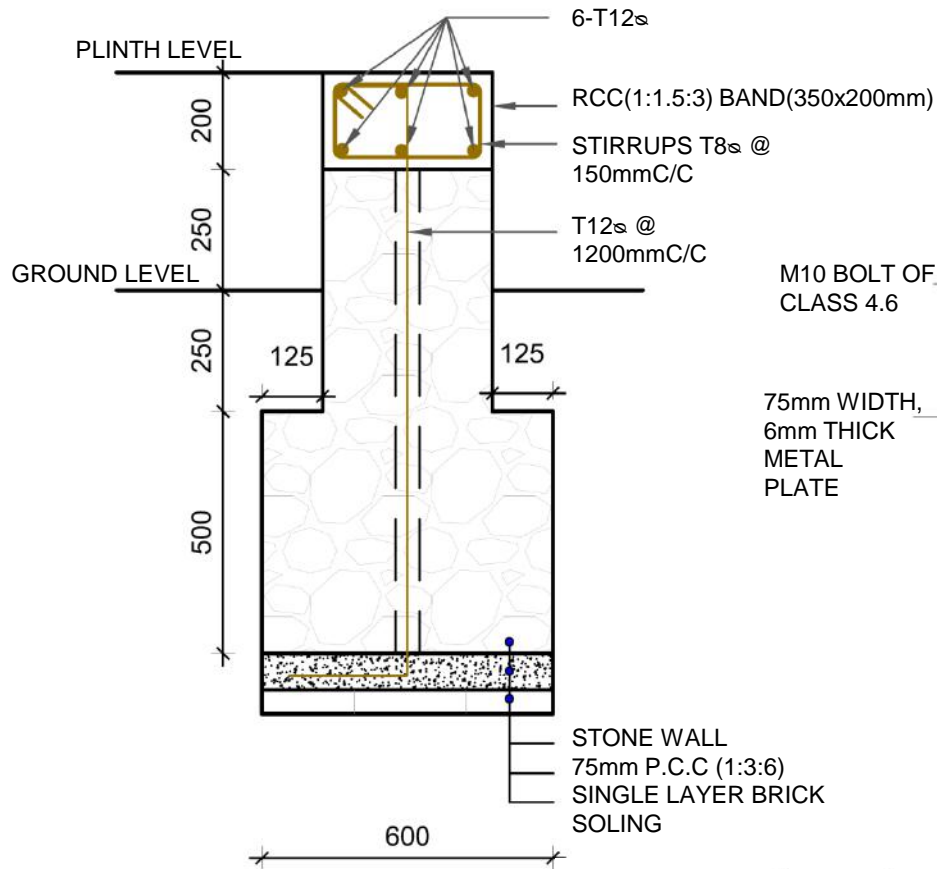

**FOUNDATION**

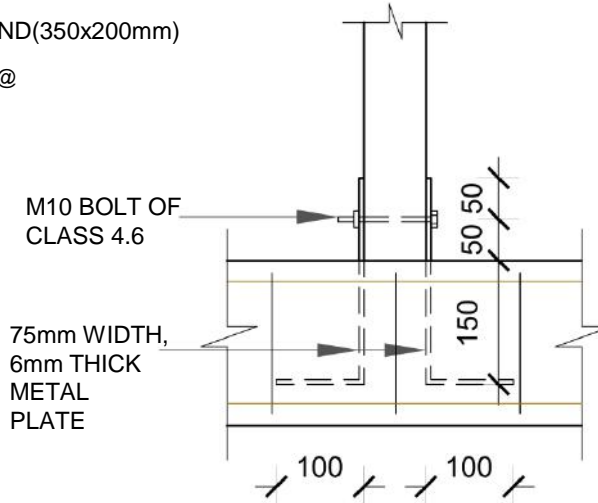
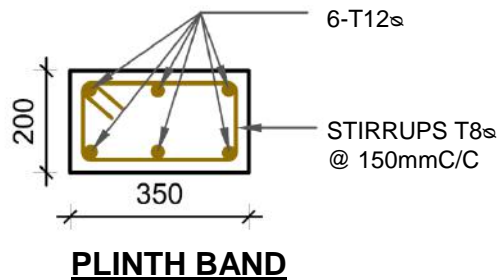

**STUD CONNECTION TO FOUNDATION OTHER THAN BRACING**

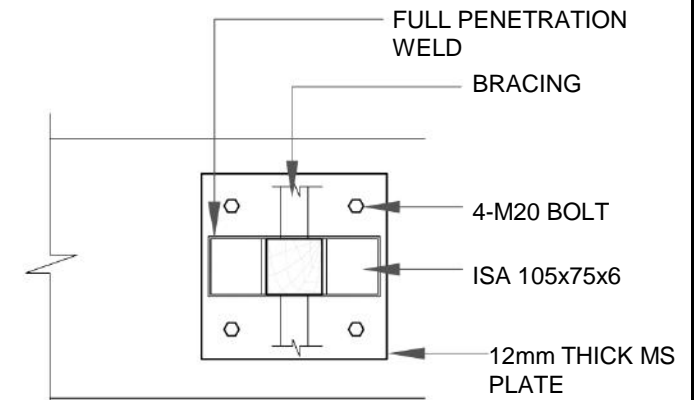

**STUD CONNECTION TO FOUNDATION AT BRACING**

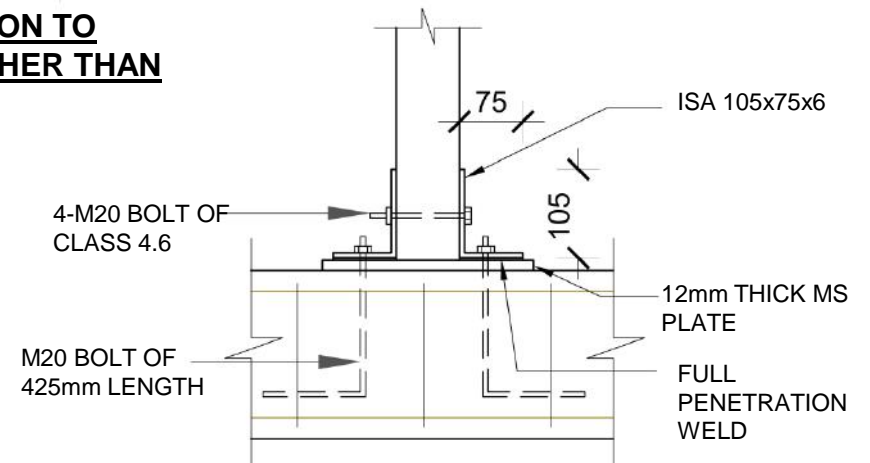

**STUD CONNECTION TO FOUNDATION AT BRACING**



MINISTRY OF URBAN DEVELOPMENT  
DEPARTMENT OF URBAN DEVELOPMENT AND  
BUILDING CONSTRUCTION

HOUSING TYPE: MODEL T.S-11.1

DRAWING TITLE: FOUNDATION DETAIL

SCALE: NONE

DATE:

T.S.-11.1

5/8





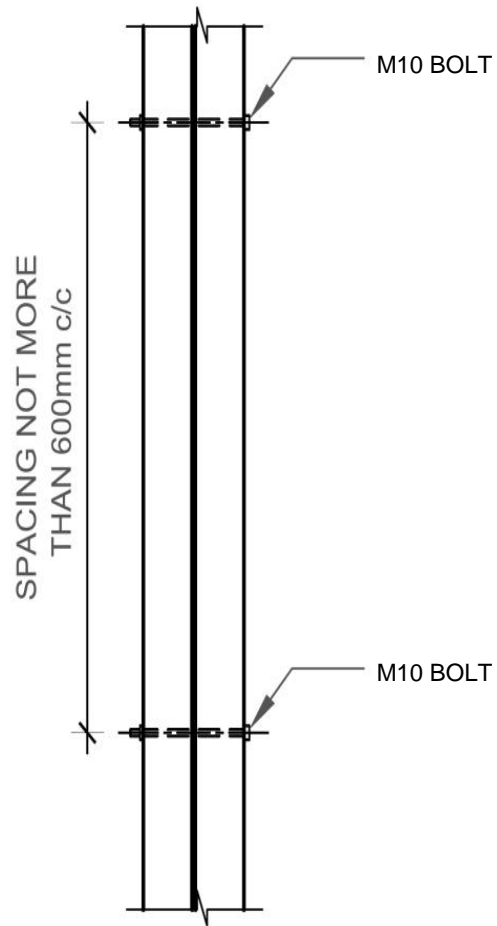

**CORNER POST CONNECTION**

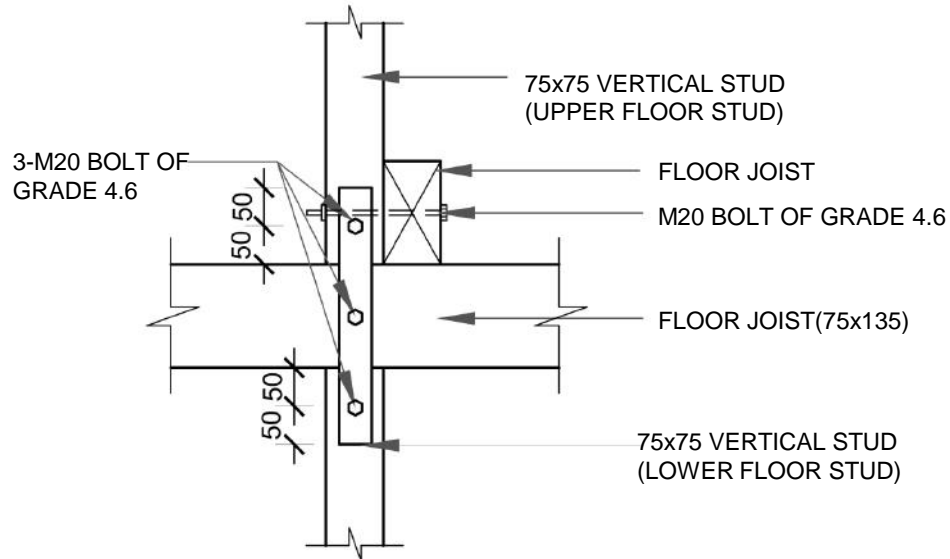

**STUD CONNECTION AT FLOOR**

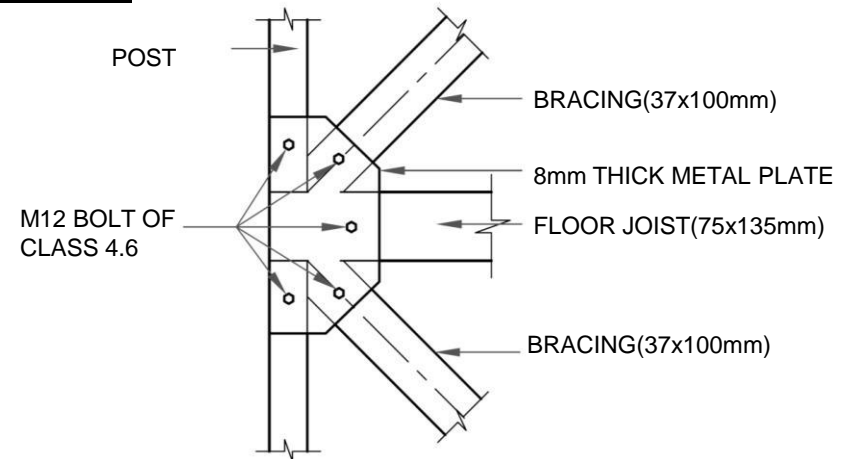

**BRACING CONNECTION**



**TECHNICAL REQUIREMENTS**

<b>Structure System</b>	Structural system consisting of timber studs (vertical members) and horizontal member load bearing System. Timber shall be hard wood like sal, khote salla or equivalent.
<b>Foundation</b>	Strip Foundation of stone masonry in 1:6 cement sand mortar and of width 600 mm width and depth 750 mm as shown in detail drawing.
<b>Plinth Band</b>	R.C.C (1:1.5:3) plinth band of size 350 x 200 mm. Main reinforcement shall be 6 nos. of 12mm dia. Bars with 8mm Ø rings at 150mm C/C.
<b>Wall System</b>	Local soft wood timber planks on timber structure system.
<b>Stud:</b>	Studs of local hard wood of size 75mm X 75 mm @500 mm C/C spacing shall be used. Connection with plinth band is shown detail drawing.
<b>Bracing:</b>	Diagonal bracing of local hard wood of size 37mm X 100mm. Connection details shown in detail drawing.
<b>Joist:</b>	Timber joist of size 75mm X 75mm with spacing of 425mm.
<b>Flooring system:</b>	Flooring shall be of mud under timber planks supported on timber joists.
<b>Roof System:</b>	Light roof steel truss covered with corrugated galvanized iron sheets. All members of the truss or joints shall be properly connected as shown in detail drawings.



# DEBRIS BLOCK MASONRY

**D.B.-12.1**

The technology proposes residence construction with block made from stone or brick debris stabilized with cement. The objective of the design is to contribute towards resilient models that helps in debris management as well as improves safety in future earthquakes.

Featured design D.B 12 is a single storied model house with 2 rooms. Bands are provided at plinth level, sill level, corner, lintel level and roof level. Roofing is of corrugated Galvanized Iron sheets under wooden rafters

### **MATERIAL PROPERTIES**

#### **For mud mortar stone masonry**

Size: 300 mm length × 150 mm width × 200 mm height

Color: light grey

Density: 2000 Kg/cm<sup>3</sup> to 2300 Kg/cm<sup>3</sup>

#### **For mud mortar brick masonry**

Size: 300 mm length × 150 mm width × 200 mm height

Color: light grey

Density: 1700 Kg/cm<sup>3</sup> to 2200 Kg/cm<sup>3</sup>

# **D.B.-12.1**



LEVEL	Debris Block	Cement	Sand	Aggregate	Reinforcing Bar	CGI Sheet	GI Sheet	Wood
	No.	Bags	Cu.m.	Cu.m.	Kg.	Bundle	Sq.m.	Cu.m.
	<b>Up to Plinth Level</b>	1,762.0	34.2	2.4	4.7	273.5		
<b>Super Structure</b>	1,923.0	21.8	1.2	2.3	307.1			0.3
<b>Roofing</b>	-	-	-	-	-	5.2	8.3	2.8
<b>TOTAL</b>	<b>3,685.0</b>	<b>56</b>	<b>3.6</b>	<b>7.0</b>	<b>580.6</b>	<b>5.2</b>	<b>8.3</b>	<b>3.1</b>



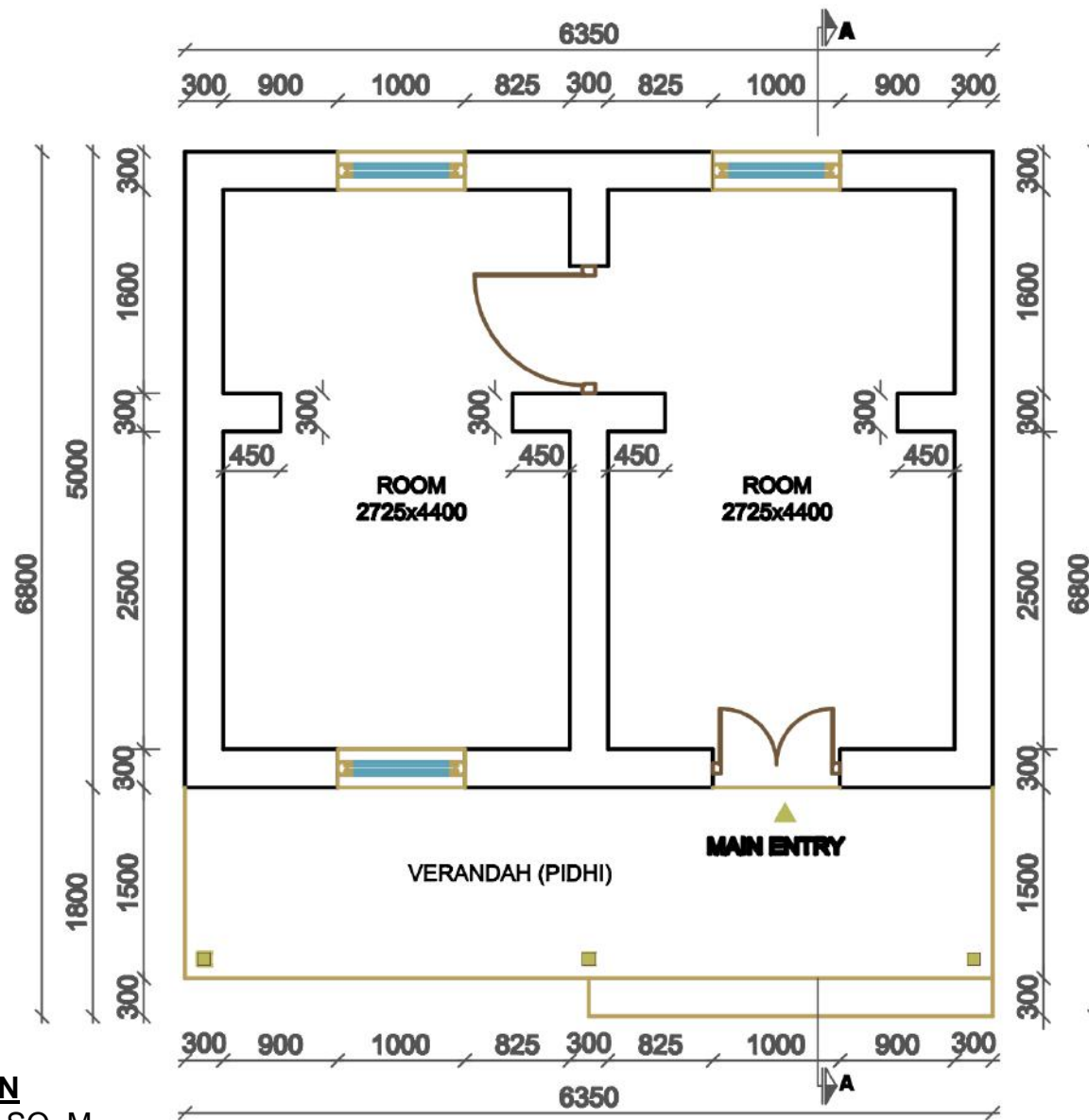

**FLOOR PLAN**  
AREA: 31.75 SQ. M.



MINISTRY OF URBAN DEVELOPMENT  
DEPARTMENT OF URBAN DEVELOPMENT AND  
BUILDING CONSTRUCTION

HOUSING TYPE: D.B.-12.1

DRAWING TITLE: FLOOR PLAN

SCALE: NONE

DATE:

D.B.-12.1

2/8

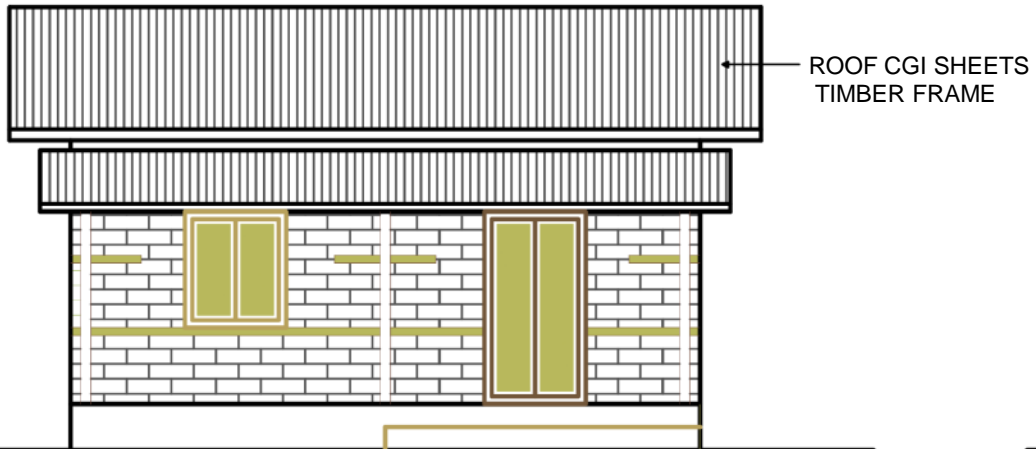

**FRONT ELEVATION**

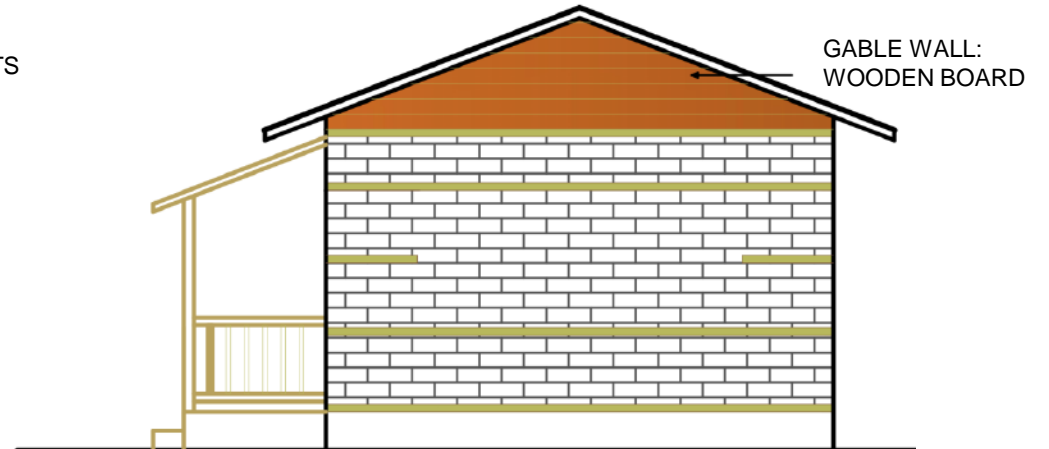

**SIDE ELEVATION**

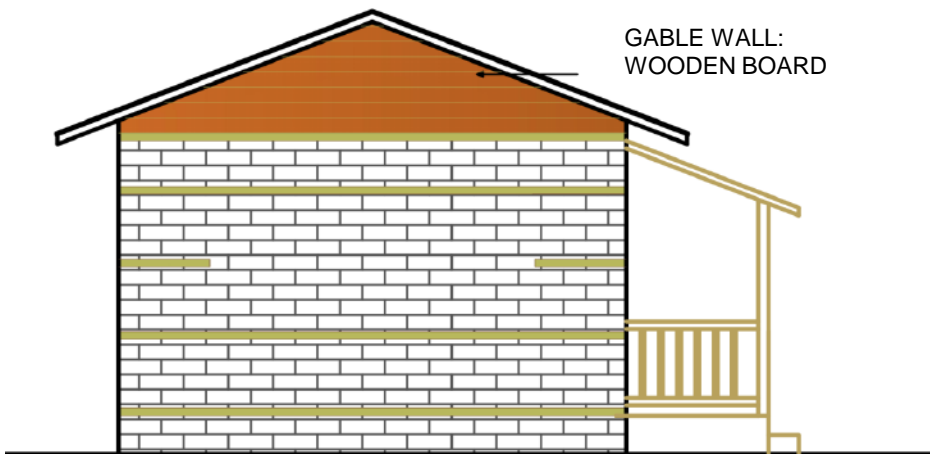

**SIDE ELEVATION**

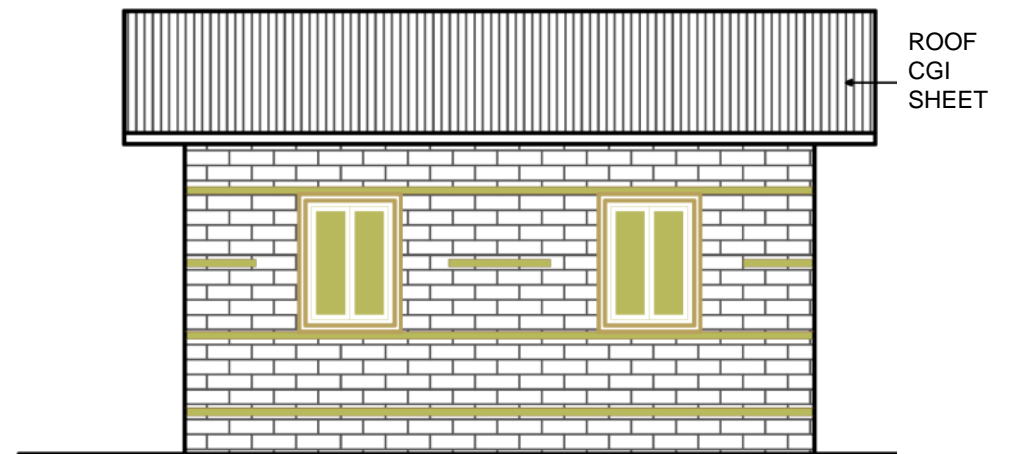

**BACK ELEVATION**



MINISTRY OF URBAN DEVELOPMENT  
DEPARTMENT OF URBAN DEVELOPMENT AND  
BUILDING CONSTRUCTION

HOUSING TYPE: D.B.-12.1

DRAWING TITLE: ELEVATIONS

SCALE: NONE

DATE:

D.B.-12.1

3/8



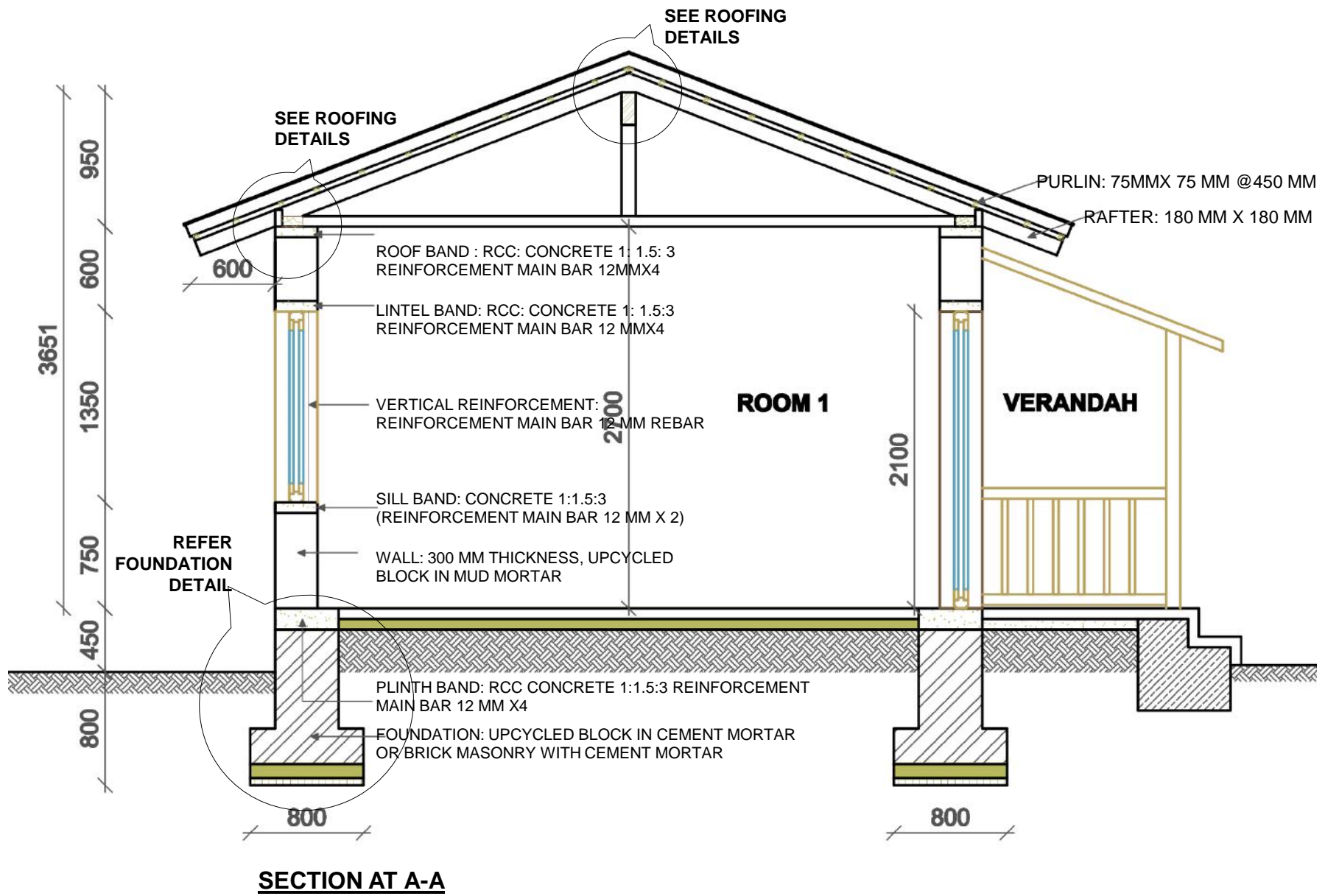

# MODEL 12.1, DEBRIS BLOCK MASONRY

ONE STOREY

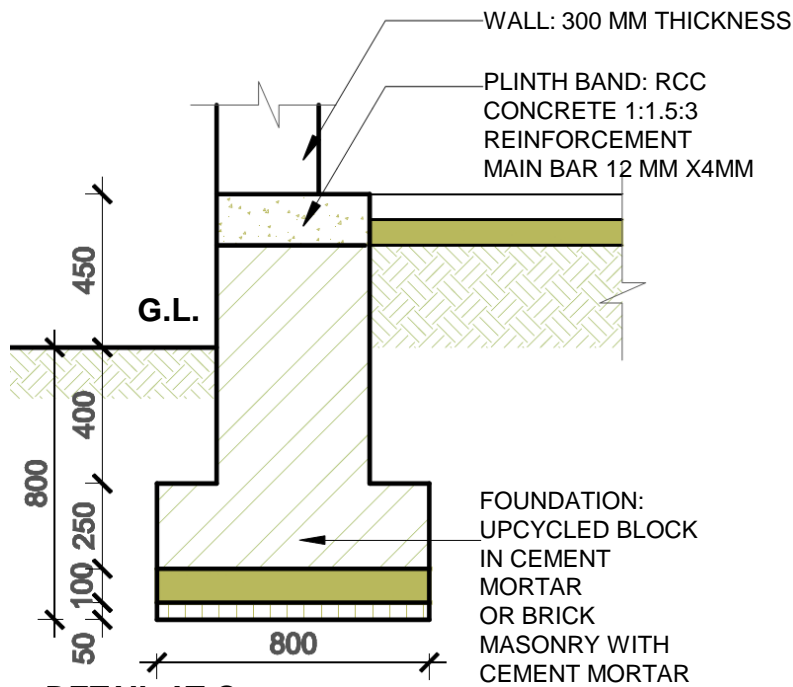

**DETAIL AT C  
FOUNDATION SECTION**

BAND/BEAM	RC BAND MIN. THICKNESS	MIN. NO. OF BAR	MIN. DIA OF BAR
PLINTH	150 MM	2	12
SILL	75 MM	2	10
LINTEL	75 MM	2	12
	150 MM	2	10 (top)
		2	12 (bottom)
ROOF	75 MM	2	12
	300 MM	4	12
DOWEL (STITCH)	75 MM	2	8

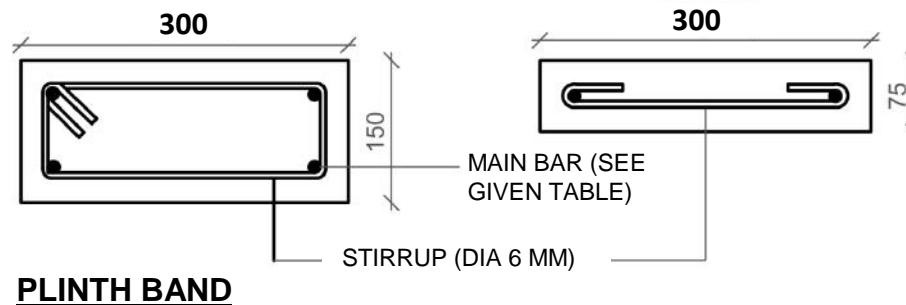

MINISTRY OF URBAN DEVELOPMENT  
DEPARTMENT OF URBAN DEVELOPMENT AND  
BUILDING CONSTRUCTION

HOUSING TYPE: D.B.-12.1

DRAWING TITLE: RCC BAND DETAIL

SCALE: NONE

DATE:

D.B.-12.1

5/8

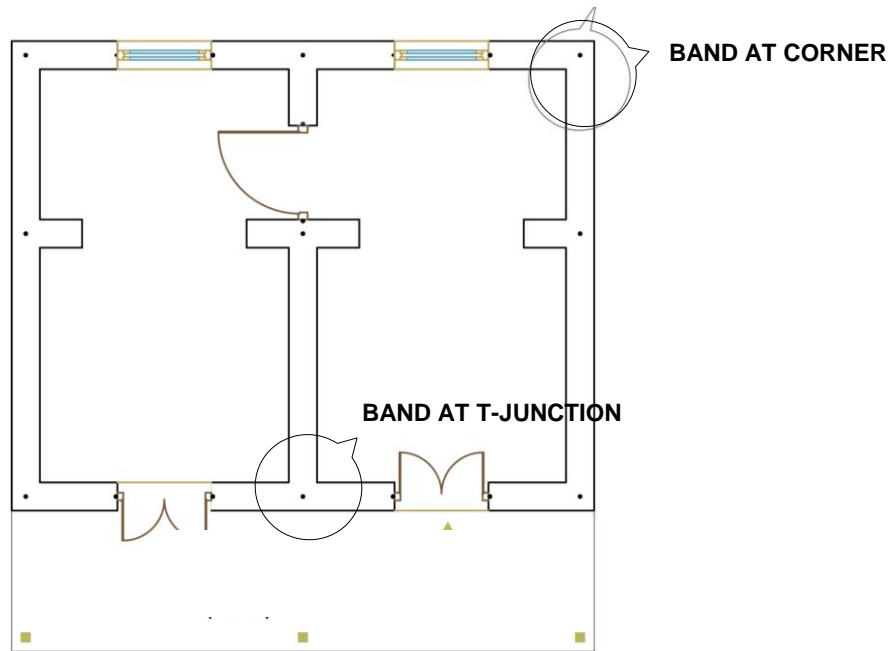

**VERTICAL REINFORCEMENT ON CORNERS & JOINTS**

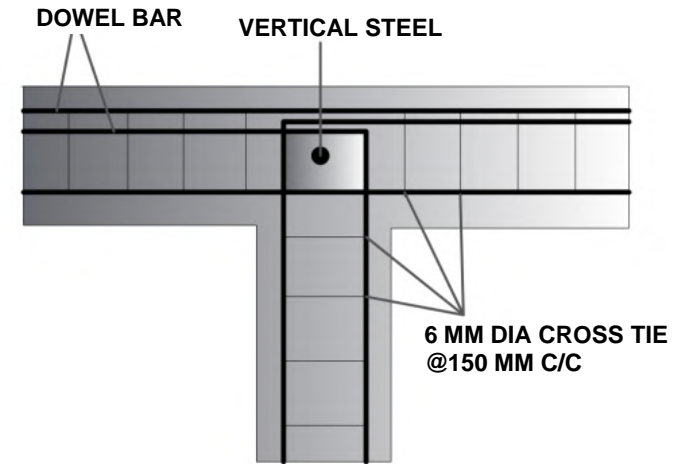

**PLAN**

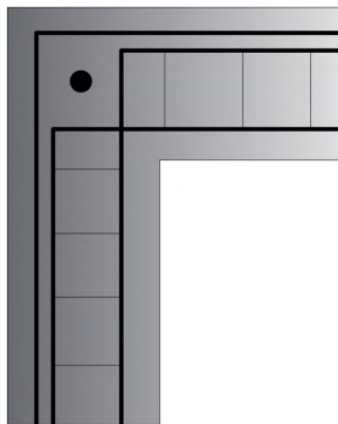

**PLAN**

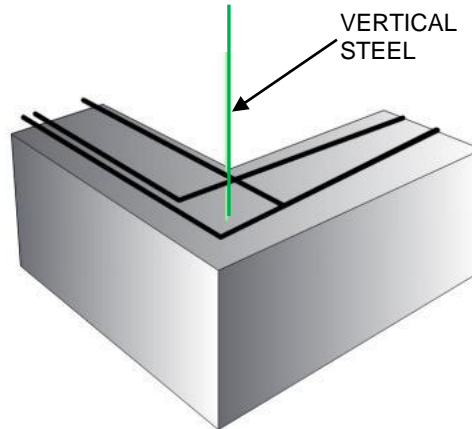

**RCC BAND AT CORNER**

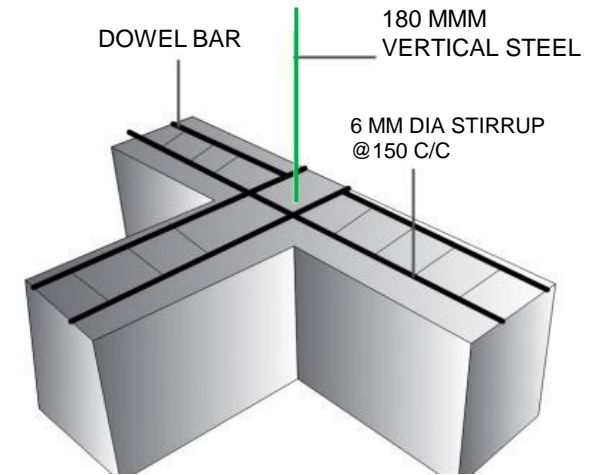

**RCC BAND AT T-JUNCTION**



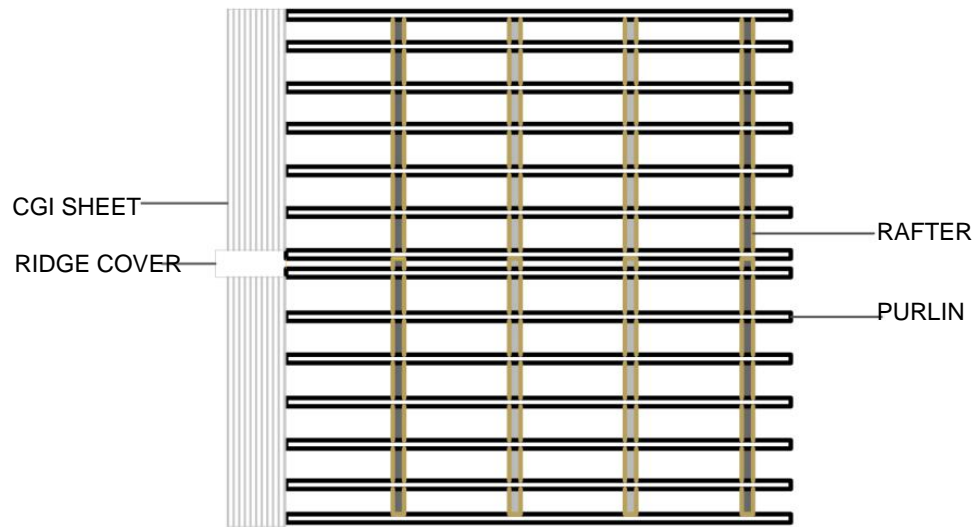

**PLAN VIEW**

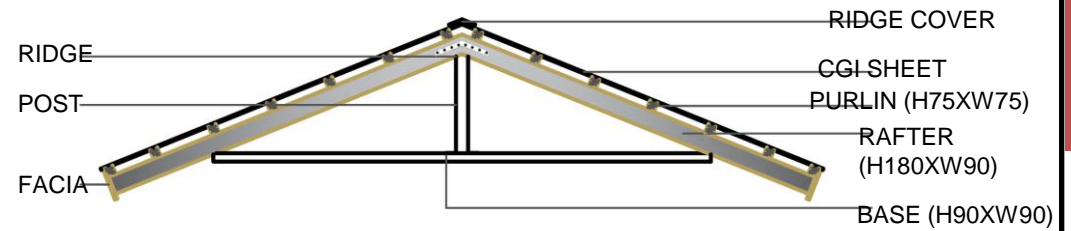

**SIDE VIEW**

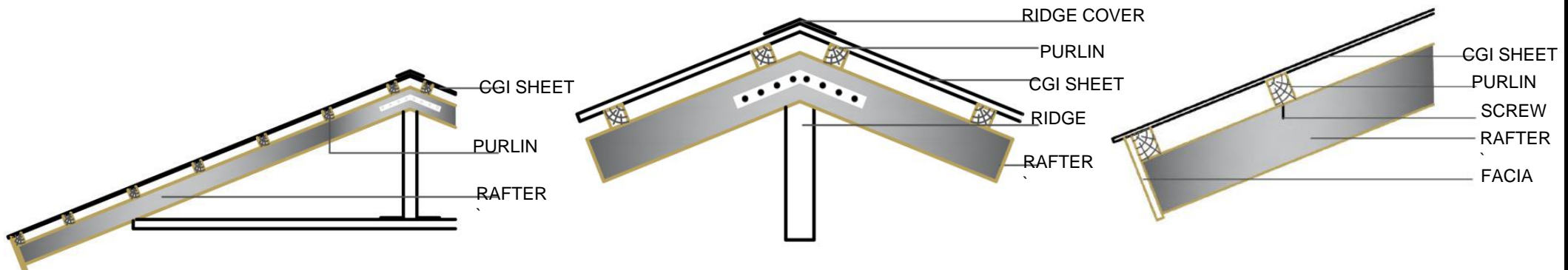

**ROOFING DETAIL**



MINISTRY OF URBAN DEVELOPMENT  
 DEPARTMENT OF URBAN DEVELOPMENT AND  
 BUILDING CONSTRUCTION

HOUSING TYPE: D.B.-12.1

DRAWING TITLE: ROOFING DETAILS

SCALE: NONE

DATE:

D.B.-12.1

7/8

**MODEL 12.1, DEBRIS BLOCK MASONRY****ONE STOREY**

<b>Structure System</b>	Load bearing stone/brick debris block masonry in mud mortar
<b>Foundation</b>	Strip Foundation with brick/ debris block masonry in mud mortar. The depth and width of foundation shall be 800mm.
<b>Plinth Band</b>	R.C.C (1:1.5:3) plinth band of size 350 x 150 mm. Main reinforcement shall be 4 nos. of 12mm dia. bars with 6mm Ø stirrups at 150mm C/C.
<b>Wall System</b>	The debris blocks used shall be of good quality and have strength as mentioned in material properties. The thickness of wall shall be greater than or equal to 300mm.
<b>Sill Band</b>	RCC (1:1.5:3) sill band shall be provided throughout the entire wall at the bottom level of the openings. The minimum depth of the band shall be 75mm. Main reinforcement shall be 2 nos.12mm dia. bars with 6 mm Ø stirrups at 150mm C/C.
<b>Lintel Band:</b>	RCC (1:1.5:3) lintel band shall be provided throughout the entire wall at the top level of the openings. The minimum depth of the band shall be 75mm. Main reinforcement shall be 2nos.12mm dia. bars with 6mm Ø stirrups at 150mm C/C or as specified in the details.
<b>Roof Band:</b>	RCC (1:1.5:3) roof band shall be provided throughout the entire wall at roof level. The minimum depth of the band shall be 75mm. Main reinforcement shall be 2 nos. 12mm dia. bars with 6mm Ø stirrups at 150mm C/C.
<b>Roof System:</b>	Light roof timber truss with CGI sheet roofing. All members of the truss or joints shall be properly connected as shown in detail drawings.



MINISTRY OF URBAN DEVELOPMENT  
DEPARTMENT OF URBAN DEVELOPMENT AND  
BUILDING CONSTRUCTION

HOUSING TYPE: D.B.-12.1

SCALE: NONE

D.B.-12.1

DRAWING TITLE: TECHNICAL DETAILS

DATE:

8/8

## **PERSONNEL INVOLVED IN PREPARATION OF THIS CATALOGUE**

### **DUDBC (HOUSING DIVISION)**

D.D.G. RAM CHANDRA DANGAL  
ER. RABI SHAH (FORMER D.D.G.)  
S.D.E. HIMAL K.C  
S.D.E. PRATIGYA MANANDAR  
S.D.E. RAJU NEUPANE  
AR. JEETA GURUNG  
SUB-ER. PURNA RAJTHALA  
COM. OP. RAM KRISHNA KHATRI

### **STRUCTURAL EXPERT**

PROF. DR. PREM NATH MASKEY  
DR. PURUSHOTTAM DONGOL

### **TECHNICAL WORKING GROUPS**

S.D.E. MACHAKAJI MAHARJAN  
S.D.E. MANOJ NAKARMI  
S.D.E. GANESH KARMACHARYA  
ER. SURENDRA VAIDYA  
ER. DEVENDRA DEV KHANAL  
ER. PRATIK PRADHAN

### **CLPIU**

S.D.E. PARIKSHIT KADARIYA (DEPUTY PROJECT DIRECTOR)  
ER. BIPIN KUMAR GAUTAM  
ER. MANOJ KUMAR BISTA  
ER. MINESH RATNA TAMRAKAR  
ER. NIYAM MAHARJAN  
ER. DIPENDRA ARYAL  
AR. KRISHNA LAXMI MAHARJAN  
AR. KOPILA WAGLE  
AR. POOJA SHAH  
AR. PRABINA POKHAREL  
AR. SMRITI UPADHYAY  
AR. SHAMI ADHIKARI

## **AGENCIES/ PERSONNEL SUBMITTING PROPOSAL**

**AR. ASHISH SHARAN LAL  
NATIONAL CENTRE FOR PEOPLE'S ACTION IN DISASTER PREPAREDNESS (NCPDP-INDIA) / UNITED NATION DEVELOPMENT  
PROGRAM (UNDP-NEPAL)  
ASIAN INSTITUTE OF TECHNOLOGY (AIT)  
BUILDCHANGE/ MERCYCORPS  
ABARI NEPAL  
MINERGY INITIATIVES  
RANDOLPH LANGENBACH  
SAMARACHANA NEPAL  
ER. SHANKAR DHAKAL  
CENTRAL OFFICE RE-ARCHITECTED AS A DATACENTER (CORD)  
GOOD EARTH NEPAL  
HABITAT FOR HUMANITY  
PORTAL PREFAB  
PI ENGINEERING  
PANCHAKANYA GROUP  
GO GREEN ENGINEERING  
BUILDERS WITHOUT BORDERS  
SHELTER AND LOCAL TECHNOLOGY DEVELOPMENT CENTER (SLTDC)  
AAC ITTA UDHYOG PVT. LTD.  
JAPAN INTERNATIONAL COOPERATION AGENCY (JICA)  
INTERNATIONAL GREEN DEVELOPERS  
FUTURE WORKS  
SEISMIC NEPAL  
ARCHITECTURE AND DEVELOPMENT  
BUILT UP NEPAL  
UNITED NATION DEVELOPMENT PROGRAM (UNDP)  
THE FAMILY OF MARTYRS SOCIETY  
CREATIVE SERVICES PRIVATE LTD.  
SUPER ECO-BRICK INNOVATIONS  
INNO-TECH NEPAL PVT LTD.  
STEADFAST COMPANIES**